



# SGM4574

## 4-Bit Bidirectional Voltage-Level Translator for Open-Drain and Push-Pull Applications

### GENERAL DESCRIPTION

This 4-bit non-inverting translator uses two separate configurable power-supply rails. The A ports are designed to track  $V_{CCA}$ .  $V_{CCA}$  accepts any supply voltage from 1.65V to 5.5V.  $V_{CCA}$  must be less than or equal to  $V_{CCB}$ . The B ports are designed to track  $V_{CCB}$ .  $V_{CCB}$  accepts any supply voltage from 2.3V to 5.5V. This allows for low-voltage bidirectional translation between any of the 1.8V, 2.5V, 3.3V, and 5V voltage nodes.

When the output-enable (OE) input is low, all I/Os are placed in the high-impedance state.

The SGM4574 is designed so that the OE input circuit is supplied by  $V_{CCA}$ .

To ensure the high-impedance state during power-up or power-down, OE should be tied to GND through a pull-down resistor; the minimum value of the resistor is determined by the current-sourcing capability of the driver.

The SGM4574 is available in Green SOIC-14, UTQFN-1.8×1.8-12L and TQFN-2×2-12L packages. It operates over an ambient temperature range of -40°C to +85°C.

### TYPICAL APPLICATION

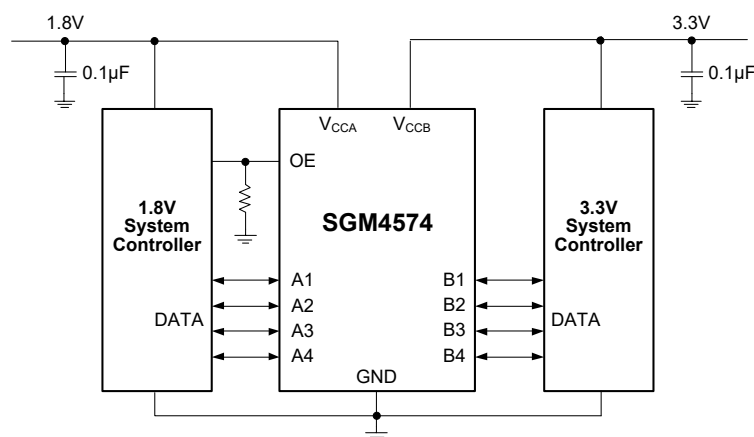

Figure 1. Typical Application Circuit

### FEATURES

- No Direction-Control Signal Needed
- Data Rates
  - 24Mbps (Push-Pull)
  - 2Mbps (Open-Drain)
- 1.65V to 5.5V on A ports and 2.3V to 5.5V on B ports ( $V_{CCA} \leq V_{CCB}$ )
- No Power-Supply Sequencing Required
  - Either  $V_{CCA}$  or  $V_{CCB}$  Can Be Ramped First
- Available in Green SOIC-14, UTQFN-1.8×1.8-12L and TQFN-2×2-12L Packages

### APPLICATIONS

Handset  
Smartphone  
Tablet  
Desktop PC

**PACKAGE/ORDERING INFORMATION**

MODEL	PACKAGE DESCRIPTION	SPECIFIED TEMPERATURE RANGE	ORDERING NUMBER	PACKAGE MARKING	PACKING OPTION
SGM4574	TQFN-2x2-12L	-40°C to +85°C	SGM4574YTQM12G/TR	4574 XXXX	Tape and Reel, 3000
	SOIC-14	-40°C to +85°C	SGM4574YS14G/TR	SGM4574YS14 XXXXX	Tape and Reel, 2500
	UTQFN-1.8x1.8-12L	-40°C to +85°C	SGM4574YUQN12G/TR	4574 XXXX	Tape and Reel, 3000

NOTE: XXXX = Date Code. XXXXX = Date Code and Vendor Code.

Green (RoHS & HSF): SG Micro Corp defines "Green" to mean Pb-Free (RoHS compatible) and free of halogen substances. If you have additional comments or questions, please contact your SGMICRO representative directly.

**OVERSTRESS CAUTION**

Stresses beyond those listed may cause permanent damage to the device. Functional operation of the device at these or any other conditions beyond those indicated in the operational section of the specification is not implied. Exposure to absolute maximum rating conditions for extended periods may affect reliability.

**DISCLAIMER**

SG Micro Corp reserves the right to make any change in circuit design, specification or other related things if necessary without notice at any time.

**ESD SENSITIVITY CAUTION**

This integrated circuit can be damaged by ESD if you don't pay attention to ESD protection. SGMICRO recommends that all integrated circuits be handled with appropriate precautions. Failure to observe proper handling and installation procedures can cause damage. ESD damage can range from subtle performance degradation to complete device failure. Precision integrated circuits may be more susceptible to damage because very small parametric changes could cause the device not to meet its published specifications.

**ABSOLUTE MAXIMUM RATINGS**

Supply Voltage Range

$V_{CCA}$  ..... -0.3V to 6V

$V_{CCB}$  ..... -0.3V to 6V

A Ports, B Ports, OE Input Voltage Range,  $V_I$  <sup>(1)</sup>  
..... -0.3V to 6V

Voltage Range Applied to Any Output in the High-Impedance  
or Power-Off State,  $V_O$  <sup>(1)</sup>

A Ports ..... -0.3V to 6V

B Ports ..... -0.3V to 6V

Voltage Range Applied to Any Output in the High or Low  
State,  $V_O$  <sup>(1)(2)</sup>

A Ports ..... -0.3V to  $V_{CCA} + 0.3V$

B Ports ..... -0.3V to  $V_{CCB} + 0.3V$

Input Clamp Current,  $I_{IK}$  ( $V_I < 0$ ) ..... -50mA

Output Clamp Current,  $I_{OK}$  ( $V_O < 0$ ) ..... -25mA

Continuous Output Current,  $I_O$  .....  $\pm 50mA$

Continuous Current through  $V_{CCA}$ ,  $V_{CCB}$ , or GND .....  $\pm 100mA$

Junction Temperature ..... +150°C

Storage Temperature Range ..... -65°C to +150°C

Lead Temperature (Soldering, 10s) ..... +260°C

**NOTES:**

1. The input and output negative-voltage ratings may be exceeded if the input and output current ratings are observed.
2. The value of  $V_{CCA}$  and  $V_{CCB}$  are provided in the recommended operating conditions table.

**RECOMMENDED OPERATING CONDITIONS**  
(3, 4)

Supply Voltage Range <sup>(5)</sup>

$V_{CCA}$  ..... 1.65V to 5.5V

$V_{CCB}$  ..... 2.3V to 5.5V

High-Level Input Voltage,  $V_{IH}$

A Port I/Os ( $V_{CCA} = 1.65V$  to  $1.95V$ ,  $V_{CCB} = 2.3V$  to  $5.5V$ )  
.....  $V_{CCI} - 0.1V$  to  $V_{CCI}$

A Port I/Os ( $V_{CCA} = 2.3V$  to  $5.5V$ ,  $V_{CCB} = 2.3V$  to  $5.5V$ )  
.....  $V_{CCI} - 0.3V$  to  $V_{CCI}$

B Port I/Os ( $V_{CCA} = 1.65V$  to  $5.5V$ ,  $V_{CCB} = 2.3V$  to  $5.5V$ )  
.....  $V_{CCI} - 0.3V$  to  $V_{CCI}$

OE Input ( $V_{CCA} = 1.65V$  to  $5.5V$ ,  $V_{CCB} = 2.3V$  to  $5.5V$ )  
.....  $V_{CCA} \times 0.8V$  to  $5.5V$

Low-Level Input Voltage,  $V_{IL}$

A Port I/Os ( $V_{CCA} = 1.65V$  to  $5.5V$ ,  $V_{CCB} = 2.3V$  to  $5.5V$ )  
..... 0V to 0.1V

B Port I/Os ( $V_{CCA} = 1.65V$  to  $5.5V$ ,  $V_{CCB} = 2.3V$  to  $5.5V$ )  
..... 0V to 0.1V

OE Input ( $V_{CCA} = 1.65V$  to  $5.5V$ ,  $V_{CCB} = 2.3V$  to  $5.5V$ )  
..... 0V to  $V_{CCA} \times 0.2V$

Operating Temperature Range ..... -40°C to +85°C

**NOTES:**

3.  $V_{CCI}$  is the  $V_{CC}$  associated with the input ports.
4.  $V_{CCO}$  is the  $V_{CC}$  associated with the output ports.
5.  $V_{CCA}$  must be less than or equal to  $V_{CCB}$ , and  $V_{CCA}$  must not exceed 5.5V.

PIN CONFIGURATIONS

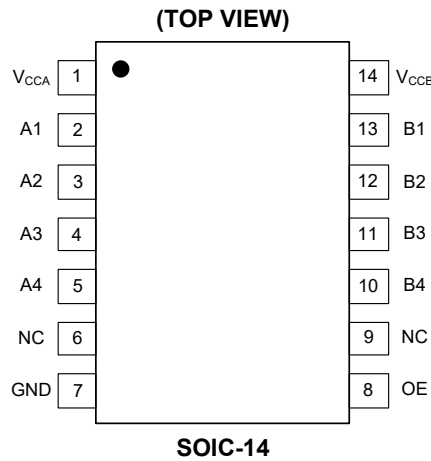
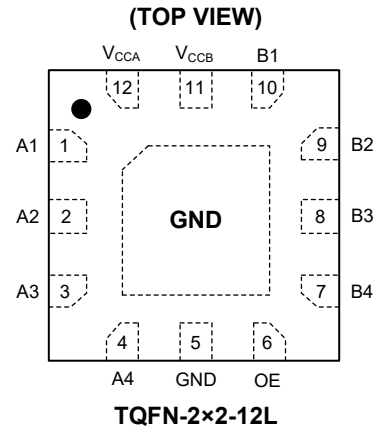
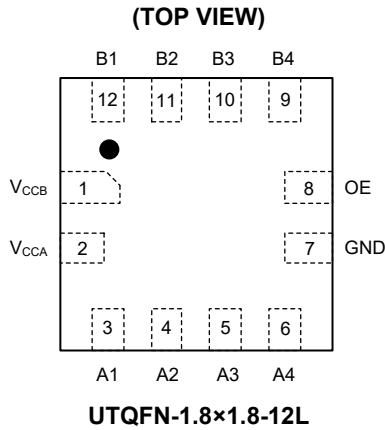

PIN DESCRIPTION

PIN			NAME	TYPE	FUNCTION
TQFN-2x2-12L	UTQFN-1.8x1.8-12L	SOIC-14			
1	3	2	A1	I/O	Input/Output A1. Referenced to V <sub>CCA</sub> .
2	4	3	A2	I/O	Input/Output A2. Referenced to V <sub>CCA</sub> .
3	5	4	A3	I/O	Input/Output A3. Referenced to V <sub>CCA</sub> .
4	6	5	A4	I/O	Input/Output A4. Referenced to V <sub>CCA</sub> .
–	–	6, 9	NC	–	No Connection. Not internally connected.
5	7	7	GND	S	Ground
6	8	8	OE	I	3-State Output-Mode Enable. Pull OE low to place all outputs in 3-state mode. Referenced to V <sub>CCA</sub> .
7	9	10	B4	I/O	Input/Output B4. Referenced to V <sub>CCB</sub> .
8	10	11	B3	I/O	Input/Output B3. Referenced to V <sub>CCB</sub> .
9	11	12	B2	I/O	Input/Output B2. Referenced to V <sub>CCB</sub> .
10	12	13	B1	I/O	Input/Output B1. Referenced to V <sub>CCB</sub> .
11	1	14	V <sub>CCB</sub>	S	B Ports Supply Voltage. 2.3V ≤ V <sub>CCB</sub> ≤ 5.5V.
12	2	1	V <sub>CCA</sub>	S	A Ports Supply Voltage. 1.65V ≤ V <sub>CCA</sub> ≤ 5.5V and V <sub>CCA</sub> ≤ V <sub>CCB</sub> .
Exposed Pad	–	–	GND	–	Exposed pad should be soldered to PCB board and connected to GND or left floating.

## ELECTRICAL CHARACTERISTICS

( $V_{CCA} = 1.65V$  to  $5.5V$ ,  $V_{CCB} = 2.3V$  to  $5.5V$ , typical values are at  $T_A = +25^\circ C$ , unless otherwise noted.)

PARAMETER		CONDITIONS		MIN	TYP	MAX	UNITS
A Ports High Level Output Voltage ( $V_{OHA}$ )		$I_{OH} = -20\mu A$ , $V_{IB} \geq V_{CCB} - 0.4V$			$V_{CCA} \times 0.8$		V
A Ports Low Level Output Voltage ( $V_{OLA}$ )		$I_{OL} = 1mA$ , $V_{IB} \leq 0.15V$			0.2		
B Ports High Level Output Voltage ( $V_{OHB}$ )		$I_{OH} = -20\mu A$ , $V_{IA} \geq V_{CCA} - 0.4V$			$V_{CCB} \times 0.8$		
B Ports Low Level Output Voltage ( $V_{OLB}$ )		$I_{OL} = 1mA$ , $V_{IA} \leq 0.15V$			0.2		
Input Leakage Current ( $I_I$ )	OE				0.5		$\mu A$
Power Off Leakage Current ( $I_{OFF}$ )	A Ports	$V_{CCA} = 0V$ , $V_{CCB} = 0V$ to $5.5V$			0.1		$\mu A$
	B Ports	$V_{CCA} = 0V$ to $5.5V$ , $V_{CCB} = 0V$			0.1		
3-State Output Leakage ( $I_{OZ}$ )	A or B Ports	OE = 0V			0.1		$\mu A$
Quiescent Supply Current ( $I_{CCA}$ )	$V_I = V_O = OPEN$ , $I_O = 0$	$V_{CCA} = 1.65V$ to $V_{CCB}$ , $V_{CCB} = 2.3V$ to $5.5V$			0.1		$\mu A$
		$V_{CCA} = 5.5V$ , $V_{CCB} = 0V$			0.1		
		$V_{CCA} = 0V$ , $V_{CCB} = 5.5V$			0.1		
Quiescent Supply Current ( $I_{CCB}$ )	$V_I = V_O = OPEN$ , $I_O = 0$	$V_{CCA} = 1.65V$ to $V_{CCB}$ , $V_{CCB} = 2.3V$ to $5.5V$			7		$\mu A$
		$V_{CCA} = 5.5V$ , $V_{CCB} = 0V$			0.1		
		$V_{CCA} = 0V$ , $V_{CCB} = 5.5V$			0.1		
Quiescent Supply Current ( $I_{CCA} + I_{CCB}$ )	$V_I = V_O = OPEN$ , $I_O = 0$	$V_{CCA} = 1.65V$ to $V_{CCB}$ , $V_{CCB} = 2.3V$ to $5.5V$			7.1		$\mu A$
Quiescent Supply Current ( $I_{CCZA}$ )	$V_I = V_{CCI}$ or $0V$ , $I_O = 0$ , OE = 0V	$V_{CCA} = 1.65V$ to $V_{CCB}$ , $V_{CCB} = 2.3V$ to $5.5V$			0.1		$\mu A$
		$V_{CCA} = 5.5V$ , $V_{CCB} = 0V$			0.1		
		$V_{CCA} = 0V$ , $V_{CCB} = 5.5V$			0.1		
Quiescent Supply Current ( $I_{CCZB}$ )	$V_I = V_{CCI}$ or $0V$ , $I_O = 0$ , OE = 0V	$V_{CCA} = 1.65V$ to $V_{CCB}$ , $V_{CCB} = 2.3V$ to $5.5V$			0.1		$\mu A$
		$V_{CCA} = 5.5V$ , $V_{CCB} = 0V$			0.1		
		$V_{CCA} = 0V$ , $V_{CCB} = 5.5V$			0.1		
OE Input Capacitance ( $C_i$ )	$V_{CCA} = 3.3V$ , $V_{CCB} = 3.3V$			6.4		pF	
Input/Output Capacitance A Ports ( $C_{IO}$ )	$V_{CCA} = 3.3V$ , $V_{CCB} = 3.3V$			6.3		pF	
Input/Output Capacitance B Ports ( $C_{IO}$ )				6.4			

## TIMING REQUIREMENTS

PARAMETER		V <sub>CCB</sub> = 2.5V	V <sub>CCB</sub> = 3.3V	V <sub>CCB</sub> = 5V	UNITS	
		TYP	TYP	TYP		
<b>(T<sub>A</sub> = +25°C, V<sub>CCA</sub> = 1.8V, unless otherwise noted.)</b>						
Data Rate	Push-Pull Driving		24	24	24	Mbps
	Open-Drain Driving		2	2	2	
Pulse Duration (t <sub>w</sub> )	Push-Pull Driving	Data Inputs	41	41	41	ns
	Open-Drain Driving		500	500	500	
<b>(T<sub>A</sub> = +25°C, V<sub>CCA</sub> = 2.5V, unless otherwise noted.)</b>						
Data Rate	Push-Pull Driving		24	24	24	Mbps
	Open-Drain Driving		2	2	2	
Pulse Duration (t <sub>w</sub> )	Push-Pull Driving	Data Inputs	41	41	41	ns
	Open-Drain Driving		500	500	500	
<b>(T<sub>A</sub> = +25°C, V<sub>CCA</sub> = 3.3V, unless otherwise noted.)</b>						
Data Rate	Push-Pull Driving			24	24	Mbps
	Open-Drain Driving			2	2	
Pulse Duration (t <sub>w</sub> )	Push-Pull Driving	Data Inputs		41	41	ns
	Open-Drain Driving			500	500	
<b>(T<sub>A</sub> = +25°C, V<sub>CCA</sub> = 5V, unless otherwise noted.)</b>						
Data Rate	Push-Pull Driving				24	Mbps
	Open-Drain Driving				2	
Pulse Duration (t <sub>w</sub> )	Push-Pull Driving	Data Inputs			41	ns
	Open-Drain Driving				500	

## SWITCHING CHARACTERISTICS

(T<sub>A</sub> = +25°C, V<sub>CCA</sub> = 1.8V, unless otherwise noted. )

PARAMETER	FROM (INPUT)	TO (OUTPUT)	TEST CONDITIONS	V <sub>CCB</sub> = 2.5V	V <sub>CCB</sub> = 3.3V	V <sub>CCB</sub> = 5V	UNITS
				TYP	TYP	TYP	
t <sub>PHL</sub>	A	B	Push-Pull Driving	3.5	3.5	5.1	ns
			Open-Drain Driving	56.2	27.0	27.9	
t <sub>PLH</sub>			Push-Pull Driving	5.1	4.5	4.4	
			Open-Drain Driving	143	120	92	
t <sub>PHL</sub>	B	A	Push-Pull Driving	3.0	2.8	3.4	ns
			Open-Drain Driving	25.6	25.3	25.4	
t <sub>PLH</sub>			Push-Pull Driving	3.7	3.2	2.6	
			Open-Drain Driving	55	49	48	
t <sub>EN</sub> (t <sub>PZH</sub> & t <sub>PZL</sub> )	OE	A or B		28	25	23	ns
t <sub>DIS</sub> (t <sub>PHZ</sub> & t <sub>PLZ</sub> )	OE	A or B		674	677	671	ns
t <sub>rA</sub>	A Ports Rise Time		Push-Pull Driving	7.2	8.1	9.1	ns
			Open-Drain Driving	12	11	10	
t <sub>rB</sub>	B Ports Rise Time		Push-Pull Driving	7.2	6.1	5.4	ns
			Open-Drain Driving	99	73	37	
t <sub>fA</sub>	A Ports Fall Time		Push-Pull Driving	5.7	5.9	6.9	ns
			Open-Drain Driving	3.8	3.6	3.6	
t <sub>fB</sub>	B Ports Fall Time		Push-Pull Driving	7.9	7.8	8.4	ns
			Open-Drain Driving	3.5	8.4	5.0	
Data Rate			Push-Pull Driving	24	24	24	Mbps
			Open-Drain Driving	2	2	2	

## SWITCHING CHARACTERISTICS (continued)

(T<sub>A</sub> = +25°C, V<sub>CCA</sub> = 2.5V, unless otherwise noted. )

PARAMETER	FROM (INPUT)	TO (OUTPUT)	TEST CONDITIONS	V <sub>CCB</sub> = 2.5V	V <sub>CCB</sub> = 3.3V	V <sub>CCB</sub> = 5V	UNITS
				TYP	TYP	TYP	
t <sub>PHL</sub>	A	B	Push-Pull Driving	4.5	4.5	5.0	ns
			Open-Drain Driving	26.2	27.1	26.2	
t <sub>PLH</sub>			Push-Pull Driving	3.8	3.3	3.1	
			Open-Drain Driving	111	96	76	
t <sub>PHL</sub>	B	A	Push-Pull Driving	4.2	4.0	4.1	ns
			Open-Drain Driving	25.8	25.5	25.6	
t <sub>PLH</sub>			Push-Pull Driving	3.7	3.5	3.6	
			Open-Drain Driving	53	51	50	
t <sub>EN</sub> (t <sub>PZH</sub> & t <sub>PZL</sub> )	OE	A or B		22	17	16	ns
t <sub>DIS</sub> (t <sub>PHZ</sub> & t <sub>PLZ</sub> )	OE	A or B		689	688	678	ns
t <sub>rA</sub>	A Ports Rise Time		Push-Pull Driving	6.4	6.7	6.9	ns
			Open-Drain Driving	10.5	7.7	7.8	
t <sub>rB</sub>	B Ports Rise Time		Push-Pull Driving	6.2	5.4	4.9	ns
			Open-Drain Driving	67	51	30	
t <sub>fA</sub>	A Ports Fall Time		Push-Pull Driving	8.6	8.2	7.3	ns
			Open-Drain Driving	3.6	3.3	3.1	
t <sub>fB</sub>	B Ports Fall Time		Push-Pull Driving	8.5	7.7	8.1	ns
			Open-Drain Driving	3.4	3.9	5.4	
Data Rate			Push-Pull Driving	24	24	24	Mbps
			Open-Drain Driving	2	2	2	

## SWITCHING CHARACTERISTICS (continued)

(T<sub>A</sub> = +25°C, V<sub>CCA</sub> = 3.3V, unless otherwise noted. )

PARAMETER	FROM (INPUT)	TO (OUTPUT)	TEST CONDITIONS	V <sub>CCB</sub> = 3.3V	V <sub>CCB</sub> = 5V	UNITS
				TYP	TYP	
t <sub>PHL</sub>	A	B	Push-Pull Driving	4.4	5.0	ns
			Open-Drain Driving	25.5	27.5	
t <sub>PLH</sub>			Push-Pull Driving	3.5	2.7	
			Open-Drain Driving	52	51	
t <sub>PHL</sub>	B	A	Push-Pull Driving	4.1	4.4	ns
			Open-Drain Driving	25.8	54.3	
t <sub>PLH</sub>			Push-Pull Driving	3.1	2.8	
			Open-Drain Driving	50	49	
t <sub>EN</sub> (t <sub>PZH</sub> & t <sub>PZL</sub> )	OE	A or B		16	14	ns
t <sub>DIS</sub> (t <sub>PHZ</sub> & t <sub>PLZ</sub> )	OE	A or B		699	678	
t <sub>rA</sub>	A Ports Rise Time		Push-Pull Driving	5.2	6.2	ns
			Open-Drain Driving	6	6	
t <sub>rB</sub>	B Ports Rise Time		Push-Pull Driving	5.3	4.7	ns
			Open-Drain Driving	8	7	
t <sub>fA</sub>	A Ports Fall Time		Push-Pull Driving	7.3	7.6	ns
			Open-Drain Driving	3.1	3.0	
t <sub>fB</sub>	B Ports Fall Time		Push-Pull Driving	7.7	7.3	ns
			Open-Drain Driving	3.8	4.6	
Data Rate			Push-Pull Driving	24	24	Mbps
			Open-Drain Driving	2	2	

## SWITCHING CHARACTERISTICS (continued)

(T<sub>A</sub> = +25°C, V<sub>CCA</sub> = 5V, unless otherwise noted. )

PARAMETER	FROM (INPUT)	TO (OUTPUT)	TEST CONDITIONS	V <sub>CCB</sub> = 5V	UNITS
				TYP	
t <sub>PHL</sub>	A	B	Push-Pull Driving	5.3	ns
			Open-Drain Driving	27.4	
t <sub>PLH</sub>			Push-Pull Driving	2.4	
			Open-Drain Driving	51	
t <sub>PHL</sub>	B	A	Push-Pull Driving	5.0	ns
			Open-Drain Driving	26.3	
t <sub>PLH</sub>			Push-Pull Driving	2.2	
			Open-Drain Driving	49	
t <sub>EN</sub> (t <sub>PZH</sub> & t <sub>PZL</sub> )	OE	A or B		23	ns
t <sub>DIS</sub> (t <sub>PHZ</sub> & t <sub>PLZ</sub> )	OE	A or B		665	
t <sub>rA</sub>	A Ports Rise Time		Push-Pull Driving	5.3	ns
			Open-Drain Driving	5	
t <sub>rB</sub>	B Ports Rise Time		Push-Pull Driving	4.9	ns
			Open-Drain Driving	7	
t <sub>fA</sub>	A Ports Fall Time		Push-Pull Driving	8.5	ns
			Open-Drain Driving	2.8	
t <sub>fB</sub>	B Ports Fall Time		Push-Pull Driving	7.7	ns
			Open-Drain Driving	4.2	
Data Rate			Push-Pull Driving	24	Mbps
			Open-Drain Driving	2	



FUNCTIONAL BLOCK DIAGRAM

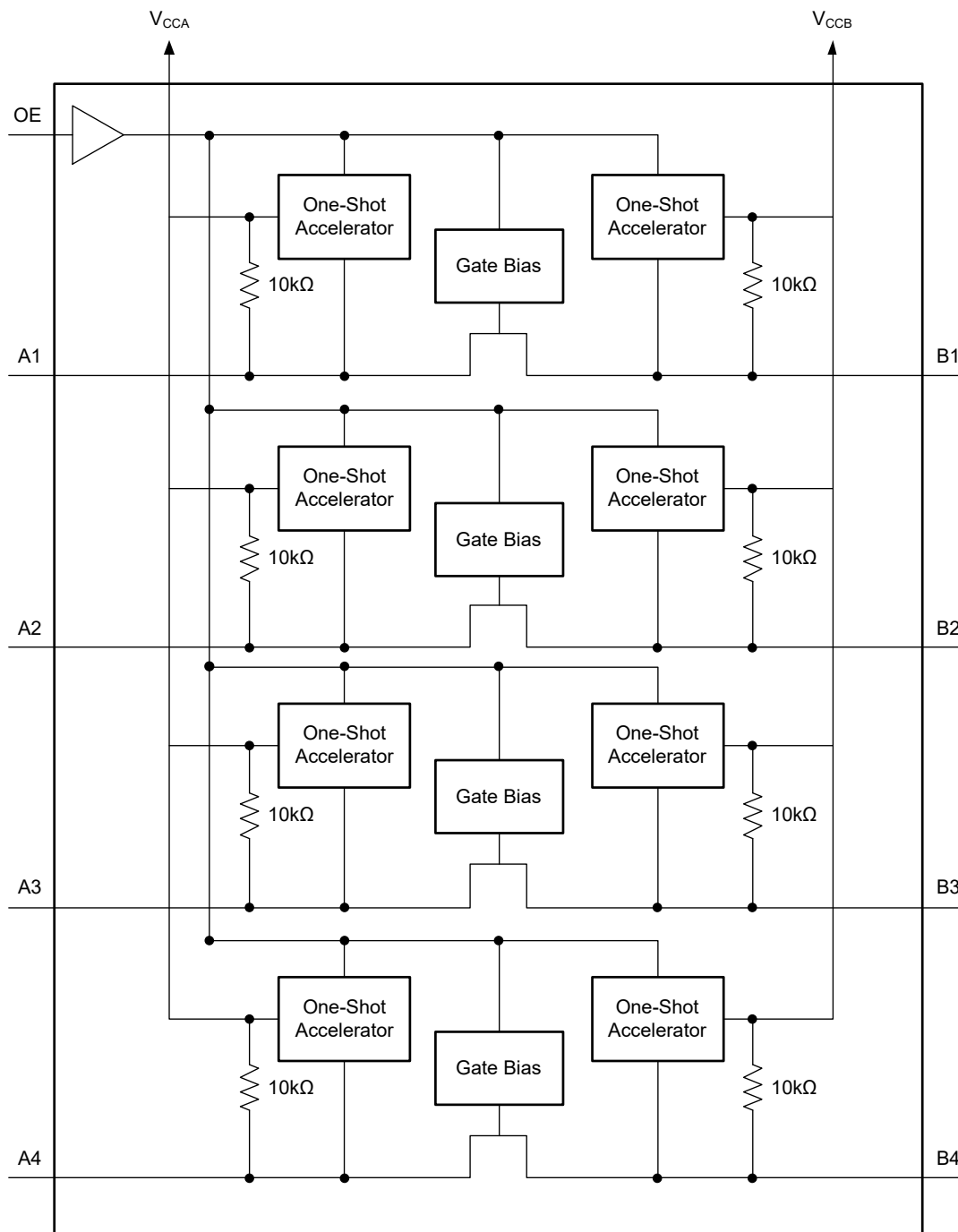
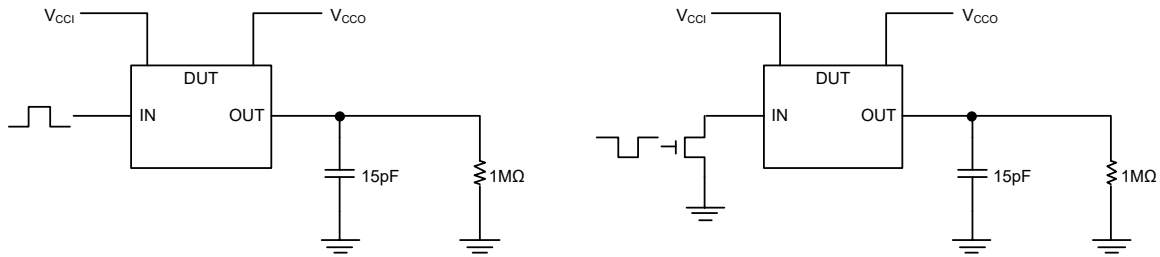

Figure 2. Block Diagram

PARAMETER MEASUREMENT INFORMATION



Data Rate, Pulse Duration, Propagation Delay, Output Rise-Time and Fall-Time Measurement Using A Push-Pull Driver

Data Rate (10pF), Pulse Duration (10pF), Propagation Delay, Output Rise-Time and Fall-Time Measurement Using An Open-Drain Driver

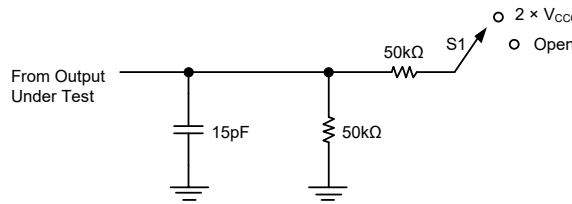

Load Circuit for Enable/Disable Time Measurement

TEST	S1
$t_{PZL}/t_{PLZ}$ ( $t_{DIS}$ )	$2 \times V_{CCO}$
$t_{PHZ}/t_{PZH}$ ( $t_{EN}$ )	Open

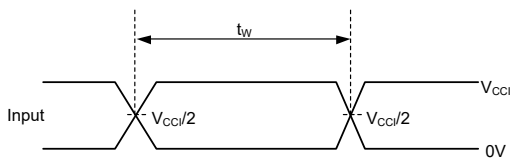

Voltage Waveforms Pulse Duration

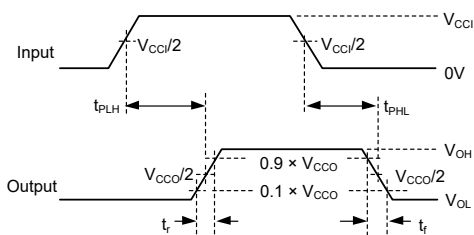

Voltage Waveforms Propagation Delay Times

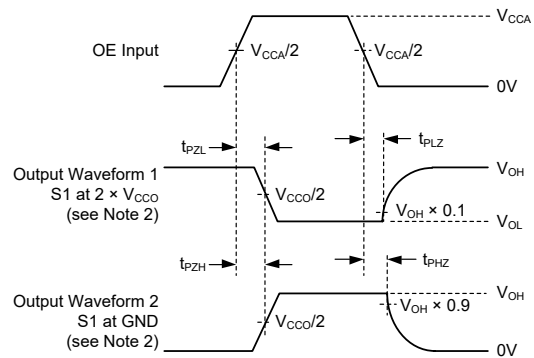

Voltage Waveforms Enable and Disable Times

Figure 3. Load Circuits and Voltage Waveforms

NOTES:

1.  $C_L$  includes probe and jig capacitance.
2. Waveform 1 is for an output with internal such that the output is high, except when OE is high. Waveform 2 is for an output with conditions such that the output is low, except when OE is high.
3. All input pulses are supplied by generators having the following characteristics: PRR  $\leq$  10MHz,  $Z_O = 50\Omega$ ,  $dv/dt \geq 1V/ns$ .
4. The outputs are measured one at a time, with one transition per measurement.
5.  $t_{PLZ}$  and  $t_{PHZ}$  are the same as  $t_{DIS}$ .
6.  $t_{PZL}$  and  $t_{PZH}$  are the same as  $t_{EN}$ .
7.  $t_{PLH}$  and  $t_{PHL}$  are the same as  $t_{PD}$ .
8.  $V_{CCI}$  is the  $V_{CC}$  associated with the input ports.
9.  $V_{CCO}$  is the  $V_{CC}$  associated with the output ports.

DETAILED DESCRIPTION

Overview

The SGM4574 is a directionless voltage-level translator specifically designed for translating logic voltage levels. The A ports are able to accept I/O voltages ranging from 1.65V to 5.5V, while the B ports can accept I/O voltages from 2.3V to 5.5V. The device is a pass gate architecture with edge rate accelerators (one-shots) to improve the overall data rate. 10kΩ pull-up resistors, commonly used in open-drain applications, have been conveniently integrated so that an external resistor is not needed. While this device is designed for open-drain applications, the device can also translate push-pull CMOS logic outputs.

Feature Description

Architecture

The SGM4574 architecture (see Figure 4) does not require a direction-control signal in order to control the direction of data flow from A to B or from B to A.

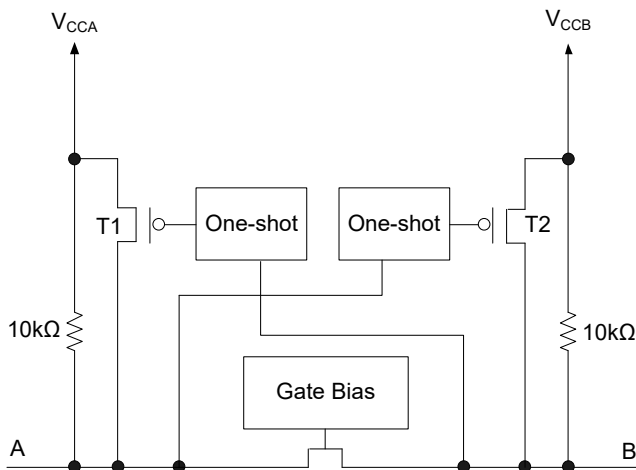

Figure 4. Architecture of a SGM4574 Cell

Each A port I/O has an internal 10kΩ pull-up resistor to V<sub>CCA</sub>, and each B port I/O has an internal 10kΩ pull-up resistor to V<sub>CCB</sub>. The output one-shots detect rising edges on the A or B ports. During a rising edge, the one-shot turns on the PMOS transistors (T1, T2) for a short duration which speeds up the low-to-high transition.

Input Driver Requirements

The fall time (t<sub>fA</sub>, t<sub>fB</sub>) of a signal depends on the output impedance of the external device driving the data I/Os of the SGM4574. Similarly, the t<sub>pHL</sub> and data rates also depend on the output impedance of the external driver. The values for t<sub>fA</sub>, t<sub>fB</sub>, t<sub>pHL</sub>, and data rates in the datasheet assume that the output impedance of the external driver is less than 50Ω.

Power Up

During operation, ensure that V<sub>CCA</sub> ≤ V<sub>CCB</sub> at all times. During power-up sequencing, V<sub>CCA</sub> ≥ V<sub>CCB</sub> does not damage the device, so any power supply can be ramped up first.

Enable and Disable

The SGM4574 has an OE input that disables the device by setting OE low, which places all I/Os in the high-impedance state. The disable time (t<sub>DIS</sub>) indicates the delay between the time when the OE pin goes low and when the outputs actually enter the high-impedance state. The enable time (t<sub>EN</sub>) indicates the amount of time the user must allow for the one-shot circuitry to become operational after the OE pin is taken high.

Pull-Up and Pull-Down Resistors on I/O Lines

Each A port I/O has an internal 10kΩ pull-up resistor to V<sub>CCA</sub>, and each B port I/O has an internal 10kΩ pull-up resistor to V<sub>CCB</sub>. If a smaller value of pull-up resistor is required, an external resistor must be added from the I/O to V<sub>CCA</sub> or V<sub>CCB</sub> (in parallel with the internal 10kΩ resistors).

Device Functional Modes

The SGM4574 has two functional modes, enabled and disabled. To disable the device set the OE input low, which places all I/Os in a high impedance state. Setting the OE input high will enable the device.

## APPLICATION INFORMATION

The SGM4574 can be used in level-translation applications for interfacing devices or systems operating at different interface voltages with one another. The SGM4574 is ideal for use in applications where an open-drain driver is connected to the data I/Os. The SGM4574 can also be used in applications where a push-pull driver is connected to the data I/Os, but the SGM4574 might be a better option for such push-pull applications.

### Design Requirements

For this design example, use the parameters listed in Table 1.

**Table 1. Design Parameters**

DESIGN PARAMETER	EXAMPLE VALUE
Input Voltage Range	1.65V to 5.5V
Output Voltage Range	2.3V to 5.5V

### Detailed Design Procedure

To begin the design process, determine the following:

- Input voltage range

Use the supply voltage of the device that is driving the SGM4574 to determine the input voltage range. For a valid logic high the value must exceed the  $V_{IH}$  of the input port. For a valid logic low the value must be less than the  $V_{IL}$  of the input port.

- Output voltage range

Use the supply voltage of the device that the SGM4574 is driving to determine the output voltage range.

The SGM4574 has 10k $\Omega$  internal pull-up resistors. External pull-up resistors can be added to reduce the total RC of a signal trace if necessary.

- An external pull-down resistor decreases the output  $V_{OH}$  and  $V_{OL}$ . Use Equation 1 to calculate the  $V_{OH}$  as a result of an external pull-down resistor.

$$V_{OH} = V_{CCX} \times R_{PD} / (R_{PD} + 10k\Omega) \quad (1)$$

where,

$V_{CCX}$  is the supply voltage on either  $V_{CCA}$  or  $V_{CCB}$ .  
 $R_{PD}$  is the value of the external pull down resistor.

### Power Supply Recommendations

The SGM4574 uses two separate configurable power-supply rails,  $V_{CCA}$  and  $V_{CCB}$ .  $V_{CCB}$  accepts any supply voltage from 2.3V to 5.5V and  $V_{CCA}$  accepts any supply voltage from 1.65V to 5.5V as long as  $V_S$  is less than or equal to  $V_{CCB}$ . The A ports and B ports are designed to track  $V_{CCA}$  and  $V_{CCB}$  respectively allowing for low-voltage bidirectional translation between any of the 1.8V, 2.5V, 3.3V, and 5V voltage nodes.

The SGM4574 does not require power sequencing between  $V_{CCA}$  and  $V_{CCB}$  during power-up so the power-supply rails can be ramped in any order. A  $V_{CCA}$  value greater than or equal to  $V_{CCB}$  ( $V_{CCA} \geq V_{CCB}$ ) does not damage the device, but during operation,  $V_{CCA}$  must be less than or equal to  $V_{CCB}$  ( $V_{CCA} \leq V_{CCB}$ ) at all times.

The output-enable (OE) input circuit is designed so that it is supplied by  $V_{CCA}$  and when the (OE) input is low, all outputs are placed in the high-impedance state. To ensure the high-impedance state of the outputs during power up or power down, the OE input pin must be tied to GND through a pull-down resistor and must not be enabled until  $V_{CCA}$  and  $V_{CCB}$  are fully ramped and stable. The minimum value of the pull-down resistor to ground is determined by the current-sourcing capability of the driver.

### Layout Guidelines

To ensure reliability of the device, following common printed-circuit board layout guidelines is recommended.

- Bypass capacitors should be used on power supplies.
- Short trace lengths should be used to avoid excessive loading.
- PCB signal trace-lengths must be kept short enough so that the round-trip delay of any reflection is less than the one-shot duration, approximately 30ns, ensuring that any reflection encounters low impedance at the source driver.
- Placing pads on the signal paths for loading capacitors or pull-up resistors to help adjust rise and fall times of signals depending on the system requirements.

**PACKAGE OUTLINE DIMENSIONS**

**TQFN-2×2-12L**

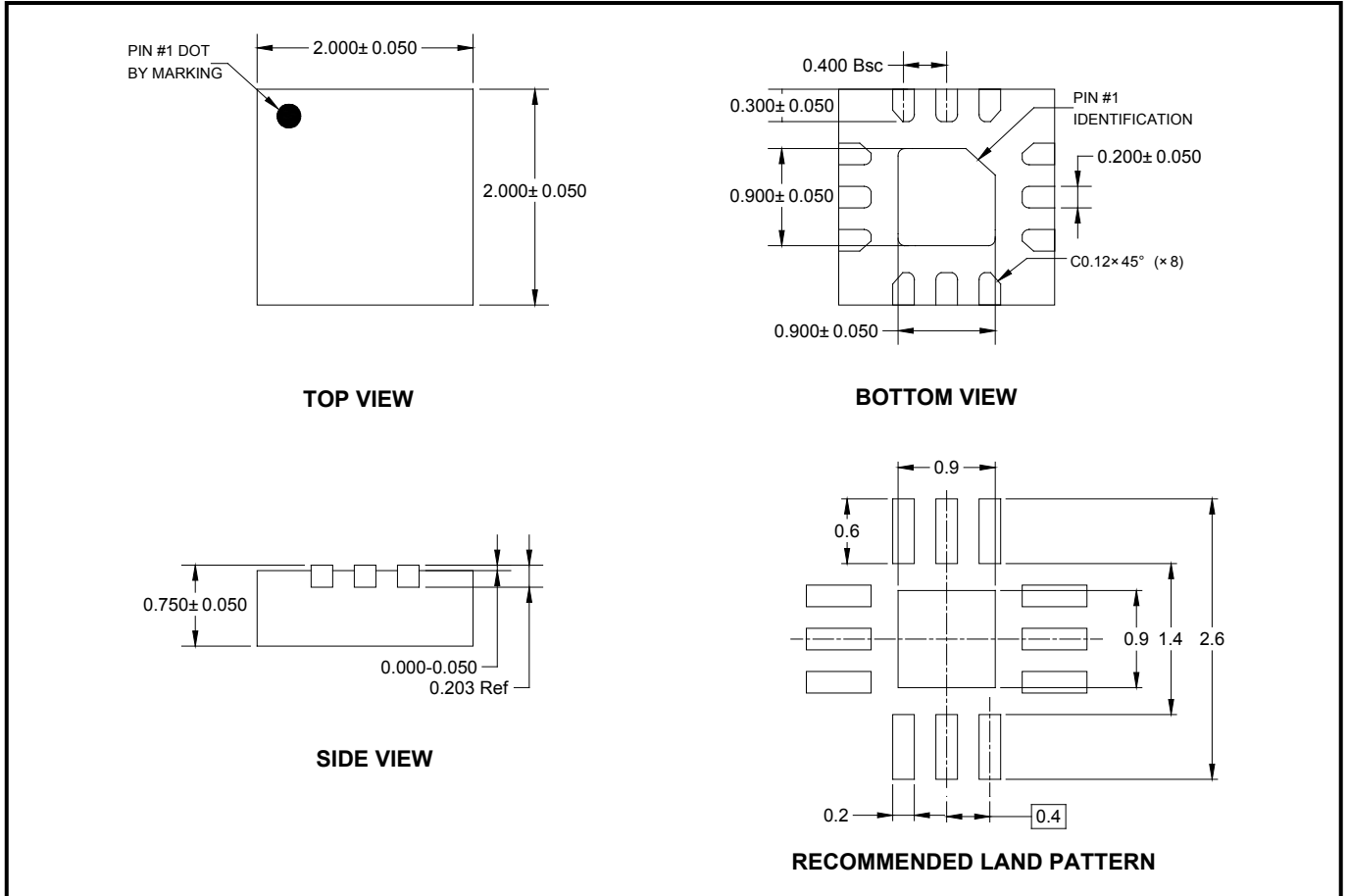

NOTE: All linear dimensions are in millimeters.

PACKAGE OUTLINE DIMENSIONS

UTQFN-1.8×1.8-12L

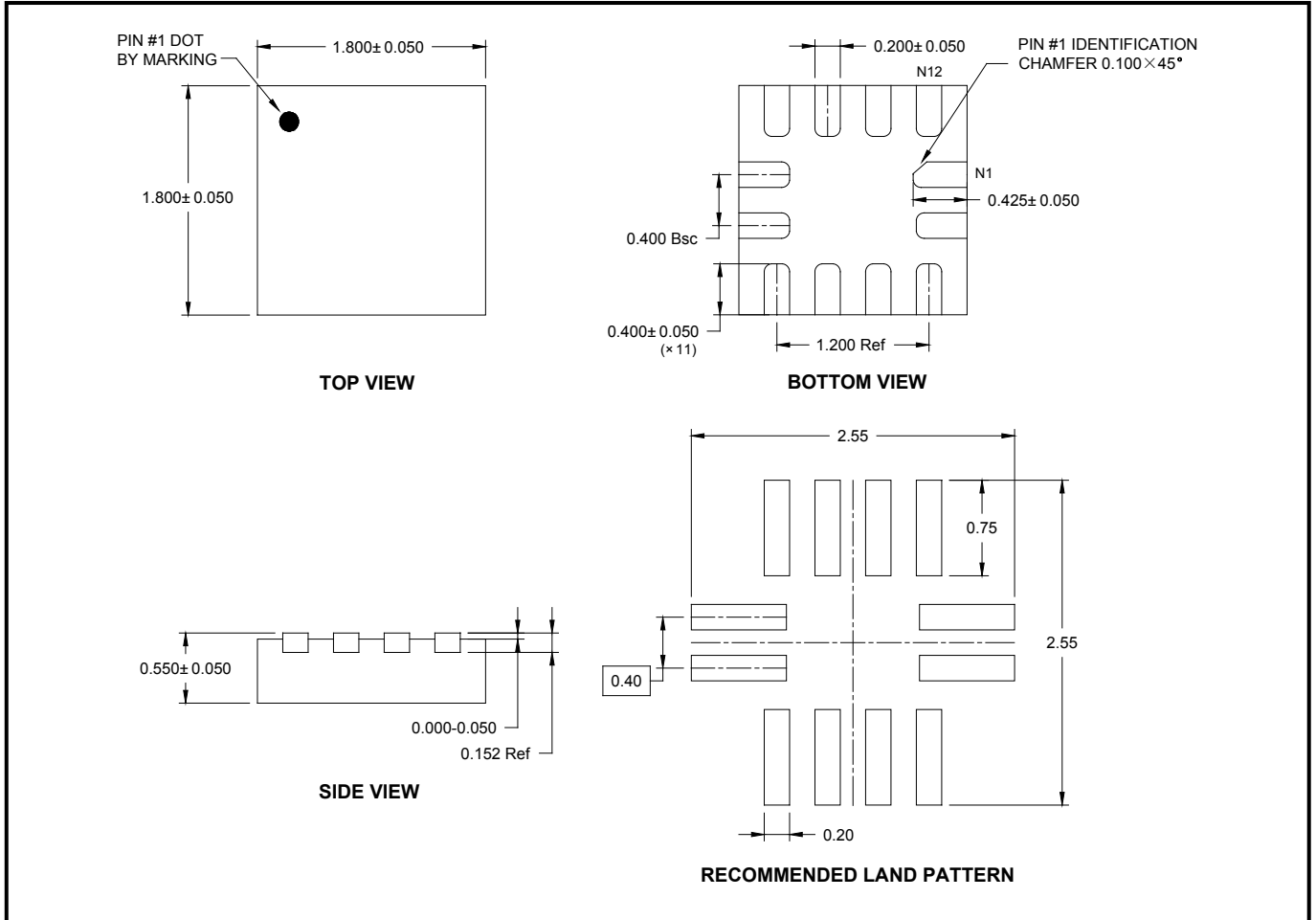

NOTE: All linear dimensions are in millimeters.

PACKAGE OUTLINE DIMENSIONS

SOIC-14

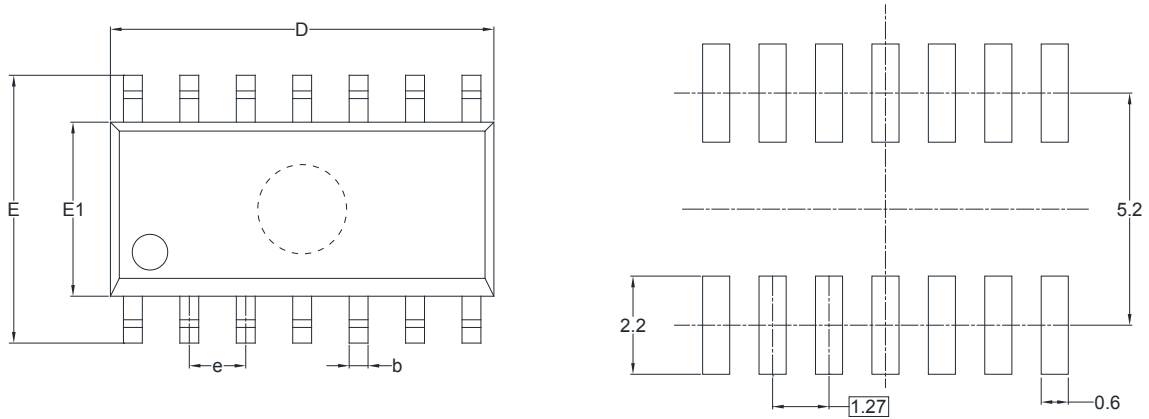

RECOMMENDED LAND PATTERN (Unit: mm)

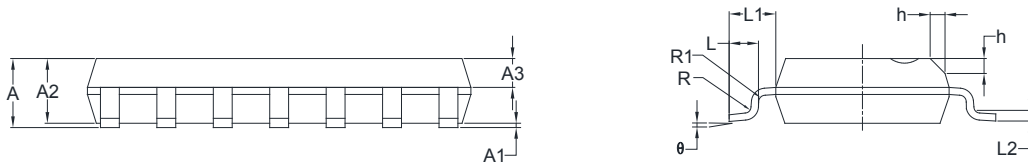

Symbol	Dimensions In Millimeters		Dimensions In Inches	
	MIN	MAX	MIN	MAX
A	1.35	1.75	0.053	0.069
A1	0.10	0.25	0.004	0.010
A2	1.25	1.65	0.049	0.065
A3	0.55	0.75	0.022	0.030
b	0.36	0.49	0.014	0.019
D	8.53	8.73	0.336	0.344
E	5.80	6.20	0.228	0.244
E1	3.80	4.00	0.150	0.157
e	1.27 BSC		0.050 BSC	
L	0.45	0.80	0.018	0.032
L1	1.04 REF		0.040 REF	
L2	0.25 BSC		0.01 BSC	
R	0.07		0.003	
R1	0.07		0.003	
h	0.30	0.50	0.012	0.020
θ	0°	8°	0°	8°

# PACKAGE INFORMATION

## TAPE AND REEL INFORMATION

### REEL DIMENSIONS

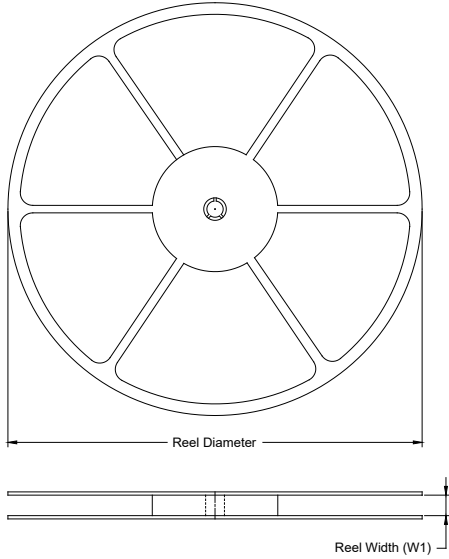

### TAPE DIMENSIONS

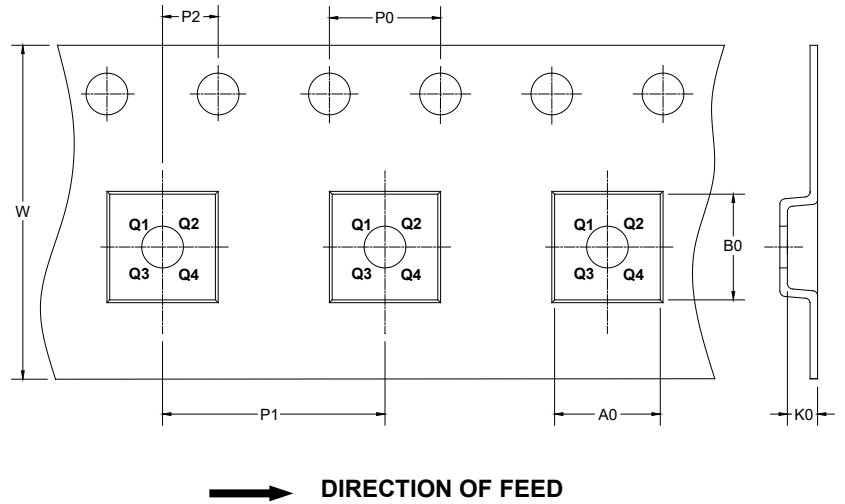

NOTE: The picture is only for reference. Please make the object as the standard.

### KEY PARAMETER LIST OF TAPE AND REEL

Package Type	Reel Diameter	Reel Width W1 (mm)	A0 (mm)	B0 (mm)	K0 (mm)	P0 (mm)	P1 (mm)	P2 (mm)	W (mm)	Pin1 Quadrant
TQFN-2×2-12L	7"	9.5	2.30	2.30	0.90	4.0	4.0	2.0	8.0	Q2
UTQFN-1.8×1.8-12L	7"	9.0	2.10	2.10	0.80	4.0	4.0	2.0	8.0	Q2
SOIC-14	13"	16.4	6.60	9.30	2.10	4.0	8.0	2.0	16.0	Q1

DD0001



# PACKAGE INFORMATION

## CARTON BOX DIMENSIONS

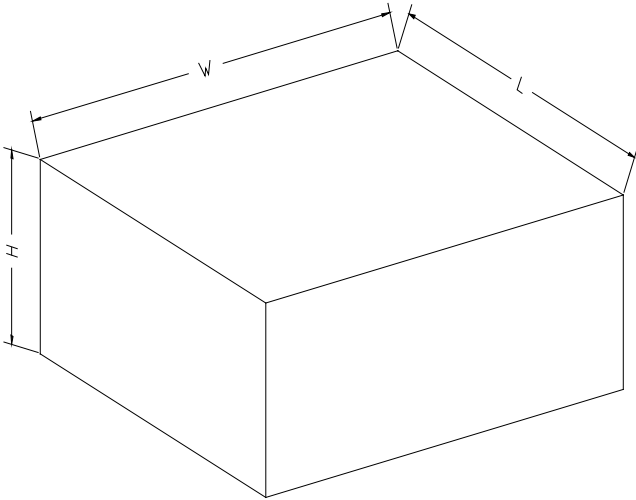

NOTE: The picture is only for reference. Please make the object as the standard.

## KEY PARAMETER LIST OF CARTON BOX

Reel Type	Length (mm)	Width (mm)	Height (mm)	Pizza/Carton
7" (Option)	368	227	224	8
7"	442	410	224	18
13"	386	280	370	5

DD0002