

3A,40V,200KHz Step-Down Converter

DESCRIPTION

The EUP3453 is current mode, step-down switching regulator capable of driving 3A continuous load with excellent line and load regulation. The EUP3453 operates with an input voltage range from 4.75V to 40V and the output voltage is externally set from 0.92V to 15V with a resistor divider. The output current threshold is programmed by an external resistor. The EUP3453 enters into the CC (constant current) mode when output reaches over current threshold. The OV (over voltage) threshold is programmed by an external resistor divider. The EUP3453 stops switching when output reaches over voltage threshold.

Fault condition protection includes secondary cycle-by-cycle current limit and thermal shutdown. In shutdown mode the regulator draws 3 μ A of supply current. Internal soft-start minimizes the inrush supply current and the output overshoot at initial startup.

The EUP3453 require a minimum number of external components.

FEATURES

- 4.75V to 40V Wide Input Operating Range
- Output Adjustable from 0.92V to 15V
- Up to 3A Output Current
- Programmable Output Current Threshold
- Programmable Output Over Voltage Threshold
- 3 μ A Low Shutdown Current
- 0.1 Ω Internal DMOS Output Switch
- Up to 95% Efficiency
- Fixed 200kHz Switching Frequency
- Internal Soft Start
- Secondary Cycle-by-Cycle Current Limit
- Thermal Shutdown
- Input Supply Undervoltage Lockout
- Available SOP-8 (EP) Package
- RoHS Compliant and 100% Lead(Pb)-Free Halogen-Free

APPLICATIONS

- Car Charger/Adaptor
- Rechargeable Portable Devices
- Distributive Power Systems
- Pre-regulator for Linear Regulators

Typical Application Circuit

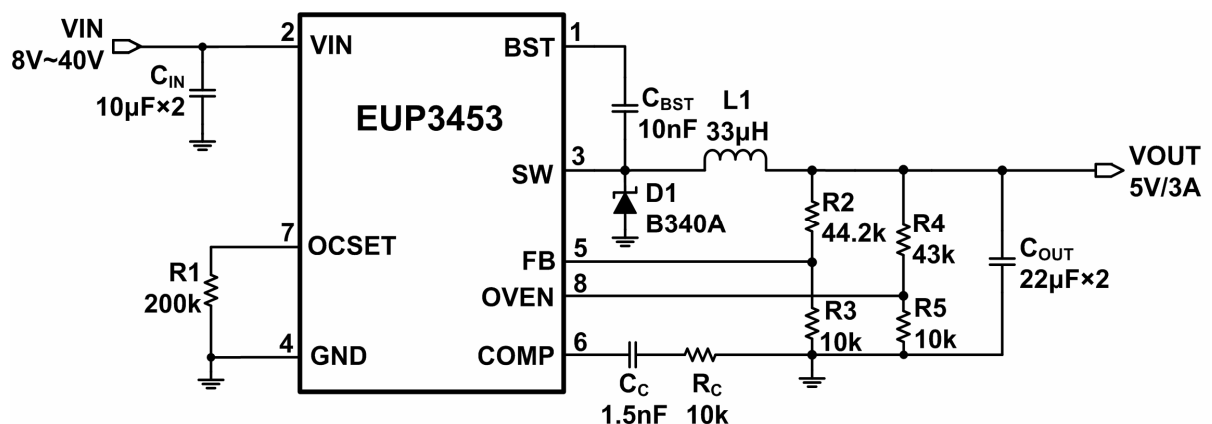

Figure 1. 5V Application Circuit

Pin Configurations

Package Type	Pin Configurations
SOP-8 (EP)	<p>(Top View)</p>

Pin Description

Pin Name	SOP-8 (EP)	DESCRIPTION
BST	1	High-Side Gate Driver Bootstrap Supply. BST provides power to the gate driver of high-side n-channel MOSFET switch. Connect a 10nF or greater capacitor from SW to BST.
VIN	2	Input Supply Pin. IN supplies the power to the IC and the high side power switch. Connect IN to a 4.75V to 40V power source. Bypass IN to GND with a suitably large value capacitor to minimize input ripple to the IC. <i>See Input Capacitor Section of the applications notes.</i>
SW	3	Power Switcher Output. Connect the output LC filter from SW to the output.
GND	4	Ground.
FB	5	Output Feedback Input. FB senses the output voltage to regulate that voltage. Connect FB to an external resistor divider to set the output voltage. The feedback threshold is 0.92V. <i>See Setting the Output Voltage.</i>
COMP	6	Loop compensation pin. Connect a series RC network from COMP to GND to compensate the regulation control loop. <i>See Compensation.</i>
OCSET	7	OC (output current) threshold setting pin. Connect a resistor from OCSET to GND to program the output current. <i>See Setting the Output Current Threshold.</i>
OVEN	8	OV (output over voltage) threshold setting pin and enable Input. Must Connect to a resistor divider between VOUT and GND to set the output over voltage threshold and achieve automatic startup. Drive OVEN logic high to turn off the regulator. Don't leave OVEN pin floating. <i>See Setting the Output Over Voltage Threshold.</i>
Thermal Pad	-	Ground. (Thermal pad must be connected to the ground of PCB.)

Ordering Information

Order Number	Package Type	Marking	Operating Temperature Range
EUP3453WIR1	SOP-8 (EP)	 xxxxx P3453	-40°C to +85°C

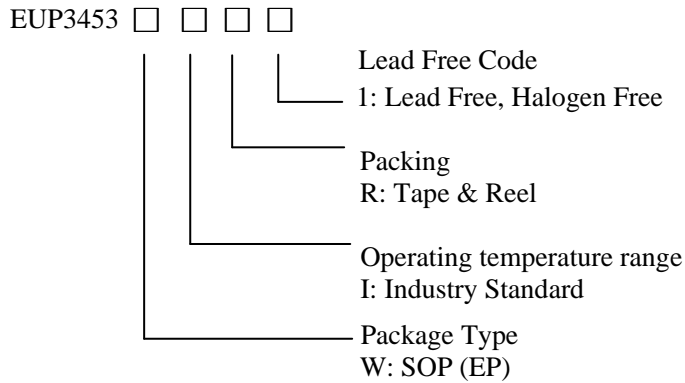

Block Diagram

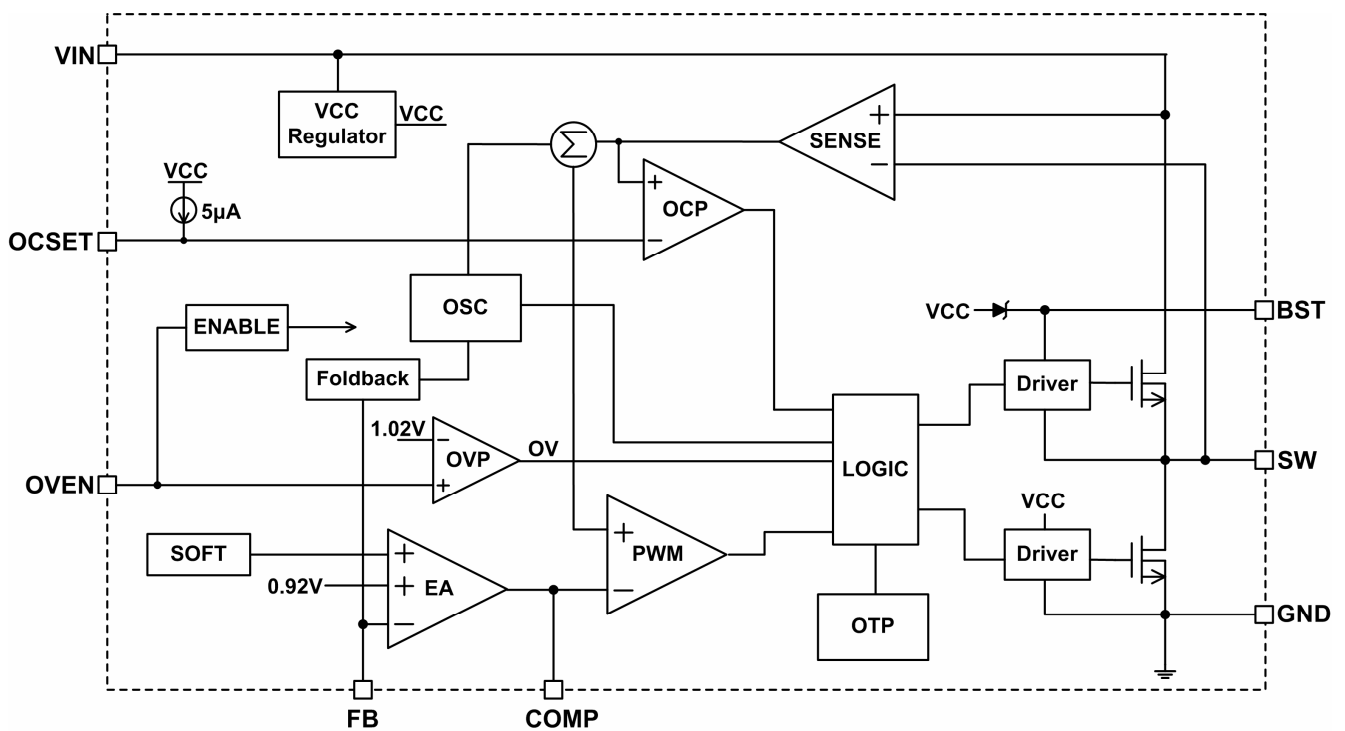

Figure 2. Functional Block Diagram

Absolute Maximum Ratings (1)

- Input Voltage (V_{IN}) ----- -0.3V to 42V
- Switch Voltage (V_{SW}) ----- -1V to $V_{IN}+0.3V$
- Boot Strap Voltage (V_{BST}) ----- $V_{SW}-0.3V$ to $V_{SW}+6V$
- All Other Pins ----- -0.3V to 6V
- Junction Temperature ----- 150°C
- Storage Temperature ----- -65°C to +150°C
- Lead Temp (Soldering, 10sec) ----- 260°C
- Thermal Resistance θ_{JA} (SOP-8_EP) ----- 60°C/W

Recommend Operating Conditions (2)

- Supply Voltage (V_{IN}) ----- 4.75V to 40V
- Operating Temperature Range ----- -40°C to +85°C

Note (1): Stress beyond those listed under “Absolute Maximum Ratings” may damage the device.

Note (2): The device is not guaranteed to function outside the recommended operating conditions.

Electrical Characteristics

The ● denote specifications which apply over the full operating temperature range, otherwise specifications are $T_A=+25^\circ\text{C}$. $V_{IN}=12\text{V}$ unless otherwise specified.

Parameter	Conditions	EUP3453			Unit	
		Min.	Typ.	Max.		
Feedback Voltage	$4.75\text{V} \leq V_{IN} \leq 40\text{V}$		0.902	0.920	0.938	V
		●	0.892	0.920	0.948	
High-Side Switch-On Resistance			0.1	0.16	Ω	
Low-Side Switch-On Resistance			10		Ω	
Switch Leakage	$V_{OVEN}=5\text{V}, V_{SW}=0\text{V}$			10	μA	
Current Limit		3.6	4.4	5.2	A	
Current Sense Transconductance	Output Current to V_{COMP}		4		A/V	
Error Amplifier Transconductance	$\Delta\text{IC} = \pm 10\mu\text{A}$	500	680	900	$\mu\text{A}/\text{V}$	
Oscillator Frequency		170	200	230	KHz	
Short Circuit Oscillation Frequency	$V_{FB} = 0\text{V}$		60		KHz	
Maximum Duty Cycle	$V_{FB} = 0.8\text{V}$		90		%	
Minimum On-Time			100		ns	
Input Under Voltage Lockout Threshold Rising		3.8	4.2	4.5	V	
Input Under Voltage Lockout Threshold Hysteresis			300		mV	
OVEN Enable Threshold Voltage				0.4	V	
OVEN Shutdown Threshold Voltage		2			V	
OCSET Pull Up Current		4.75	5.0	5.25	μA	
Shutdown Current	$V_{OVEN} = 5\text{V}$		3		μA	
Quiescent Current	$V_{OVEN} = 0\text{V}, V_{FB} = 1\text{V}$		0.55	1	mA	
Soft -Start Period			10		ms	
Thermal Shutdown			160		$^\circ\text{C}$	

Typical Operating Characteristics

$V_{IN}=12V$, $V_{OUT}=5V$, $C_{IN}=10\mu F \times 2$, $C_{OUT}=22\mu F \times 2$, $L1=33\mu H$, $T_A=25^\circ C$, unless otherwise noted.

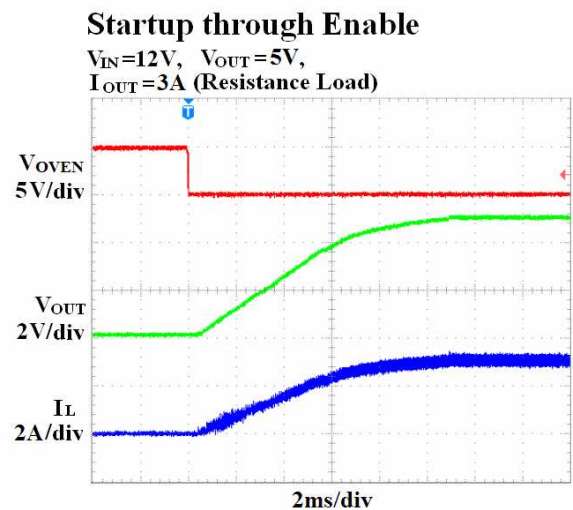
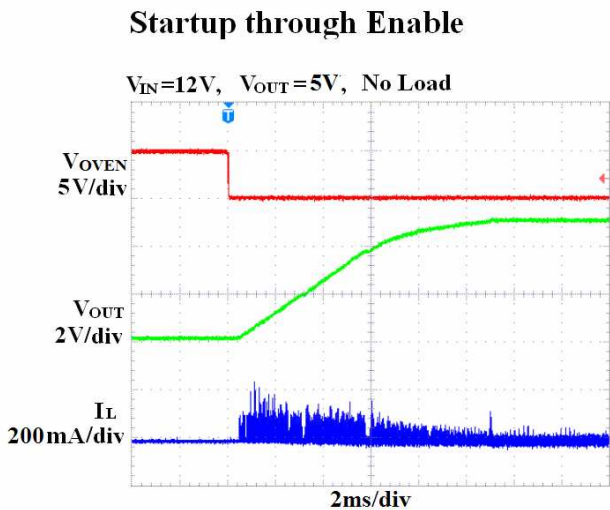
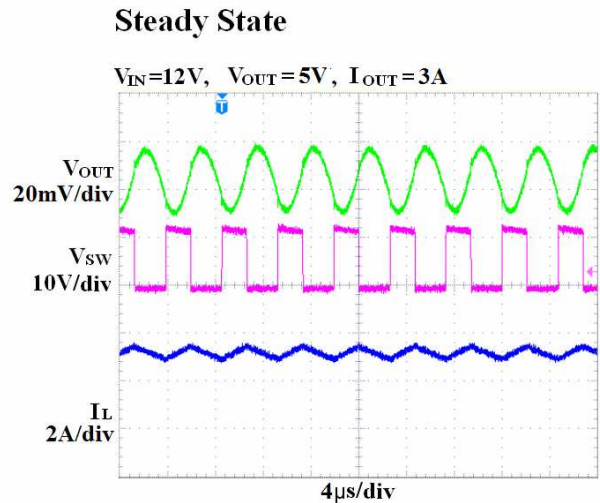
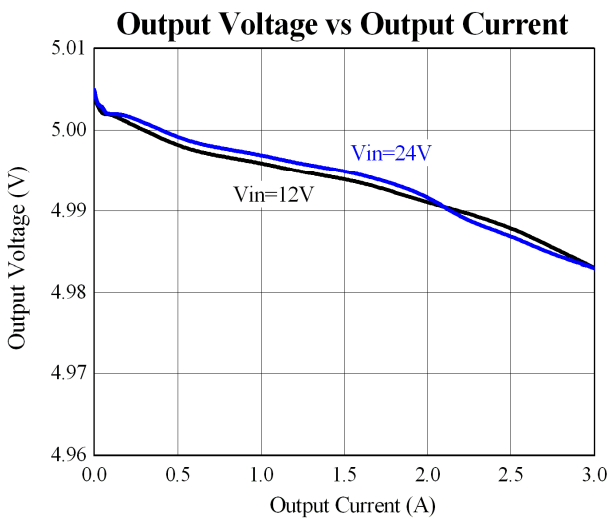
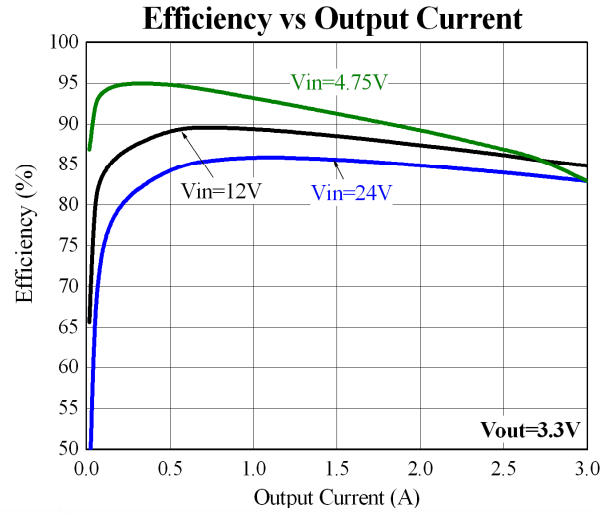
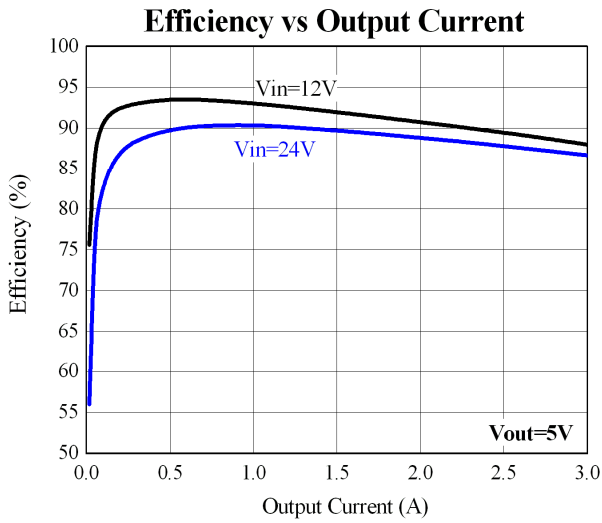

Typical Operating Characteristics (continued)

$V_{IN}=12V$, $V_{OUT}=5V$, $C_{IN}=10\mu F \times 2$, $C_{OUT}=22\mu F \times 2$, $L1=33\mu H$, $T_A=25^\circ C$, unless otherwise noted.

Startup into CC mode

$V_{IN}=12V$, $V_{OUT}=5V$,
 $R_{LOAD}=1.5\Omega$, $I_{OCSET}=2.7A$

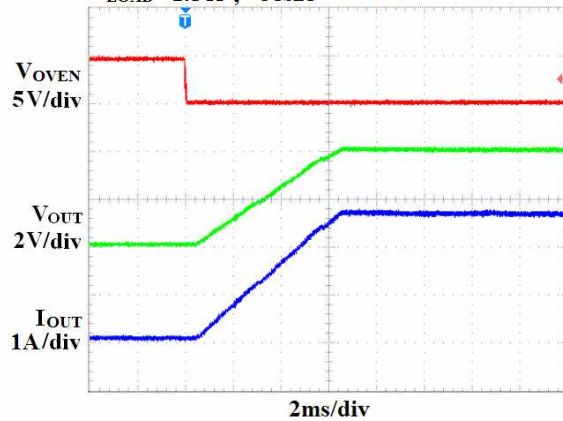

Startup into CC mode

$V_{IN}=24V$, $V_{OUT}=5V$,
 $R_{LOAD}=1.5\Omega$, $I_{OCSET}=2.7A$

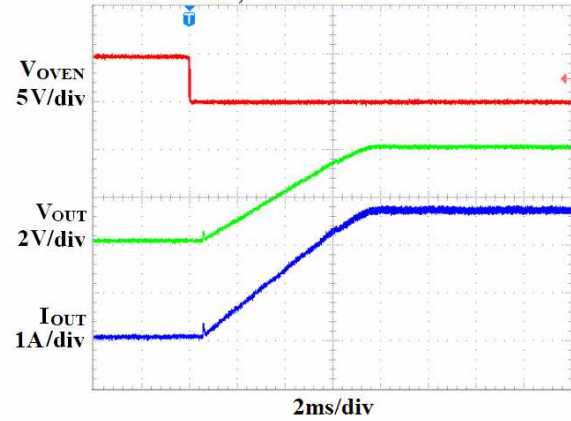

Shutdown through Enable

$V_{IN}=12V$, $V_{OUT}=5V$, No Load

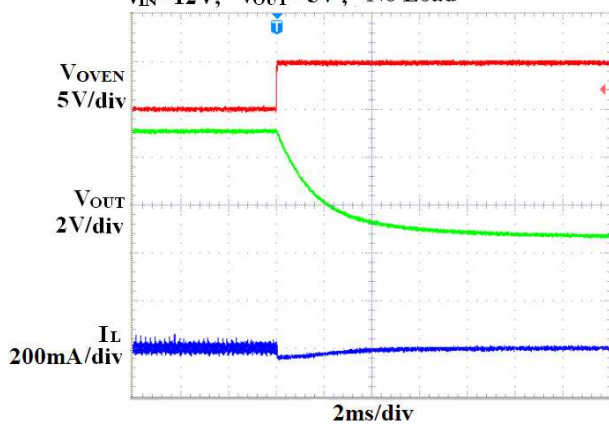

Shutdown through Enable

$V_{IN}=12V$, $V_{OUT}=5V$,
 $I_{OUT}=3A$ (Resistance Load)

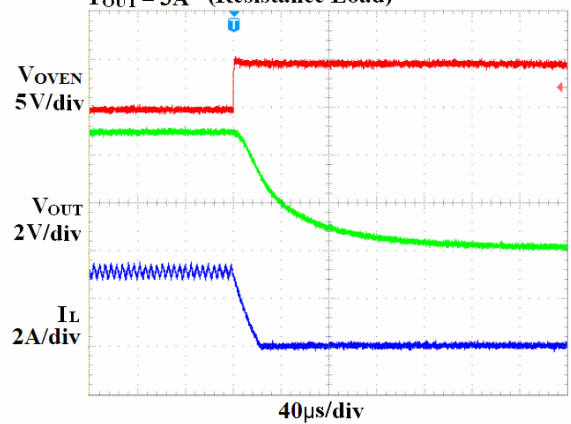

Short Circuit

$V_{IN}=12V$, $V_{OUT}=5V$, $I_{OCSET}=2.7A$

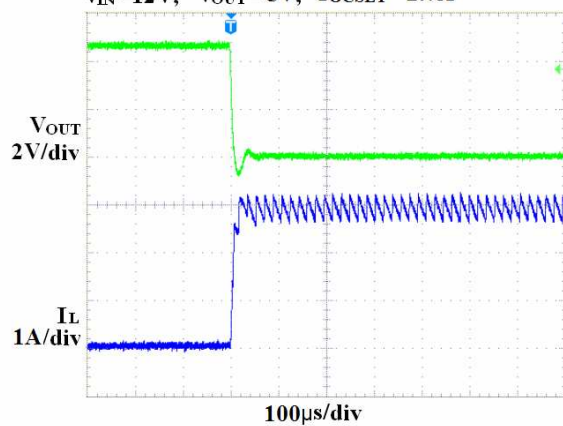

Short Circuit Recovery

$V_{IN}=12V$, $V_{OUT}=5V$, $I_{OCSET}=2.7A$

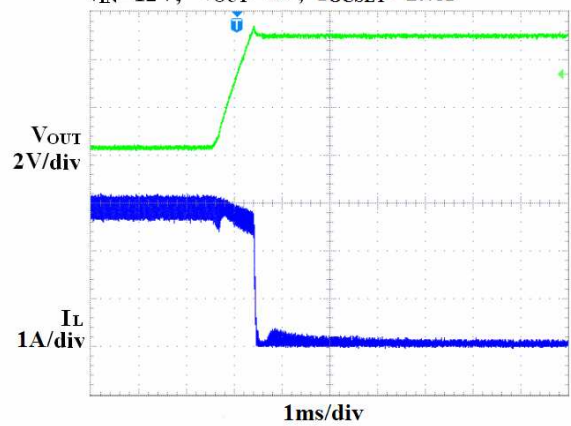

Typical Operating Characteristics (continued)

$V_{IN}=12V$, $V_{OUT}=5V$, $C_{IN}=10\mu F \times 2$, $C_{OUT}=22\mu F \times 2$, $L1=33\mu H$, $T_A=25^\circ C$, unless otherwise noted.

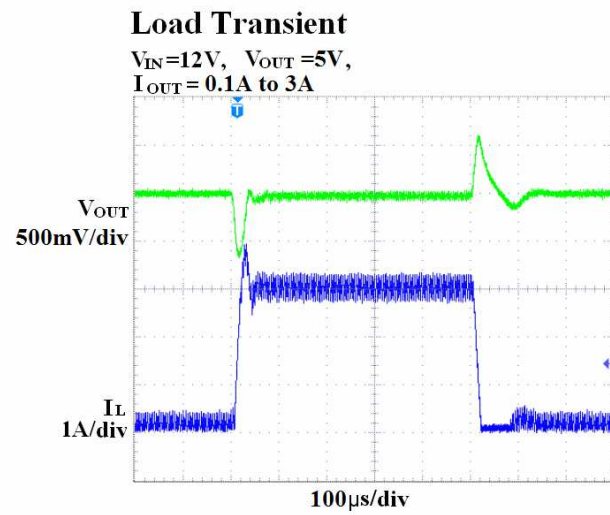
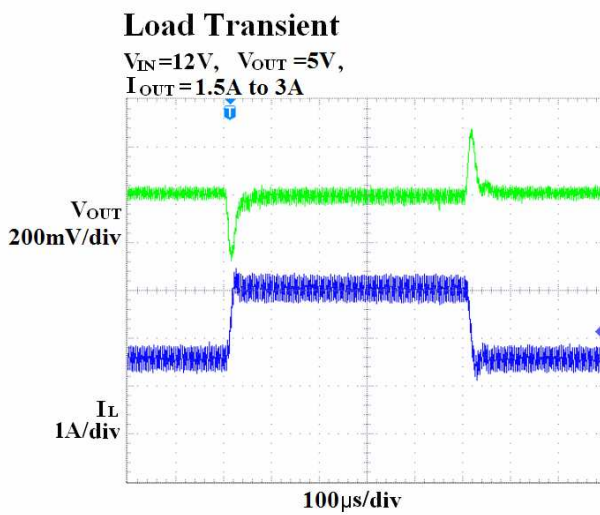
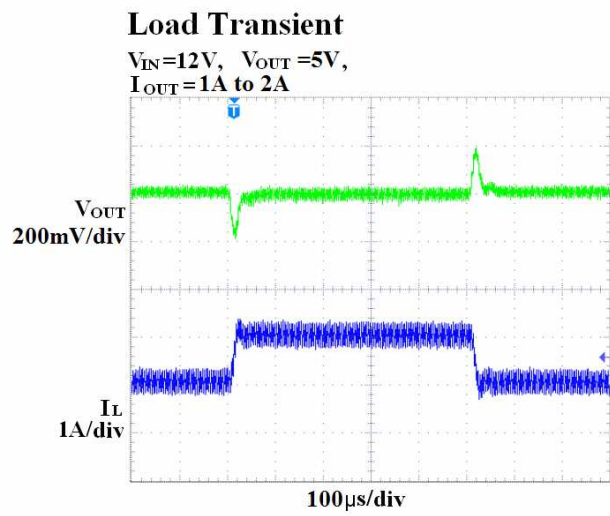
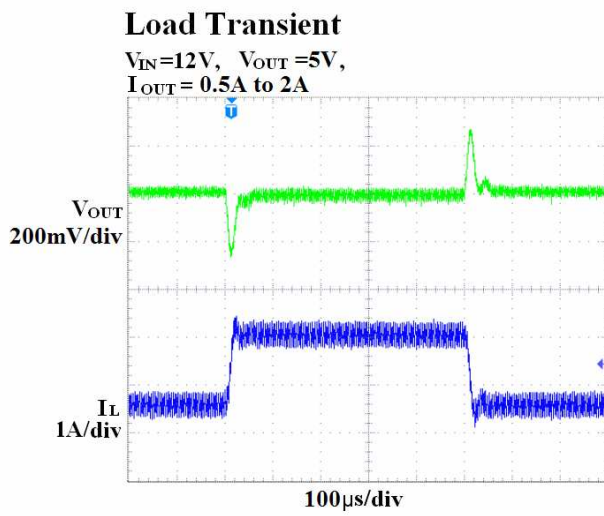

Functional Description

The EUP3453 is current-mode step-down switching regulator. The device regulates an output voltage as low as 0.92V from a 4.75V to 40V input power supply. The device can provide up to 3Amp continuous current to the output. The EUP3453 uses current-mode architecture to control the regulator loop. The output voltage is measured at FB through a resistive voltage divider and amplified through the internal error amplifier. The output current of the transconductance error amplifier is presented at COMP pin where a RC network compensates the regulator loop. Slope compensation is internally added to eliminate subharmonic oscillation at high duty cycle. The slope compensation adds voltage ramp to the inductor current signal which reduces maximum inductor peak current at high duty cycles.

The device uses an internal Hside n-channel switch to step down the input voltage to the regulated output voltage. Since the Hside n-channel switch requires gate voltage greater than the input voltage, a bootstrap BST capacitor is connected between SW and BST to drive the n-channel gate. The BST capacitor is internally charged while the switch is off. An internal 10Ω switch from SW to GND is added to insure that SW is pulled to GND when the switch is off to fully charge the BST capacitor.

The device has programmable OC(output current) threshold setting by OCSET resistor. Output current will increase until it reaches the OC threshold. At this point, the device will transfer from regulating output voltage to regulating output current, and the output voltage will drop with the increasing load.

The device has programmable OV(over voltage) threshold setting by OVEN resistor divider between VOUT and GND. When the output voltage VOUT is higher than OV threshold, the device will stop switching, then VOUT will decrease until it is below OV threshold.

Application Information

Setting the Output Voltage

The output voltage is set through a resistive voltage divider (see Figure1). The voltage divider divides the output voltage down by the ratio:

$$V_{FB} = V_{OUT} * R3 / (R2 + R3) = 0.92V$$

Thus the output voltage is :

$$V_{OUT} = 0.92V * (R2 + R3) / R3$$

Choose R3 value in the range 10k to 100k, R2 is determined by :

$$R2 = (V_{OUT} / 0.92 - 1) * R3$$

For example, for a 3.3V output voltage, R3 is 10KΩ, and R2 is 25.8KΩ.

Setting the Output Current Threshold

The output current threshold is set by a resistor connected between the OCSET pin and GND. The output current threshold is proportional to the OCSET pin voltage. The current flow out of OCSET pin is roughly 5μA and the transconductance gain from OCSET to output is roughly 4A/V. To determine the proper resistor value for a desired output current threshold, please refer to Figure 3 below.

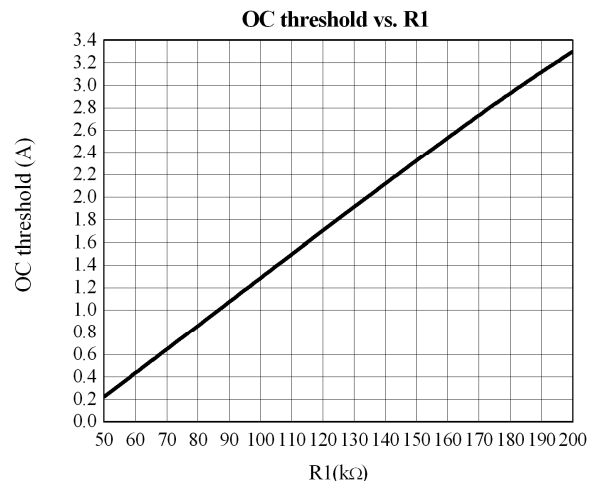

Figure 3. Curve for Setting OC Threshold

Setting the Output Over Voltage Threshold

The output over voltage threshold is set by a resistor divider connected between VOUT and GND. The OVEN voltage is set by the resistor R4 and R5 (see Figure 1) , the OVEN voltage is:

$$V_{OVEN} = V_{OUT} * R5 / (R4 + R5)$$

The OVEN pin voltage threshold is 1.02V. When OVEN voltage is higher than 1.02V, the regulator stop switching until OVEN voltage fall below 1.02V. Thus the output over voltage threshold is:

$$V_{OV} = 1.02V * (R4 + R5) / R5$$

Choose R4 and R5 value to set the output over voltage threshold.

Inductor

The inductor is required to supply constant current to the output load while being driven by the switched input voltage. A larger value inductor results in less ripple current and lower output ripple voltage. However, the larger value inductor has a larger physical size, higher series resistance, and lower saturation current. Choose an inductor that does not saturate under the worst-case load conditions. A good rule for determining the inductance is to allow the peak-to- peak ripple current in the inductor to be approximately 30% of the maximum load current. Also, make sure that the peak inductor current (the load current plus half the peak-to-peak

inductor ripple current) is below the 3.6A minimum peak current limit.

The inductance value can be calculated by the equation:

$$L = (V_{OUT}) * (V_{IN} - V_{OUT}) / (V_{IN} * f * \Delta I)$$

Where V_{OUT} is the output voltage, V_{IN} is the input voltage, f is the switching frequency, and ΔI is the peak-to-peak inductor ripple current.

Input Capacitor

The input current to the step-down converter is discontinuous, and therefore an input capacitor C1 is required to supply the AC current to the step-down converter while maintaining the DC input voltage. A low ESR capacitor is required to keep the noise minimum at the IC. Ceramic capacitors are preferred, but tantalum or low-ESR electrolytic capacitors may also suffice. The input capacitor value should be greater than 10 μ F, and the RMS current rating should be greater than approximately 1/2 of the DC load current. In Figure 1, all ceramic capacitors should be placed close to the EUP3453.

Output Capacitor

The output capacitor is required to maintain the DC output voltage. Low ESR capacitors are preferred to keep the output voltage ripple low. The characteristics of the output capacitor also affect the stability of the regulator control loop. In the case of ceramic capacitors, the impedance at the switching frequency is dominated by the capacitance. The output voltage ripple is estimated to be:

$$V_{RIPPLE} \approx 1.4 * V_{IN} * (f_{LC} / f)^2$$

Where V_{RIPPLE} is the output ripple voltage, V_{IN} is the input voltage, f_{LC} is the resonant frequency of the LC filter, f is the switching frequency.

Output Rectifier Diode

The output rectifier diode supplies the current to the inductor when the high-side switch is off. A schottky diode is recommended to reduce losses due to the diode forward voltage and recovery times.

Loop Compensation

The system stability is controlled through the COMP pin. COMP is the output of the internal transconductance error amplifier. A series capacitor-resistor combination sets a pole-zero combination to control the feedback loop.

The DC loop gain is:

$$A_{VDC} = (V_{FB} / V_{OUT}) * A_{VEA} * G_{CS} * R_{LOAD}$$

Where:

V_{FB} is the feedback threshold voltage, 0.92V

V_{OUT} is the desired output regulation voltage

A_{VEA} is the transconductance error amplifier voltage gain, 400 V/V

G_{CS} is the current sense gain, (roughly the output current divided by the voltage at COMP), 4A/V

R_{LOAD} is the load resistance (V_{OUT} / I_{OUT} where I_{OUT} is the output load current)

The system has 2 poles. One is due to the compensation capacitor (C3), and the other is due to the output capacitor (C2). These are:

$$f_{P1} = G_{EA} / (2\pi * A_{VEA} * C3)$$

Where P1 is the first pole, and G_{EA} is the error amplifier transconductance (820 μ A/V).

and

$$f_{P2} = 1 / (2\pi * R_{LOAD} * C2)$$

The system has one zero of importance, due to the compensation capacitor (C3) and the compensation resistor (R1). The zero is:

$$f_{Z1} = 1 / (2\pi * R1 * C3)$$

If a large value capacitor (C2) with relatively high equivalent-series-resistance (ESR) is used, the zero due to the capacitance and ESR of the output capacitor can be compensated by a third pole set by R1 and C4. The pole is:

$$f_{P3} = 1 / (2\pi * R1 * C4)$$

The system crossover frequency (the frequency where the loop gain drops to 1, or 0dB) is important. A good rule of thumb is to set the crossover frequency to approximately 1/10 of the switching frequency. In this case, the switching frequency is 400KHz, therefore use a crossover frequency, f_c , of 40KHz. Lower crossover frequency results in slower loop response and poor load transient performance. Higher crossover frequency can result in loop instability.

Table 1. External Components for Typical Designs

V_{IN} (V)	V_{OUT} (V)	R1 (K Ω)	R2 (K Ω)	RC (K Ω)	CC (nF)	L (μ H)	C_{OUT} (μ F)
12	3.3	25.8	10	10	1.5	22	22 \times 2
12	5	44.2	10	10	1.5	33	22 \times 2
24	3.3	25.8	10	10	1.5	22	22 \times 2
24	5	44.2	10	10	1.5	33	22 \times 2

To simplify design efforts using the EUP3453, the typical designs for common applications are listed in Table 1.

Packaging Information

SOP-8 (EP)

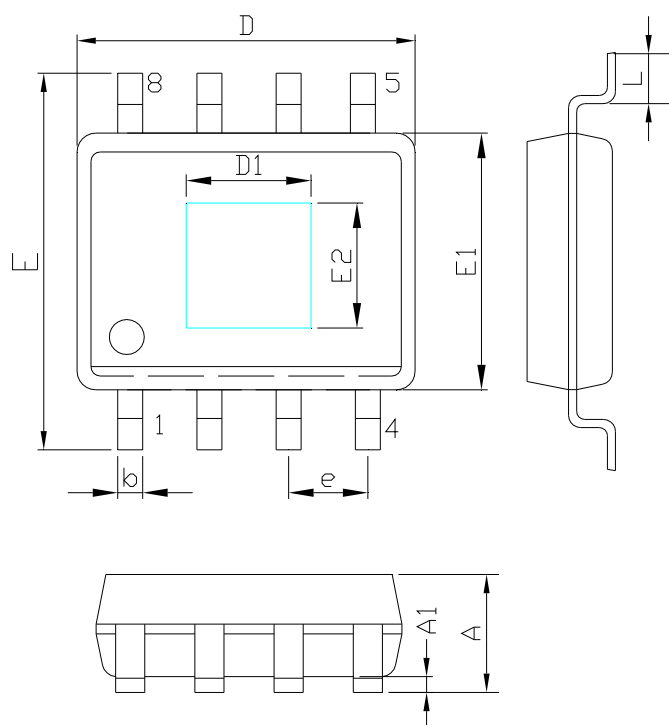

Remark: Exposed pad outline drawing is for reference only.

SYMBOLS	MILLIMETERS			INCHES		
	MIN.	Normal	MAX.	MIN.	Normal	MAX.
A	1.35	-	1.75	0.053	-	0.069
A1	0.00	-	0.25	0.000	-	0.010
D	4.80	4.90	5.00	0.189	0.193	0.197
E1	3.70	3.90	4.00	0.146	0.154	0.157
D1	2.67	2.97	3.50	0.105	0.117	0.138
E2	1.78	2.18	2.60	0.070	0.086	0.102
E	5.80	6.00	6.20	0.228	0.236	0.244
L	0.40	-	1.27	0.016	-	0.050
b	0.31	-	0.51	0.012	-	0.020
e	1.27 REF			0.050 REF		