

1.6A, 500KHz Synchronous Step-up Converter

DESCRIPTION

The EUP2410 is a highly efficient, synchronous, fixed frequency, current-mode step-up converter with output to input disconnect. When EUP2410 is disabled, the internal conduction path from SW to OUT is fully blocked and the OUT pin is isolated from the battery. This output disconnect feature reduces the shutdown current to typically only 50nA.

The 500KHz switching frequency allows for smaller external components producing a compact solution for a wide range of load currents. Highly integration and internal compensation network minimizes as 5 external components, N-Channel switch and P-Channel Synchronous switch integration will greatly improve converter efficiency. Internal soft-start function also reduce inrush current. The EUP2410 regulates the output voltage up to 6V from either a 2-cell NiMH/NiCd or a single-cell Li-Ion battery.

The EUP2410 is offered in a thin SOT23-5 package.

FEATURES

- Over 90% Efficiency
- 1.6A Typical Switch Current Limit
- 500KHz Fixed Switching Frequency
- Output to Input Disconnect at Shutdown Mode
- Internal Synchronous Rectifier
- Internal Soft-Start
- Internal Compensation
- 50nA Shutdown Current
- Thermal Shutdown
- 5-Pin TSOT-23 Package
- RoHS compliant and 100% lead(Pb)-free

APPLICATIONS

- GPS PND
- Handheld Digital Audio
- Digital Still and Video Cameras
- White LED Flash

Typical Application Circuit

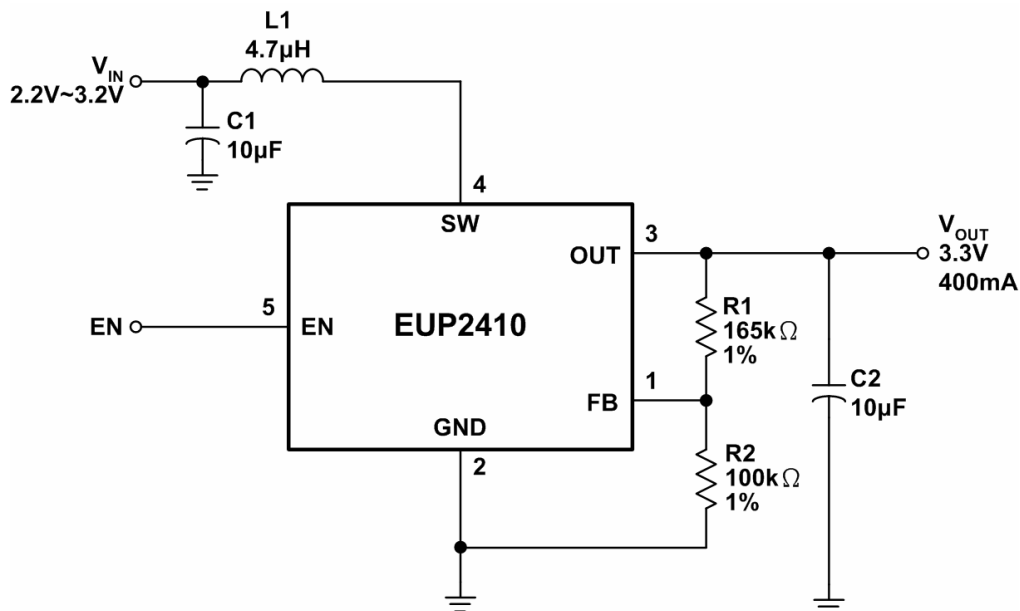
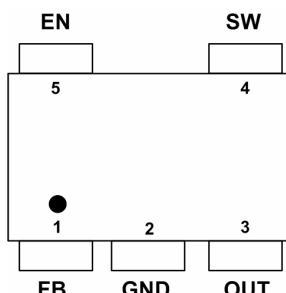

Figure1.

Pin Configurations

Package Type	Pin Configurations
TSOT23-5	

Pin Description

PIN	NAME	DESCRIPTION
1	FB	Regulation Feedback Input. Connect to an external resistive voltage divider from the output to FB to set the output voltage.
2	GND	Ground.
3	OUT	Supply Input for the EUP2410. Connect to the output of the converter.
4	SW	Output Switching Node. SW is the drain of the internal low-side N-Channel MOSFET and high-side P-Channel MOSFET. Connect the inductor to SW to complete the step-up converter.
5	EN	Regulator On/Off Control Input. A logic high input ($V_{EN} > 1.4V$) turns on the regulator. A logic low input ($V_{EN} < 0.4V$) puts the EUP2410 into low current shutdown mode.

Block Diagram

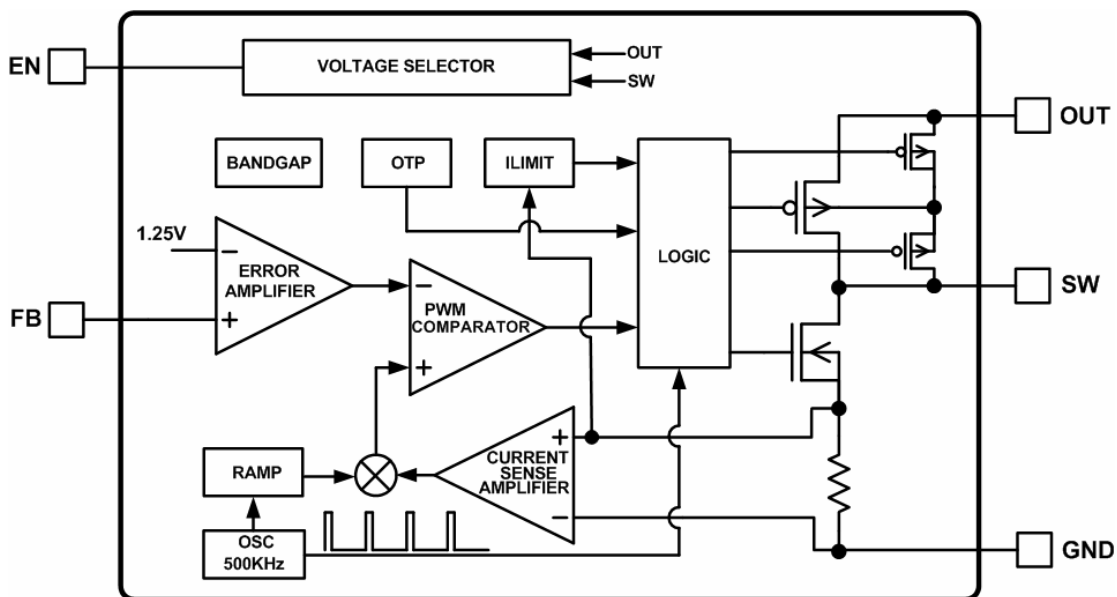
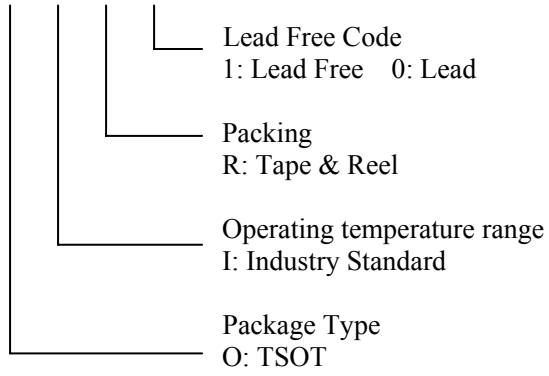

Figure 2.

Ordering Information

Order Number	Package Type	Marking	Operating Temperature Range
EUP2410OIR1	TSOT23-5	n0XXXX	-40 °C to +85°C

EUP2410



Absolute Maximum Ratings

FB, OUT, EN to GND -----	-0.3V to 6V
SW Current (Note 1) -----	-1.6A to +1.6A
Supply Voltage V_{IN} -----	2.2V to 6V
Output Voltage V_{OUT} -----	2.5V to 6V
Operating Temperature Rang -----	-40°C to +85°C
Storage Temperature Rang, T_{stg} -----	-65°C to +150°C
Thermal Resistance	
θ_{JA} (TSOT) -----	220°C/W

Note 1: SW has internal clamp diodes between GND-SW and SW-OUT. Applications that forward bias these diodes should take care not to exceed the IC's package power dissipation limits.

Electrical Characteristics

$V_{IN} = 2.4V$, $V_{OUT} = 3.5V$, $C_{IN} = 10\mu F$, $C_{OUT} = 10\mu F$, $L1 = 4.7\mu H$, $R1 = 178K\Omega$, $R2 = 100K\Omega$, $T_A = -40^\circ C$ to $+85^\circ C$, unless otherwise noted. Typical values are at $T_A = +25^\circ C$.)

Parameter	Conditions	EUP2410			Unit
		Min	Typ	Max.	
Supply Voltage		2.2		5	V
Output Voltage Range		2.5		6	V
Supply Current (Shutdown)	$V_{EN} = V_{OUT} = 0V$, $V_{SW} = 5V$		0.05	1	μA
Supply Current	$V_{FB} = 1.3V$		0.39		mA
Feedback Voltage		1.2	1.25	1.3	V
Feedback Input Current	$V_{FB} = 1.2V$		50		nA
Switching Frequency		310	500	690	KHz
Maximum Duty Cycle		80	85	90	%
EN Input Low Voltage				0.4	V
EN Input High Voltage		1.4			V
EN Pull Down Resistor			1		M Ω
Low-Side On Resistance	$V_{OUT} = 3.3V$ by design		450		m Ω
Low-Side Current Limit		1	1.6	2	A
High-Side On Resistance	$V_{OUT} = 3.3V$ by design		650		m Ω
Thermal Shutdown	Note 2		160		$^\circ C$
Thermal Shutdown Hysteresis	Note 2		30		$^\circ C$

Note 2: Guaranteed By Design .

Typical Operating Characteristics

Operating Conditions : $V_{IN} = 2.4V$, $V_{OUT} = 3.5V$, $C_{IN} = 10\mu F$, $C_{OUT} = 10\mu F$, $L1 = 4.7\mu H$, $R1 = 178K\Omega$, $R2 = 100K\Omega$

Efficiency vs Load Current

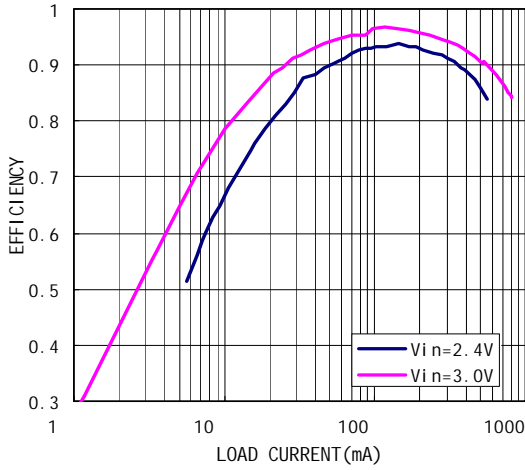

Load Regulation

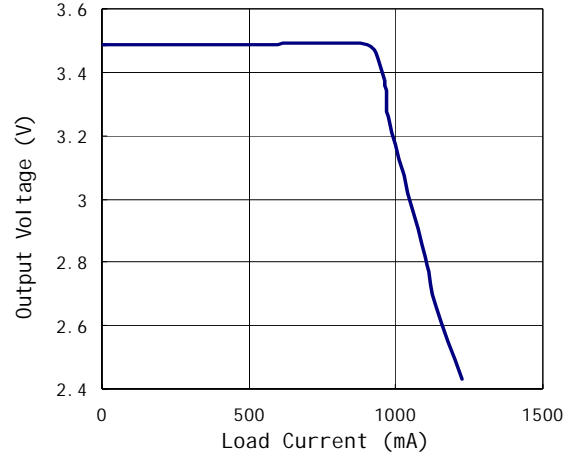

Line Regulation

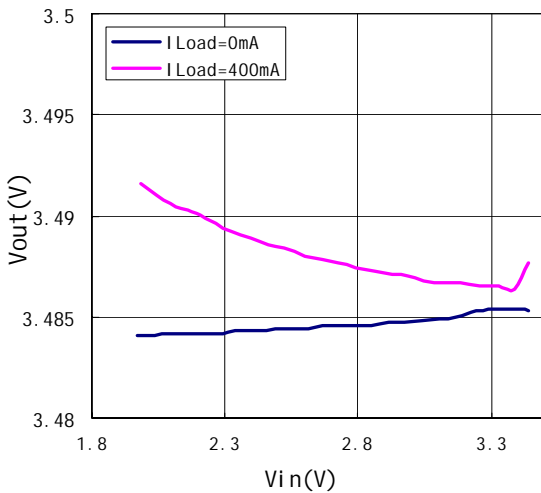

Continuous Mode Operation

$I_{LOAD} = 20mA$

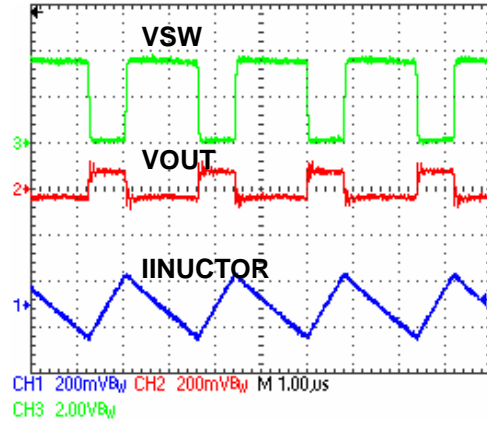

Continuous Mode Operation

$I_{LOAD} = 400mA$

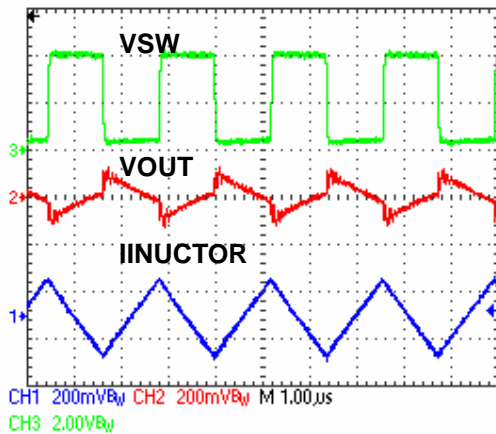

Transient Response

$I_{LOAD} = 40mA$ to $400mA$ Step

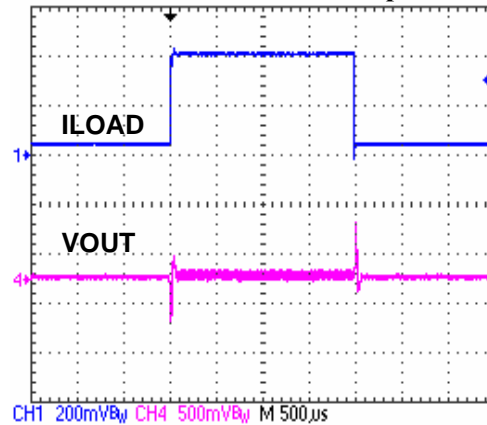

Typical Operating Characteristics (continued)

Operating Conditions : $V_{IN} = 2.4V$, $V_{OUT} = 3.5V$, $C_{IN} = 10\mu F$, $C_{OUT} = 10\mu F$, $L1 = 4.7\mu H$, $R1 = 178K\Omega$, $R2 = 100K\Omega$

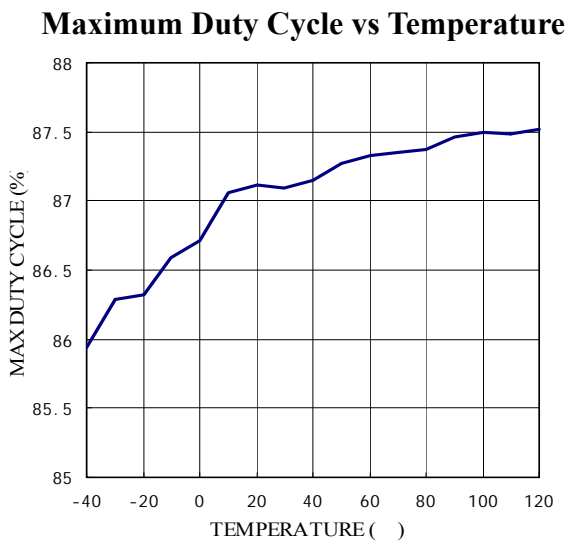
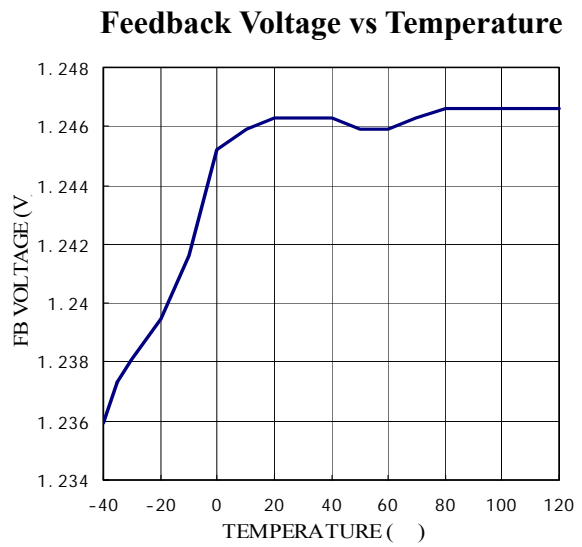
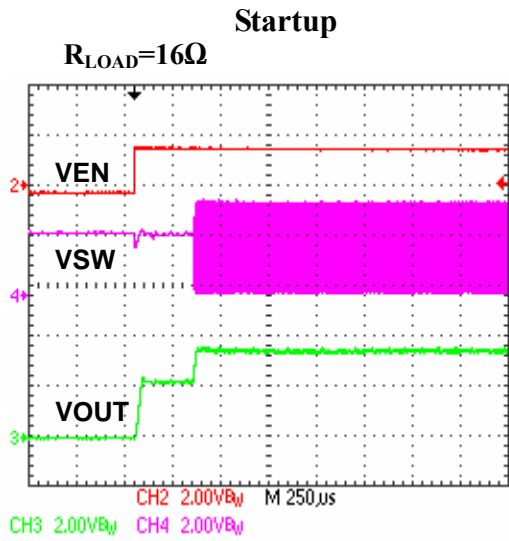

Operation

The EUP2410 uses a 500KHz fixed-frequency, current-mode regulation architecture to regulate the output voltage. The EUP2410 measures the output voltage through an external resistive voltage divider and compares that to the internal 1.25V reference to generate the error voltage. The current-mode regulator compares the error voltage to the inductor current to regulate the output voltage. The use of current-mode regulation improves transient response and control loop stability.

When the EUP2410 is disabled (EN = Low), both power switches are off. There is no current path from SW to OUT. Therefore, the output voltage discharges to ground. When the EUP2410 is enabled (EN = High), a limited start-current charges the output capacitor through the P-Channel MOSFET until the output voltage rising to SW, then the part operates in force PWM mode for regulating the output voltage to the target value.

At the beginning of each cycle, the N-Channel MOSFET switch is turned on, forcing the inductor current to rise. The current at the source of the switch is internally measured and converted to a voltage by the current sense amplifier. That voltage is compared to the error voltage. When the inductor current rises sufficiently, the PWM comparator turns off the switch, forcing the inductor current to the output capacitor through the internal P-Channel MOSFET rectifier, which forces the inductor current to decrease. The peak inductor current is controlled by the error voltage, which in turn is controlled by the output voltage. Thus the output voltage controls the inductor current to satisfy the load.

Soft-Start

The EUP2410 includes a soft-start timer that limits the voltage at the error amplifier output during startup to prevent excessive current at the input. This prevents premature termination of the source voltage at startup due to inrush current. This also limits the inductor current at startup, forcing the input current to rise slowly to the amount required to regulate the output voltage during soft-start.

Application Information

Component Selection

Setting the Output Voltage

Set the output voltage by selecting the resistive voltage divider ratio. The voltage divider drops the output voltage to the 1.25V feedback voltage. Use a 100kΩ resistor for R2 of the voltage divider. Determine the high-side resistor R1 by the equation:

$$R1 = \frac{V_{OUT} - V_{FB}}{\left(\frac{V_{FB}}{R2}\right)}$$

Where V_{OUT} is the output voltage, V_{FB} is the 1.25V feedback voltage and $R2=100k\Omega$.

Selecting the Input Capacitor

An input capacitor is required to supply the AC ripple current to the inductor, while limiting noise at the input source. Multi-layer ceramic capacitors are the best choice as they have extremely low ESR and are available in small footprints. Use an input capacitor value of 4.7μF or greater. This capacitor must be placed physically close to the device.

Selecting the Output Capacitor

A single 4.7μF to 10μF ceramic capacitor usually provides sufficient output capacitance for most applications. Larger values up to 22μF may be used to obtain extremely low output voltage ripple and improve transient response. The impedance of the ceramic capacitor at the switching frequency is dominated by the capacitance, and so the output voltage ripple is mostly independent of the ESR. The output voltage ripple V_{RIPPLE} is calculated as:

$$V_{RIPPLE} = \frac{I_{LOAD}(V_{OUT} - V_{IN})}{V_{OUT} \times C2 \times f_{SW}}$$

Where V_{IN} is the input voltage, I_{LOAD} is the load current, $C2$ is the capacitance of the output capacitor and f_{SW} is the 500KHz switching frequency.

Selecting the Inductor

The inductor is required to force the output voltage higher while being driven by the lower input voltage. A good rule for determining the inductance is to allow the peak-to-peak ripple current to be approximately 30%-50% of the maximum input current. Make sure that the peak inductor current is below the minimum current limit at the duty cycle used (to prevent loss of regulation due to the current limit variations).

Calculate the required inductance value L using the equations:

$$L = \frac{V_{IN} \times (V_{OUT} - V_{IN})}{V_{OUT} \times f_{sw} \times \Delta I}$$

$$I_{IN(MAX)} = \frac{V_{OUT} \times I_{LOAD(MAX)}}{V_{IN} \times \eta}$$

$$\Delta I = (30\% - 50\%) I_{IN(MAX)}$$

Where $I_{LOAD(MAX)}$ is the maximum load current, ΔI is the peak-to-peak inductor ripple current and η is efficiency. For the EUP2410, typically, $4.7\mu H$ is recommended for most applications. Choose an inductor that does not saturate at the peak switch current as calculated above with additional margin to cover heavy load transients and extreme startup conditions.

Layout Considerations

High frequency switching regulators require very careful layout for stable operation and low noise. All components must be placed as close to the IC as possible. All feedback components must be kept close to the FB pin to prevent noise injection on the FB pin trace. The ground return of C1 and C2 should be tied close to the GND pin. See the EUP2410 demo board layout for reference.

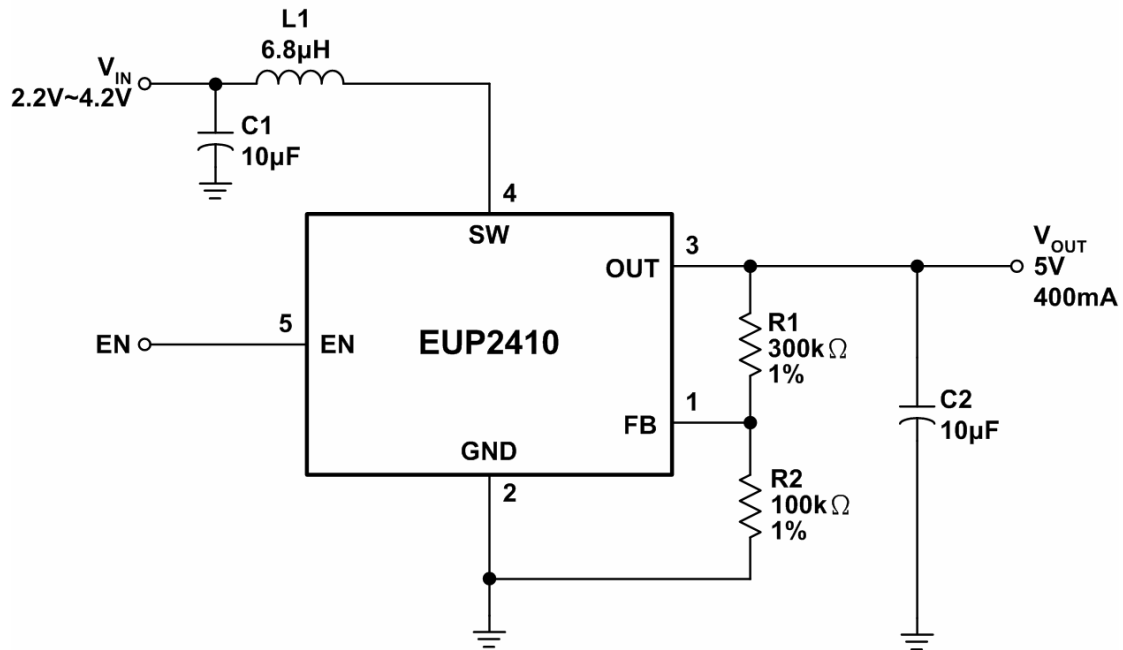
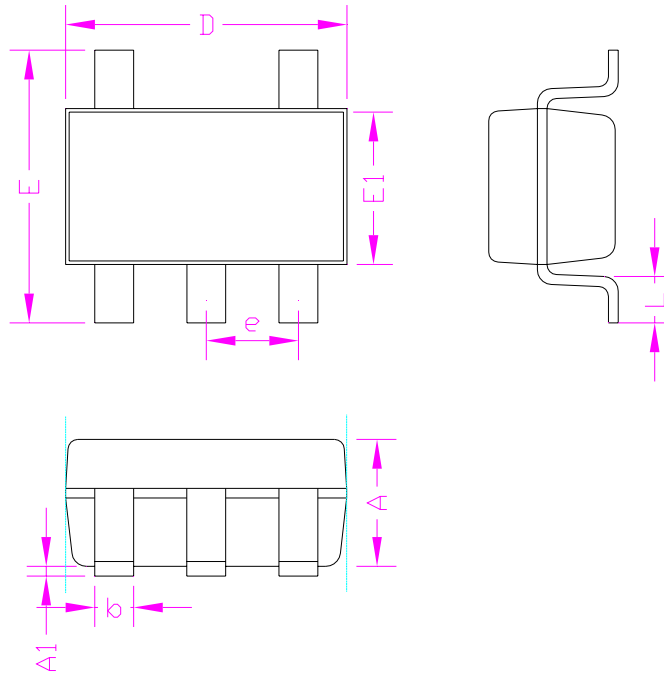

Figure 3. 5V Typical Application Circuit

Package Information

TSOT23-5



SYMBOLS	MILLIMETERS		INCHES	
	MIN.	MAX.	MIN.	MAX.
A	-	1.00	-	0.039
A1	0.00	0.15	0.000	0.006
D	2.90		0.114	
E1	1.60		0.063	
E	2.60	3.00	0.102	0.118
L	0.30	0.60	0.012	0.024
b	0.30	0.50	0.012	0.020
e	0.95		0.037	