

SGM41511

I²C Controlled 3A Single-Cell Battery Charger with High Input Voltage Capability and Narrow Voltage DC (NVDC) Power Path Management

FEATURES

- High Efficiency, 1.5MHz, Synchronous Buck Charger
 - ♦ 93% Charge Efficiency at 1A from 5V Input
 - ♦ 91% Charge Efficiency at 2A from 5V Input
 - ♦ Optimized for USB Voltage Input (5V)
 - ♦ Selectable PFM Mode for Light Load Efficiency
- USB On-The-Go (OTG) Support (Boost Mode)
 - ♦ Boost Converter with up to 1.2A Output
 - ♦ Boost Efficiency of 93.5% at 0.5A and 92.2% at 1A
 - ♦ Accurate Hiccup Mode Over-Current Protection
 - ♦ Soft-Start Capable with up to 500 μ F Capacitive Load
 - ♦ Output Short Circuit Protection
 - ♦ Selectable PFM Mode for Light Load Operations
- Single Input for USB or High Voltage Adapters
 - ♦ 3.9V to 13.5V Operating Input Voltage Range
 - ♦ 20V Absolute Maximum Input Voltage Rating
 - ♦ Programmable Input Current Limit and Dynamic Power Management (IINDPM, 100mA to 3.2A with 100mA Resolution) to Support USB 2.0 and USB 3.0 Standards and High Voltage Adapters
 - ♦ Maximum Power Tracking by Input Voltage Limit up to 5.4V (VINDPM)
 - ♦ VINDPM Tracking of Battery Voltage
- High Battery Discharge Efficiency with 28m Ω Switch
- Narrow Voltage DC (NVDC) Power Path Management
 - ♦ Instant-On with No or Highly Depleted Battery
 - ♦ Ideal Diode Operation in Battery Supplement Mode
- Ship Mode, Wake-Up and Full System Reset Capability by Battery FET Control
- Flexible Autonomous and I²C Operation Modes for Optimal System Performance

- Fully Integrated Switches, Current Sense and Compensation
- 10 μ A Ship Mode Low Battery Leakage Current
- High Accuracy
 - ♦ \pm 0.5% Charge Voltage Regulation
 - ♦ \pm 5% Charge Current Regulation at 1.5A
 - ♦ \pm 10% Input Current Regulation at 0.9A
- Safety
 - ♦ Battery Temperature Sensing (Charge/Boost Modes)
 - ♦ Thermal Regulation and Thermal Shutdown
 - ♦ Input Under-Voltage Lockout (UVLO)
 - ♦ Input Over-Voltage (ACOV) Protection

APPLICATIONS

Smart Phones, EPOS
Portable Internet Devices and Accessory

SIMPLIFIED SCHEMATIC

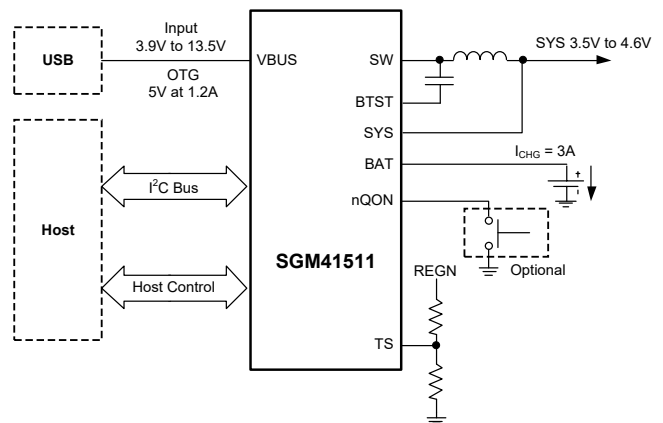

I²C Controlled 3A Single-Cell Battery Charger with High Input Voltage Capability and Narrow Voltage DC (NVDC) Power Path Management

SGM41511

GENERAL DESCRIPTION

The SGM41511 is a battery charger and system power path management device with integrated converter and power switches for use with single-cell Li-Ion or Li-polymer batteries. This highly integrated 3A device is capable for fast charging and supports a wide input voltage range suitable for smart phones, tablets and portable systems. I²C programming makes it a very flexible powering and charger design solution.

The device includes four main power switches: input reverse blocking FET (RBFET, Q1), high-side switching FET for buck or boost mode (HSFET, Q2), low-side switching FET for buck or boost mode switching (LSFET, Q3) and battery FET that controls the interconnection of the system and battery (BATFET, Q4). The bootstrap diode for the high-side gate driving is also integrated. The internal power path has a very low impedance that reduces the charging time and maximizes the battery discharge efficiency. Moreover the input voltage and current regulations provide maximum charging power delivery to the battery with various types of input sources.

A wide range of input sources are supported, including standard USB host, charging ports and USB compliant high voltage adapters. The default input current limit is automatically selected based on the built-in USB interface. This limit is determined by the detection circuit in the system (e.g. USB PHY). SGM41511 is USB 2.0 and USB 3.0 power specifications compliant with input current and voltage regulation. It also meets USB On-The-Go (OTG) power rating specification and is capable to boost the battery voltage to supply 5.15V on VBUS with 1.2A (or 0.5A) current limit.

The system voltage is regulated slightly above the battery voltage by the power path management circuit and is kept above the programmable minimum system voltage (3.5V by default). Therefore, system power is maintained even if the battery is completely depleted or removed. Dynamic power management (DPM) feature is also included that automatically reduces the charge current if the input current or voltage limit is reached. If the system load continues to increase after reduction of charge current down to zero, the power path management provides the deficit from battery by discharging battery to the system until the system power demand is fulfilled. This is called supplement mode and prevents input source overloading.

Starting and termination of a charging cycle can be accomplished without software control. The sensed battery voltage is used to decide for starting phase of charge in one of the three phases of charge cycle: pre-conditioning, constant current or constant voltage. When the charge current falls below a preset limit and the battery voltage is above recharge threshold, the charger function will automatically terminate and end the charging cycle. If the voltage of a charged battery falls below the recharge threshold, the charger starts another charging cycle.

Several safety features are provided in the SGM41511 such as over-voltage and over-current protections, battery temperature monitoring, charging safety timing, thermal shutdown and input UVLO. TS pin is connected to an NTC thermistor for battery temperature monitoring and protection in both charge and boost modes according to JEITA profile. This device also features thermal regulation in which the charge current is reduced if the junction temperature exceeds 80°C or 120°C (selectable).

Charging status is reported by the STAT output and fault/status bits. A negative pulse is sent to the nINT output pin as soon as a fault occurs to notify the host. BATFET reset control is provided by nQON pin to exit ship mode or for a full system reset.

The device is available in a Green TQFN-4x4-24L package.

PIN CONFIGURATION

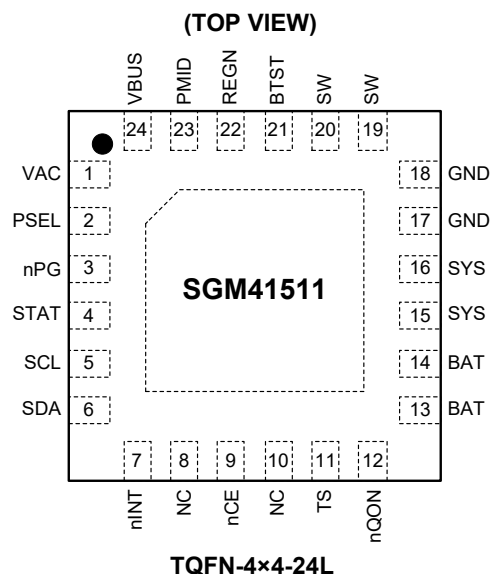

**I²C Controlled 3A Single-Cell Battery Charger with High Input Voltage
SGM41511 Capability and Narrow Voltage DC (NVDC) Power Path Management**

PACKAGE/ORDERING INFORMATION

MODEL	PACKAGE DESCRIPTION	SPECIFIED TEMPERATURE RANGE	ORDERING NUMBER	PACKAGE MARKING	PACKING OPTION
SGM41511	TQFN-4x4-24L	-40°C to +85°C	SGM41511YTQF24G/TR	SGM41511 YTQF24 XXXXX	Tape and Reel, 3000

MARKING INFORMATION

NOTE: XXXXX = Date Code, Trace Code and Vendor Code.

XXXXX

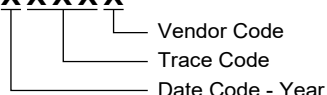

Green (RoHS & HSF): SG Micro Corp defines "Green" to mean Pb-Free (RoHS compatible) and free of halogen substances. If you have additional comments or questions, please contact your SGMICRO representative directly.

ABSOLUTE MAXIMUM RATINGS

Voltage Range (with Respect to GND)	
VAC, VBUS (Converter not Switching)	-2V to 20V ⁽¹⁾
BTST, PMID (Converter not Switching)	-0.3V to 20V
SW	-2V to 16V
SW (Peak for 10ns Duration)	-3V to 16V
BTST to SW	-0.3V to 6V
REGN, TS, nCE, nPG, BAT, SYS (Converter not Switching)	-0.3V to 6V
PSEL, SDA, SCL, nINT, nQON, STAT	-0.3V to 6V
Output Sink Current	
STAT	6mA (MAX)
nINT	6mA (MAX)
Package Thermal Resistance	
TQFN-4x4-24L, θ_{JA}	37°C/W
TQFN-4x4-24L, θ_{JC}	24°C/W
Junction Temperature	+150°C
Storage Temperature Range	-65°C to +150°C
Lead Temperature (Soldering, 10s)	+260°C
ESD Susceptibility	
HBM	4000V
CDM	1000V

NOTE: 1. Max 28V for 10 seconds.

OVERSTRESS CAUTION

Stresses beyond those listed in Absolute Maximum Ratings may cause permanent damage to the device. Exposure to absolute maximum rating conditions for extended periods may affect reliability. Functional operation of the device at any conditions beyond those indicated in the Recommended Operating Conditions section is not implied.

RECOMMENDED OPERATING CONDITIONS

Input Voltage Range, V_{VBUS}	3.9V to 13.5V
Input Current (VBUS), I_{IN}	3.25A (MAX)
Output DC Current (SW), I_{SWOP}	3.25A (MAX)
Battery Voltage, V_{BATOP}	4.624V (MAX)
Fast Charging Current, I_{BATOP}	3A (MAX)
Discharging Current (Continuous), I_{BATOP}	6A (MAX)
Operating Temperature Range	-40°C to +85°C

ESD SENSITIVITY CAUTION

This integrated circuit can be damaged by ESD if you don't pay attention to ESD protection. SGMICRO recommends that all integrated circuits be handled with appropriate precautions. Failure to observe proper handling and installation procedures can cause damage. ESD damage can range from subtle performance degradation to complete device failure. Precision integrated circuits may be more susceptible to damage because very small parametric changes could cause the device not to meet its published specifications.

DISCLAIMER

SG Micro Corp reserves the right to make any change in circuit design, or specifications without prior notice.

I²C Controlled 3A Single-Cell Battery Charger with High Input Voltage Capability and Narrow Voltage DC (NVDC) Power Path Management

SGM41511

PIN DESCRIPTION

PIN	NAME	TYPE ⁽¹⁾	FUNCTION
1	VAC	AI	Sense Input for DC Input Voltage (Typically from an AC/DC Adaptor). Must be connected to VBUS pin.
2	PSEL	DI	Power Source Selection Input. If PSEL is pulled high, the input current limit is set to 500mA (USB 2.0) and if it is pulled low, the limit is set to 2.4A (adaptor). When the I ² C link to the host is established, the host can program a different input current limit value by writing to the IINDPM[4:0] register.
3	nPG	DO	Open-Drain Active Low Input Power Good Indicator. Use a 10kΩ pull up to the logic high rail. A low state indicates a good input ($UVLO < V_{VBUS} < ACOV$, and above sleep mode threshold, $I_{LIM} > 30mA$).
4	STAT	DO	Open-Drain Charge Status Output. Use a 10kΩ pull up to the logic high rail (or an LED + a resistor). The STAT pin acts as follows: During charge: low (LED ON). Charge completed or charger in sleep mode: high (LED OFF). Charge suspend (in response to a fault): 1Hz, 50% duty cycle pulses (LED BLINKS). The function can be disabled via EN_ICHG_MON[1:0] register.
5	SCL	DI	I ² C Clock Signal. Use a 10kΩ pull up to the logic high rail.
6	SDA	DIO	I ² C Data Signal. Use a 10kΩ pull up to the logic high rail.
7	nINT	DO	Open-Drain Interrupt Output Pin. Use a 10kΩ pull up to the logic high rail. The nINT pin is active low and sends a negative 256μs pulse to inform host about a new charger status update or a fault.
8, 10	NC	—	Do Not Connect and Leave This Pin Float.
9	nCE	DI	Charge Enable Input Pin (Active Low). Battery charging is enabled when CHG_CONFIG bit is 1 and nCE pin is pulled low.
11	TS	AI	Temperature Qualification Voltage Input (Supports JEITA Profile). Connect to the battery NTC thermistor that is grounded on the other side. To program operating temperature window, it can be biased by a resistor divider between REGN and GND. Charge suspends if TS voltage goes out of the programmed range. It is recommended to use a 103AT-2 type thermistor. If NTC and TS pin function is not needed, use a 10kΩ/10kΩ pair for the resistor divider.
12	nQON	DI	BATFET Enable/Reset Control Input. Uses an internal pull-up to a small voltage for maintaining the default high logic (whenever a source or battery is available). In the ship mode the BATFET is off. To exit ship mode and turn BATFET on, a logic low pulse with a duration of $t_{SHIPMODE}$ (1s TYP) can be applied to nQON. When VBUS source is not connected, a logic low pulse with a duration of t_{QON_RST} (16s TYP) resets the system power (SYS) by turning BATFET off for t_{BATFET_RST} (250ms TYP) and then back on to provide a full power reset for system.
13, 14	BAT	P	Battery Positive Terminal Pin. Use a 10μF capacitor between BAT and GND pins close to the device. SYS and BAT pins are internally connected by BATFET with current sensing capability.
15, 16	SYS	P	Connection Point to Converter Output. SYS connects to the converter LC filter output that powers the system. BAT to SYS internal current (power from battery to system) is sensed. Connect a 20μF capacitor between SYS pin and GND close to the device (in addition to C_{OUT}).
17, 18	GND	—	Ground Pin of the Device.
19, 20	SW	P	Switching Node Output. Connect SW pin to the output inductor. Connect a 47nF bootstrap capacitor from SW pin to BTST pin.
21	BTST	P	High-side Driver Positive Supply. It is internally connected to the boost-strap diode cathode. Use a 47nF ceramic capacitor from SW pin to BTST pin.
22	REGN	P	LDO Output that Powers LSFET Driver and Internal Circuits. Internally, the REGN pin is connected to the anode of the bootstrap diode. Connect a 4.7μF (10V rating) ceramic capacitor from REGN pin to GND. The capacitor should be placed close to the IC. The output is typically 4.5V to 5V.
23	PMID	DO	PMID Pin. PMID is the actual higher voltage port of converter (buck or boost) and is connected to the drain of the reverse blocking MOSFET (RBFET) and the drain of HSFET. Connect a 10μF ceramic capacitor from PMID pin to GND. It is the proper point for decoupling of high frequency switching currents.
24	VBUS	P	Charger Input (V_{IN}). The internal N-channel reverse blocking MOSFET (RBFET) is connected between VBUS and PMID pins. Place a 1μF ceramic capacitor from VBUS pin to GND close to the device.
Exposed Pad	—	P	Thermal Pad and Ground Reference. It is the ground reference for the device and also the thermal pad to conduct heat from the device (not suitable for high current return). Tie externally to the PCB ground plane (GND). Thermal vias under the pad are needed to conduct the heat to the PCB ground planes.

NOTE:

1. AI = Analog Input, AO = Analog Output, AIO = Analog Input and Output, DI = Digital Input, DO = Digital Output, DIO = Digital Input and Output, P = Power.

I²C Controlled 3A Single-Cell Battery Charger with High Input Voltage Capability and Narrow Voltage DC (NVDC) Power Path Management

SGM41511

ELECTRICAL CHARACTERISTICS

($V_{VAC_UVLOZ} < V_{VAC} < V_{VAC_OV}$ and $V_{VAC} > V_{BAT} + V_{SLEEP}$, Full = -40°C to +85°C, typical values are at $T_J = +25^\circ\text{C}$, unless otherwise noted.)

PARAMETER	SYMBOL	CONDITIONS	TEMP	MIN	TYP	MAX	UNITS
Quiescent Currents							
Battery Discharge Current (BAT, SW, SYS) in Buck Mode	I_{BQ_VBUS}	$V_{BAT} = 4.5V$, $V_{VBUS} < V_{VAC_UVLOZ}$, leakage between BAT and VBUS, BATFET off	Full		0.1	1	μA
Battery Discharge Current (BAT) in Buck Mode	$I_{BQ_HIZ_BOFF}$	$V_{BAT} = 4.5V$, HIZ mode and BATFET_DIS = 1 or no VBUS, I ² C disabled, BATFET disabled	Full		10	20	μA
Battery Discharge Current (BAT, SW, SYS)	$I_{BQ_HIZ_BON}$	$V_{BAT} = 4.5V$, HIZ mode and BATFET_DIS = 0 or no VBUS, I ² C disabled, BATFET enabled	Full		20	40	μA
Input Supply Current (VBUS) in Buck Mode	I_{VBUS_HIZ}	$V_{VBUS} = 5V$, HIZ mode and BATFET_DIS = 1, no battery	Full		25	40	μA
		$V_{VBUS} = 12V$, HIZ mode and BATFET_DIS = 1, no battery	Full		45	70	
	I_{VBUS}	$V_{VBUS} = 12V$, $V_{VBUS} > V_{BAT}$, converter not switching	Full		1.3	2	mA
		$V_{BAT} = 3.8V$, $I_{SYS} = 0A$, $V_{VBUS} > V_{BAT}$, $V_{VBUS} > V_{VAC_UVLOZ}$, converter switching, BATFET off	+25°C		4		
Battery Discharge Current in Boost Mode	I_{BOOST}	$V_{BAT} = 4.2V$, $I_{VBUS} = 0A$, converter switching	+25°C		3		mA
BAT Pin, VAC Pin and VBUS Pin Power-Up							
VBUS Operating Range	V_{VBUS_OP}	V_{VBUS} rising	Full	3.9		13.5	V
VBUS UVLO to Have Active I ² C (with No Battery) Seen by Sense VAC Pin	V_{VAC_UVLOZ}	V_{VAC} rising	+25°C		3.25	3.8	V
I ² C Active Hysteresis	$V_{VAC_UVLOZ_HYS}$	V_{VAC} falling from above V_{VAC_UVLOZ}	+25°C		50		mV
V_{VAC} Minimum (as One of the Conditions) to Turn On REGN	$V_{VAC_PRESENT}$	V_{VAC} rising	+25°C		3.25	3.8	V
V_{VAC} Hysteresis (as One of the Conditions) to Turn On REGN	$V_{VAC_PRESENT_HYS}$	V_{VAC} falling	+25°C		50		mV
Sleep Mode Falling Threshold	V_{SLEEP}	$(V_{VAC} - V_{BAT})$, $V_{VBUSMIN_FALL} \leq V_{BAT} \leq V_{REG}$, V_{VAC} falling	+25°C	15	70	125	mV
Sleep Mode Rising Threshold	V_{SLEEPZ}	$(V_{VAC} - V_{BAT})$, $V_{VBUSMIN_FALL} \leq V_{BAT} \leq V_{REG}$, V_{VAC} rising	+25°C	150	200	260	mV
VAC Over-Voltage Rising Threshold (6.5V Setting)	$V_{VAC_OV_RISE}$	V_{VAC} rising, OVP[1:0] = 01	Full	6.15	6.5	6.95	V
VAC Over-Voltage Rising Threshold (10.5V Setting)		V_{VAC} rising, OVP[1:0] = 10	Full	10.00	10.5	11.05	
VAC Over-Voltage Rising Threshold (14V Setting)		V_{VAC} rising, OVP[1:0] = 11	Full	13.2	14	14.55	
VAC 6.5V Over-Voltage Hysteresis	$V_{VAC_OV_HYS}$	V_{VAC} falling, OVP[1:0] = 01	+25°C		500		mV
VAC 10.5V Over-Voltage Hysteresis		V_{VAC} falling, OVP[1:0] = 10	+25°C		500		
VAC 14V Over-Voltage Hysteresis		V_{VAC} falling, OVP[1:0] = 11	+25°C		500		
BAT Voltage to Have Active I ² C, (No Source on VBUS)	V_{BAT_UVLOZ}	V_{BAT} rising	Full	2.65			V
BAT Depletion Threshold	$V_{BAT_DPL_FALL}$	V_{BAT} falling	Full	2	2.25	2.45	V
	$V_{BAT_DPL_RISE}$	V_{BAT} rising	Full	2.1	2.5	2.85	
BAT Depletion Rising Hysteresis	$V_{BAT_DPL_HYS}$	V_{BAT} rising	+25°C		250		mV
Bad Adapter Detection Current (Internal Current Sink)	I_{BAD_SRC}	Sink current from VBUS to GND	+25°C		30		mA
Bad Adapter Detection (VBUS Voltage Drop) Falling Threshold	$V_{VBUSMIN_FALL}$	V_{VBUS} falling	Full	3.35	3.5	3.65	V
Bad Adapter Detection (VBUS Voltage Drop) Hysteresis	$V_{VBUSMIN_HYS}$		+25°C		250		mV

I²C Controlled 3A Single-Cell Battery Charger with High Input Voltage Capability and Narrow Voltage DC (NVDC) Power Path Management

SGM41511

ELECTRICAL CHARACTERISTICS (continued)

($V_{VAC_UVLOZ} < V_{VAC} < V_{VAC_OV}$ and $V_{VAC} > V_{BAT} + V_{SLEEP}$, Full = -40°C to +85°C, typical values are at $T_J = +25^\circ\text{C}$, unless otherwise noted.)

PARAMETER	SYMBOL	CONDITIONS	TEMP	MIN	TYP	MAX	UNITS	
Power Path Management								
System Regulation Voltage	V_{SYS}	$I_{SYS} = 0A$, $V_{BAT} = 4.4V$, $V_{BAT} > V_{SYS_MIN}$, BATFET_DIS = 1	+25°C		$V_{BAT} + 50mV$		V	
Minimum DC System Voltage Output	V_{SYS_MIN}	$I_{SYS} = 0A$, $V_{BAT} < SYS_MIN[2:0] = 101$ (3.5V), BATFET_DIS = 1	Full	3.5	3.69		V	
Maximum DC System Voltage Output	V_{SYS_MAX}	$I_{SYS} = 0A$, $V_{BAT} \leq 4.4V$, $V_{BAT} > V_{SYS_MIN} = 3.5V$, BATFET_DIS = 1	Full	4.37	4.45	4.54	V	
Top Reverse Blocking MOSFET On-Resistance between VBUS and PMID - Q1	R_{ON_RBFET}		+25°C		41		mΩ	
Top Switching MOSFET On-Resistance between PMID and SW - Q2	R_{ON_HSFET}	$V_{REGN} = 5V$	+25°C		45		mΩ	
Bottom Switching MOSFET On-Resistance between SW and GND - Q3	R_{ON_LSFET}	$V_{REGN} = 5V$	+25°C		55		mΩ	
BATFET forward Voltage in Supplement Mode	V_{FWD}		+25°C		30		mV	
Battery Charger								
Charge Voltage Program Range	$V_{BAT_REG_RANGE}$		Full	3.856		4.624	V	
Charge Voltage Step	$V_{BAT_REG_STEP}$		+25°C		32		mV	
Charge Voltage Setting	V_{BAT_REG}	$VREG[4:0] = 01011$ (4.208V)	+25°C	4.192	4.208	4.224	V	
			Full	4.184	4.208	4.232		
		$VREG[4:0] = 01111$ (4.352V)	+25°C	4.332	4.349	4.366		
			Full	4.323	4.349	4.375		
Charge Voltage Setting Accuracy	$V_{BAT_REG_ACC}$	$V_{BAT_REG} = 4.208V$ or $V_{BAT_REG} = 4.352V$	+25°C	-0.4		0.4	%	
Full	-0.6		0.6					
Charge Current Regulation Range	$I_{CHG_REG_RANGE}$		Full	0		3000	mA	
Charge Current Regulation Step	$I_{CHG_REG_STEP}$		+25°C		60		mA	
Charge Current Regulation Setting	I_{CHG_REG}	$V_{BAT} = 3.5V$	$I_{CHG} = 240mA$	+25°C	0.168	0.24	0.297	A
			$I_{CHG} = 720mA$	+25°C	0.609	0.720	0.768	
			$I_{CHG} = 1.38A$	+25°C	1.312	1.380	1.418	
Pre-Charge Current Regulation Setting	I_{PRECHG}	$IPRECHG[3:0] = 0010$ (180mA)	+25°C	130	175	222	mA	
Battery LOW Falling Threshold	V_{BATLOW_FALL}	$I_{CHG} = 480mA$	Full	2.83	2.95	3.05	V	
Battery LOW Rising Threshold	V_{BATLOW_RISE}	Change from pre-charge to fast charging	Full	3.06	3.15	3.22	V	
Termination Current Regulation Setting	I_{TERM}	$V_{BAT_REG} = 4.208V$, $ITERM[3:0] = 0010$ (180mA)	+25°C	142	180	218	mA	
Battery Short Voltage	V_{SHORT}	V_{BAT} falling	Full	2	2.05	2.1	V	
	V_{SHORTZ}	V_{BAT} rising	Full	2.15	2.2	2.25		
Battery Short Current	I_{SHORT}	$V_{BAT} < V_{SHORTZ}$	+25°C		80		mA	
Recharge Threshold below V_{BAT_REG}	V_{RECHG}	V_{BAT} falling, $VRECHG = 0$ (100mV)	Full	60	100	135	mV	
		V_{BAT} falling, $VRECHG = 1$ (200mV)	Full	155	195	235		
System Discharge Load Current	I_{SYS_LOAD}	$V_{SYS} = 4.2V$	+25°C		24		mA	
BATFET MOSFET On-Resistance	R_{ON_BATFET}	$V_{BAT} = 4.2V$, measured from BAT pin to SYS pin	+25°C		28	38	mΩ	

I²C Controlled 3A Single-Cell Battery Charger with High Input Voltage Capability and Narrow Voltage DC (NVDC) Power Path Management

SGM41511

ELECTRICAL CHARACTERISTICS (continued)

($V_{VAC_UVLOZ} < V_{VAC} < V_{VAC_OV}$ and $V_{VAC} > V_{BAT} + V_{SLEEP}$, Full = -40°C to +85°C, typical values are at $T_J = +25^\circ\text{C}$, unless otherwise noted.)

PARAMETER	SYMBOL	CONDITIONS	TEMP	MIN	TYP	MAX	UNITS
Input Voltage and Current Regulation (DPM: Dynamic Power Management)							
Input Voltage Regulation Limit	V_{INDPM}	$V_{INDPM}[3:0] = 0000$ (3.9V)	+25°C	3.76	3.87	3.98	V
Input Voltage Regulation Accuracy	V_{INDPM_ACC}		+25°C	-2.9		2.9	%
Input Voltage Regulation Limit	V_{INDPM}	$V_{INDPM}[3:0] = 0110$ (4.4V)	+25°C	4.24	4.36	4.48	V
Input Voltage Regulation Accuracy	V_{INDPM_ACC}		+25°C	-2.8		2.8	%
Input Voltage Regulation Limit Tracking VBAT	V_{DPM_VBAT}	$V_{BAT} = 4V$, $V_{INDPM} = 3.9V$, $V_{DPM_BAT_TRACK}[1:0] = 11$ (300mV)	+25°C	4.2	4.31	4.42	V
Input Voltage Regulation Accuracy Tracking VBAT	$V_{DPM_VBAT_ACC}$		+25°C	-2.6		2.6	%
USB Input Current Regulation Limit	I_{INDPM}	$V_{VBUS} = 5V$, current pulled from SW, $I_{INDPM}[4:0] = 00100$ (500mA)	+25°C	460		520	mA
		$V_{VBUS} = 5V$, current pulled from SW, $I_{INDPM}[4:0] = 01000$ (900mA)	+25°C	800		950	
		$V_{VBUS} = 5V$, current pulled from SW, $I_{INDPM}[4:0] = 01110$ (1.5A)	+25°C	1260		1570	
Input Current Limit during System Start-Up Sequence	I_{IN_START}		+25°C		200		mA
BAT Pin Over-Voltage Protection							
Battery Over-Voltage Threshold	V_{BATOV_RISE}	V_{BAT} rising, as percentage of V_{BAT_REG}	+25°C	103	104	105.5	%
	V_{BATOV_FALL}	V_{BAT} falling, as percentage of V_{BAT_REG}	+25°C	101	102	103	
Thermal Regulation and Thermal Shutdown							
Junction Temperature Regulation Threshold	$T_{JUNCTION_REG}$	Temperature increasing, $T_{REG} = 1$ (120°C)	Full		120		°C
		Temperature increasing, $T_{REG} = 0$ (80°C)	Full		80		
Thermal Shutdown Rising Temperature	T_{SHUT}	Temperature increasing	Full		150		°C
Thermal Shutdown Hysteresis	T_{SHUT_HYS}		Full		20		°C
JEITA Thermistor Comparator (Buck Mode)							
T1 (0°C) Threshold Voltage on TS Pin	V_{T1}	Charge suspends if temperature T is below T1 ($T < T1$), as percentage of V_{REGN}	Full	72.6	73.2	73.9	%
Falling		As percentage of V_{REGN}	Full	71.0	71.6	72.1	
T2 (10°C) Threshold	V_{T2}	Charge sets to $I_{CHG}/2$ and 4.2V if $T1 < T < T2$, as percentage of V_{REGN}	Full	67.4	68	68.7	%
Falling		As percentage of V_{REGN}	Full	66.0	66.7	67.4	
T3 (45°C) Threshold	V_{T3}	Charge sets to normal (I_{CHG} and 4.05V) if $T2 < T < T3$, as percentage of V_{REGN}	Full	43.4	44.5	45.5	%
Falling		As percentage of V_{REGN}	Full	45.1	45.8	46.4	
T4 (60°C) Threshold	V_{T4}	Charge sets to (4.1V or VREG) if $T3 < T < T4$ and suspends if $T > T4$, as percentage of V_{REGN}	Full	33.5	34.1	34.8	%
Falling		As percentage of V_{REGN}	Full	34.8	35.4	36.1	

**I²C Controlled 3A Single-Cell Battery Charger with High Input Voltage
SGM41511 Capability and Narrow Voltage DC (NVDC) Power Path Management**

ELECTRICAL CHARACTERISTICS (continued)

($V_{VAC_UVLOZ} < V_{VAC} < V_{VAC_OV}$ and $V_{VAC} > V_{BAT} + V_{SLEEP}$, Full = -40°C to +85°C, typical values are at $T_J = +25^\circ\text{C}$, unless otherwise noted.)

PARAMETER	SYMBOL	CONDITIONS	TEMP	MIN	TYP	MAX	UNITS
Cold or Hot Thermistor Comparator (Boost Mode)							
Cold Temperature Threshold (TS Pin Voltage Rising Threshold)	V_{BCOLD}	As percentage of V_{REGN} (approx. -20°C w/ 103AT)	Full	79.4	80	80.7	%
TS Voltage Falling (Exit from Cold Range to Cool)		As percentage of V_{REGN}	Full	78.2	79	79.6	
Hot Temperature Threshold (TS Pin Voltage Falling Threshold)	V_{BHOT}	As percentage of V_{REGN} (approx. 60°C w/ 103AT)	Full	30.5	31.2	31.9	%
TS Voltage Rising (Exit Hot Range to Warm)		As percentage of V_{REGN}	Full	33.7	34.4	35.0	
Charge Over-Current Comparator (Cycle-By-Cycle)							
HSFET Cycle-by-Cycle Over-Current Threshold	I_{HSFET_OCP}		+25°C	4		6.2	A
System Overload Threshold	I_{BATFET_OCP}		+25°C	6			A
Charge Under-Current Comparator (Cycle-By-Cycle)							
LSFET Under-Current Falling Threshold	I_{LSFET_UCP}	Change rectifier from synchronous mode to non-synchronous mode	+25°C		160		mA
PWM							
PWM Switching Frequency	f_{SW}	Oscillator frequency, buck mode	+25°C	1400	1500	1600	kHz
		Oscillator frequency, boost mode	+25°C	1400	1500	1600	
Maximum PWM Duty Cycle ⁽¹⁾	D_{MAX}		+25°C		98		%
Boost Mode Operation							
Boost Mode Regulation Voltage	V_{OTG_REG}	$V_{BAT} = 3.8V$, $I_{PMID} = 0A$, BOOSTV[1:0] = 10 (5.15V)	Full	5.015	5.185	5.355	V
Boost Mode Regulation Voltage Accuracy	$V_{OTG_REG_ACC}$	$V_{BAT} = 3.8V$, $I_{PMID} = 0A$, BOOSTV[1:0] = 10 (5.15V)	Full	-3.3		3.3	%
Exit Boost Mode Due to Low Battery Voltage	V_{BATLOW_OTG}	V_{BAT} falling, MIN_BAT_SEL = 0	Full	2.85	2.95	3.05	V
		V_{BAT} rising, MIN_BAT_SEL = 0	Full	3.07	3.15	3.21	
		V_{BAT} falling, MIN_BAT_SEL = 1	Full	2.48	2.60	2.69	
		V_{BAT} rising, MIN_BAT_SEL = 1	Full	2.71	2.80	2.85	
OTG Mode Max Output Current	I_{OTG}	BOOST_LIM = 1 (1.2A)	+25°C	1.2	1.5	1.8	A
OTG Over-Voltage Threshold	V_{OTG_OVP}	Rising threshold	Full	5.89	6.015	6.14	V
HSFET Under-Current Falling Threshold	I_{OTG_HSZCP}	Change rectifier from synchronous mode to non-synchronous mode	+25°C		100		mA
REGN LDO							
REGN LDO Output Voltage	V_{REGN}	$V_{VBUS} = 9V$, $I_{REGN} = 40mA$	Full	4.75	5.00	5.25	V
		$V_{VBUS} = 5V$, $I_{REGN} = 20mA$	Full	4.35	4.65	4.95	
Logic I/O Pin Characteristics (nCE, PSEL, SCL, SDA and nINT)							
Input Low Threshold (nCE)	V_{IL}		Full			0.3	V
Input High Threshold (nCE)	V_{IH}		Full	1			V
Input Low Threshold (PSEL, SCL, SDA, nINT)	V_{IL}		Full			0.2	V
Input High Threshold (PSEL, SCL, SDA, nINT)	V_{IH}		Full	1			V
High-Level Leakage Current	I_{BIAS}	Pull up rail 1.8V	Full			1	μA
Logic I/O Pin Characteristics (nPG, STAT) – Open-Drain							
Low-Level Output Voltage	V_{OL}		Full			0.3	V

NOTE: 1. Specified by design. Not production tested.

**I²C Controlled 3A Single-Cell Battery Charger with High Input Voltage
SGM41511 Capability and Narrow Voltage DC (NVDC) Power Path Management**

TIMING REQUIREMENTS

PARAMETER	SYMBOL	CONDITIONS	TEMP	MIN	TYP	MAX	UNITS
V_{VBUS}/V_{BAT} Power-Up							
VBUS OVP Reaction Time	t _{ACOV}	V _{VBUS} rising above ACOV threshold to turn off Q2	+25°C		0.1		μs
Wait Window for Bad Adapter Detection	t _{BADSRC}		+25°C		30		ms
Battery Charger							
Deglitch Time for Charge Termination	t _{TERM_DGL}		+25°C		230		ms
Deglitch Time for Recharge	t _{RECHG_DGL}		+25°C		230		ms
System Over-Current Deglitch Time to Turn Off Q4	t _{SYSOVLD_DGL}		+25°C		112		μs
Battery Over-Voltage Deglitch Time to Disable Charge	t _{BATOV}		+25°C		1		μs
Typical Charge Safety Timer Range	t _{SAFETY}	CHG_TIMER = 1	+25°C	5.4	6	6.4	hr
Typical Top-Off Timer Range	t _{TOP_OFF}	TOP_OFF_TIMER[1:0] = 10 (30min)	+25°C	32	35	39	min
nQON Timing and Ship Mode Timing							
nQON Negative Pulse Low Pulse Width to Turn On BATFET and Exit Ship Mode	t _{SHIPMODE}		+25°C	0.9	1	1.2	s
nQON Low Time to Reset BATFET	t _{QON_RST}		+25°C	14	16	20	s
BATFET Off Time during Full System Reset	t _{BATFET_RST}		+25°C	200	250	300	ms
Wait Delay for Entering Ship Mode	t _{SM_DLY}		+25°C	7	8	10	s
Digital Clock and Watchdog Timer							
Watchdog Reset Time	t _{WDT}	WATCHDOG[1:0] = 01, REGN LDO disabled	+25°C		40		s
Digital Clock Frequency in Low Power	f _{LPDIG}	REGN LDO disabled	+25°C		31		kHz
Digital Clock Frequency	f _{DIG}	REGN LDO enabled	+25°C		500		kHz
I²C Interface							
SCL Clock Frequency	f _{SCL}		+25°C		400		kHz

TYPICAL PERFORMANCE CHARACTERISTICS

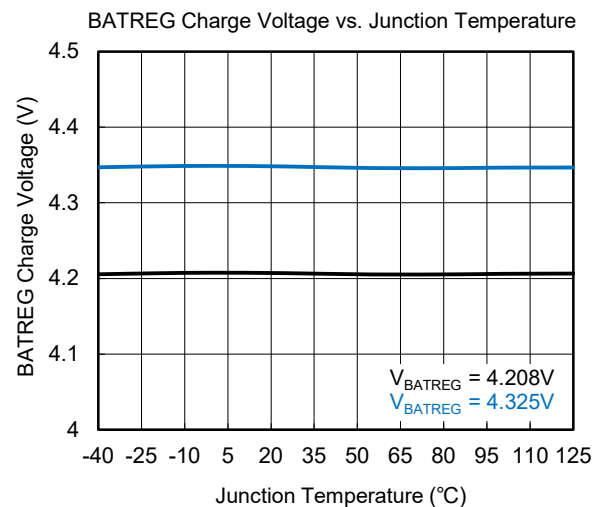
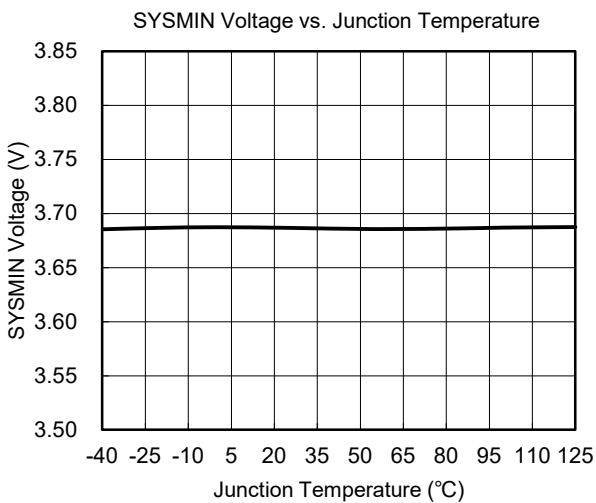
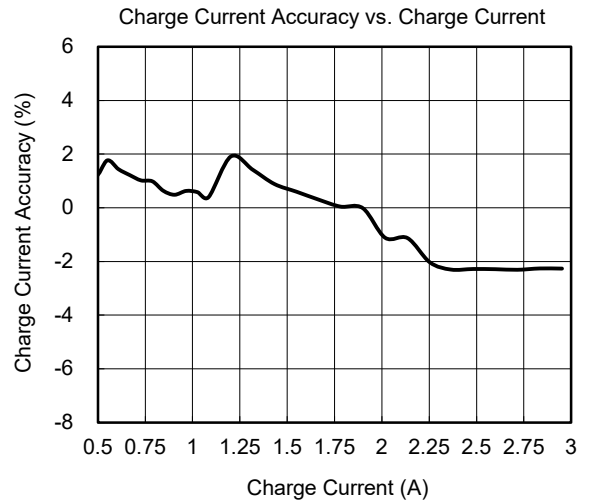
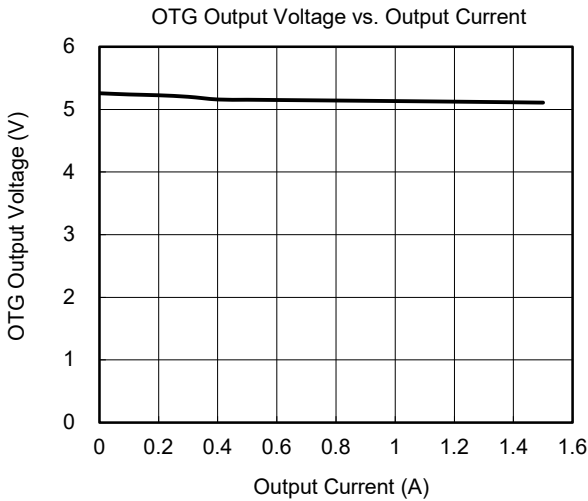
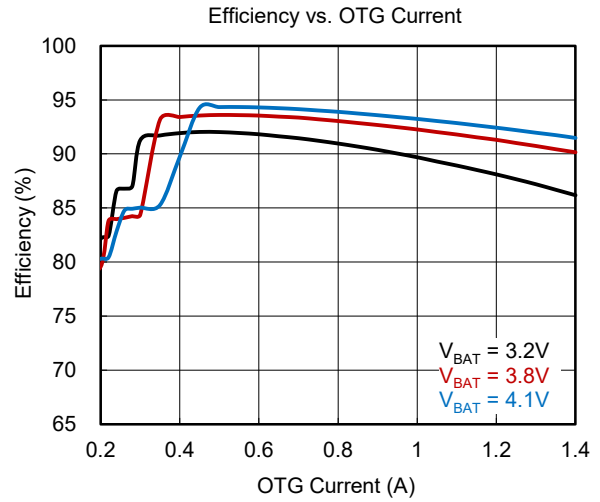
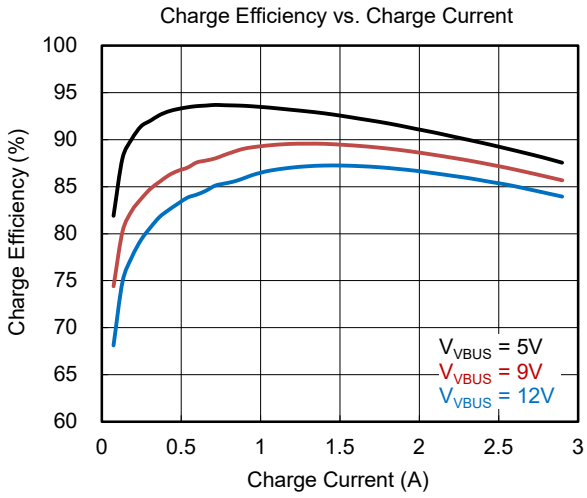

TYPICAL PERFORMANCE CHARACTERISTICS (continued)

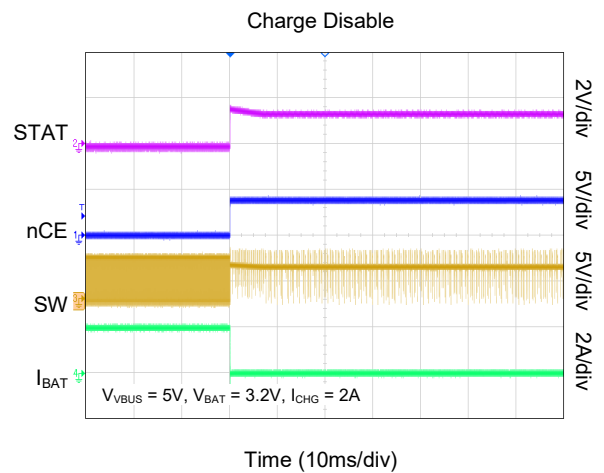
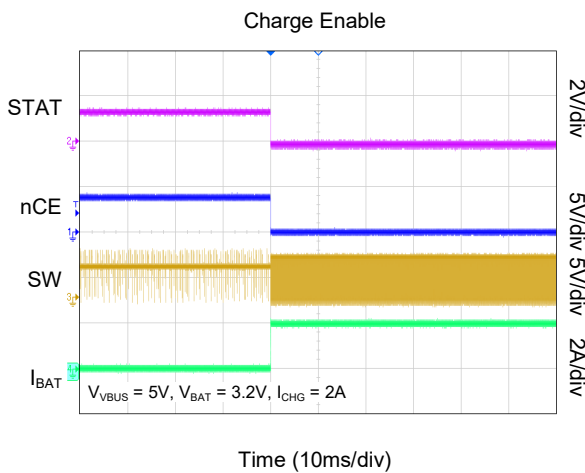
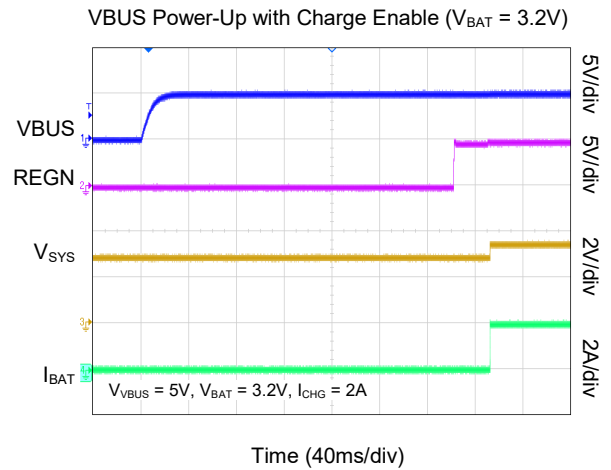
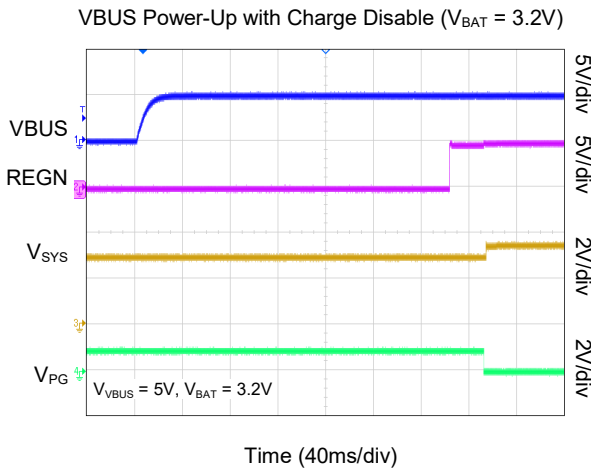
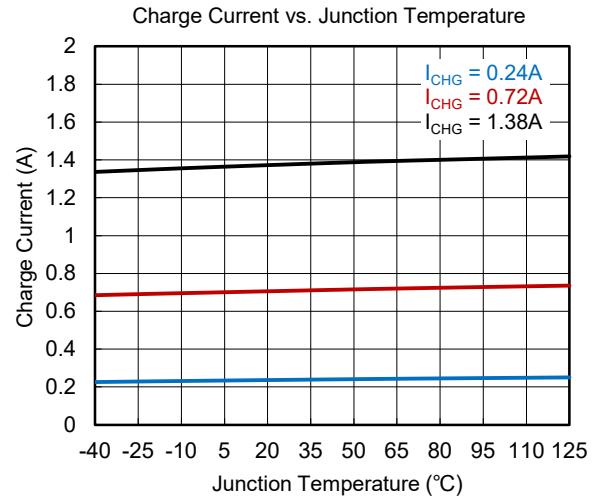
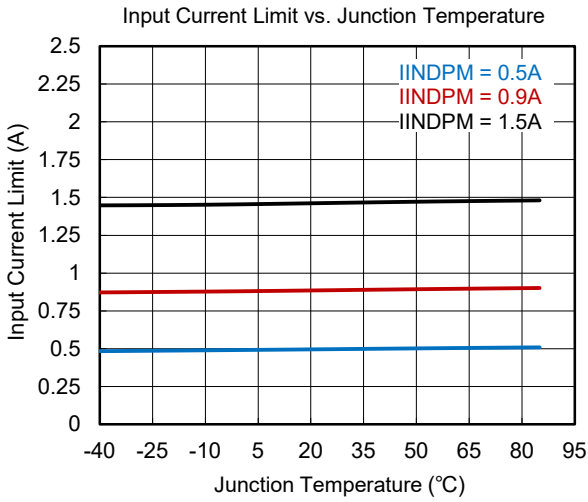

TYPICAL PERFORMANCE CHARACTERISTICS (continued)

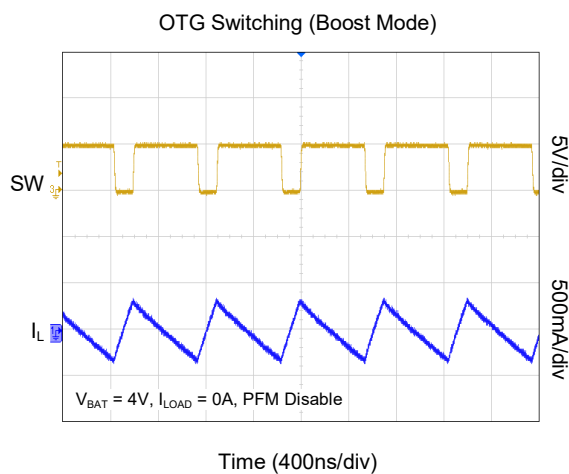
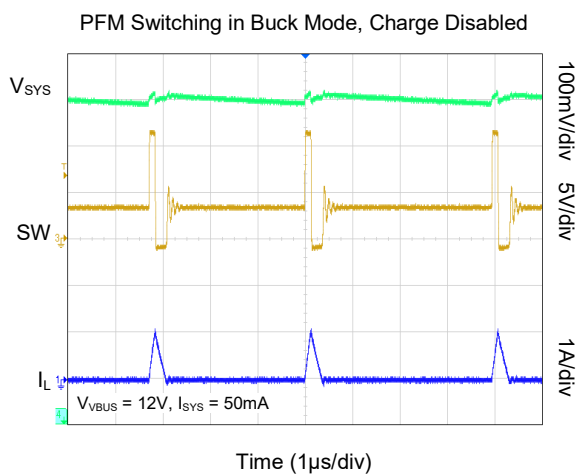
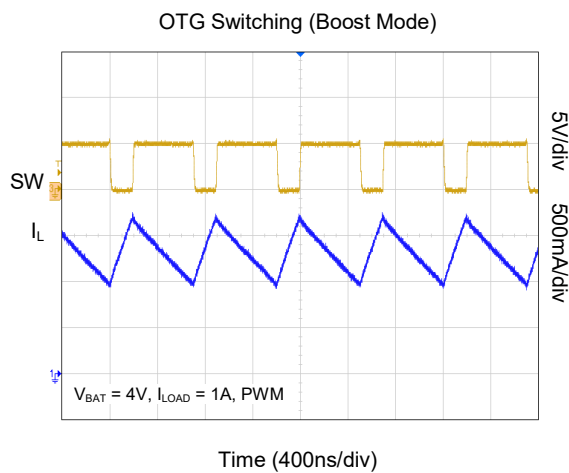
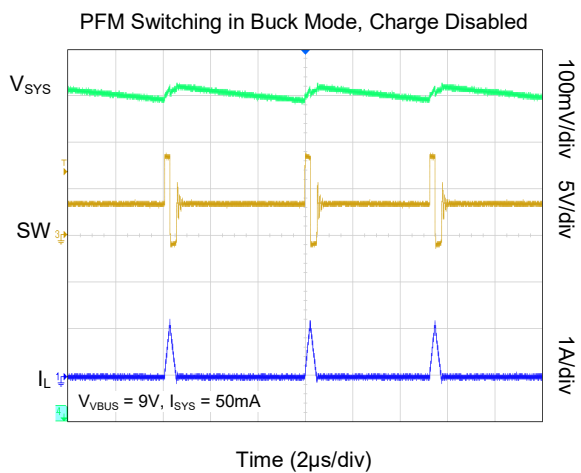
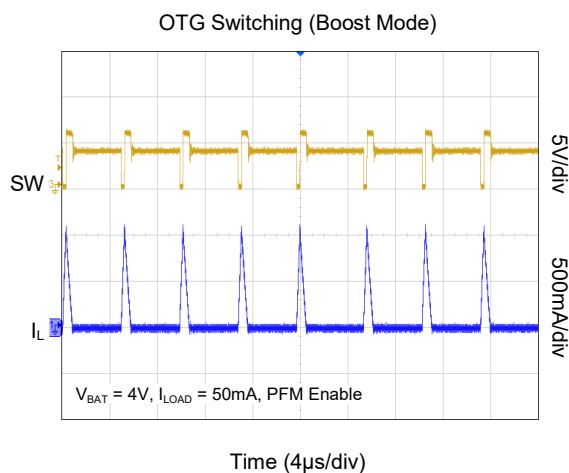
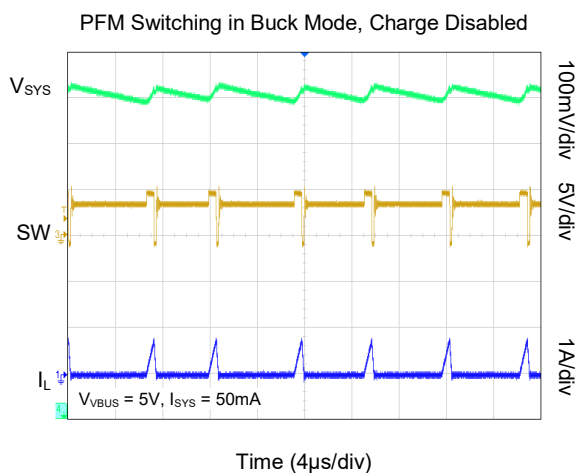

TYPICAL PERFORMANCE CHARACTERISTICS (continued)

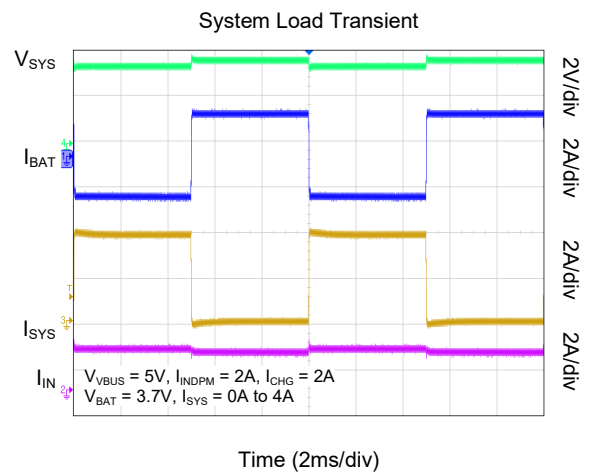
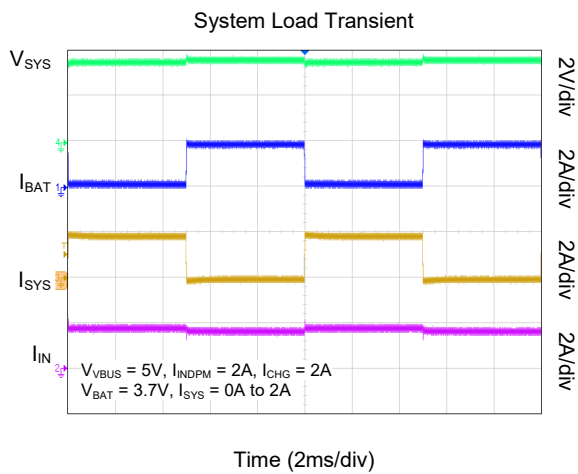
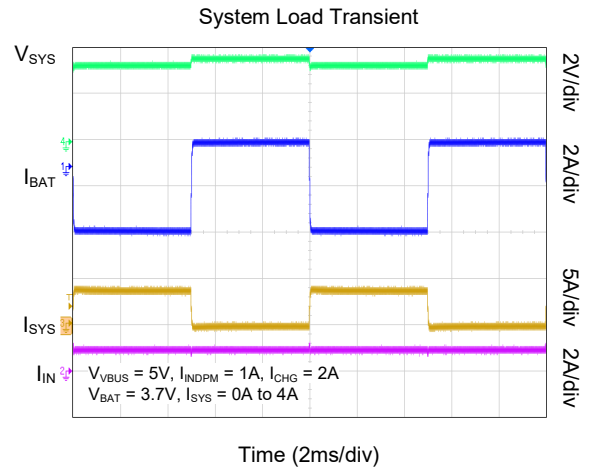
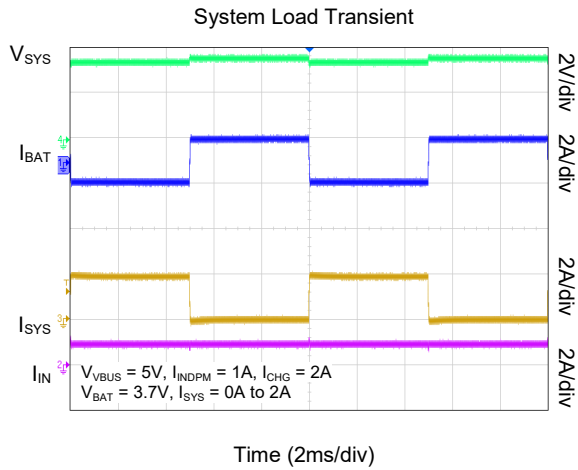
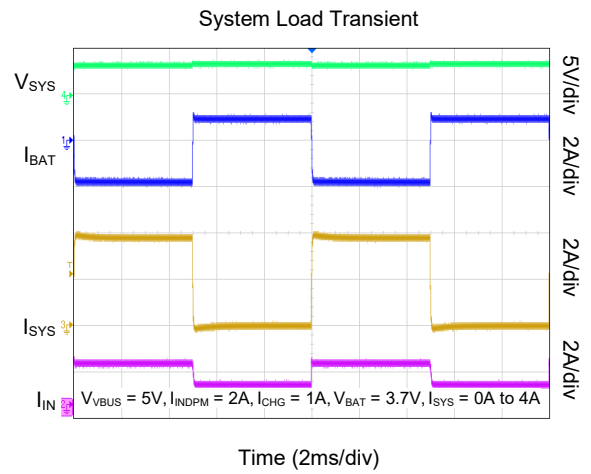
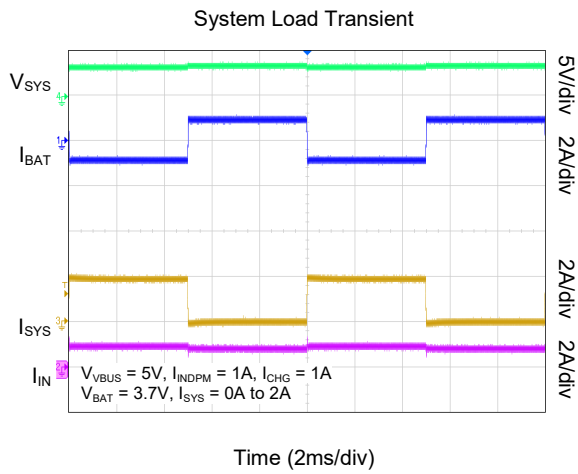

TYPICAL PERFORMANCE CHARACTERISTICS (continued)

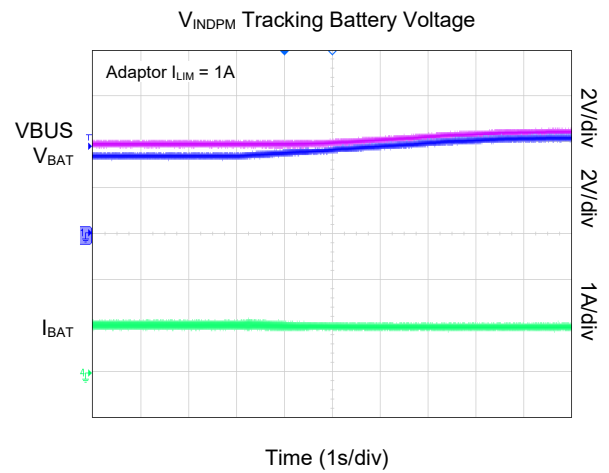
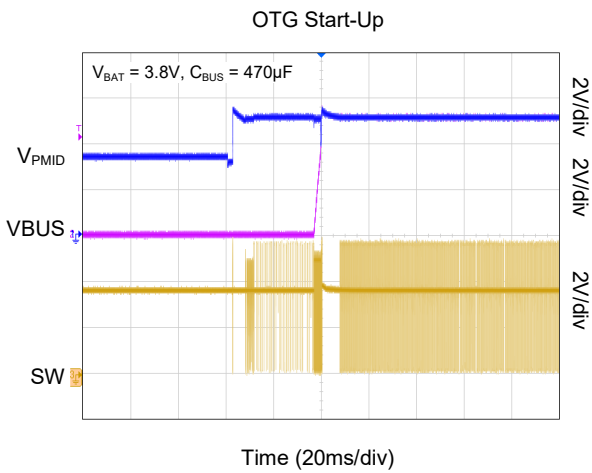
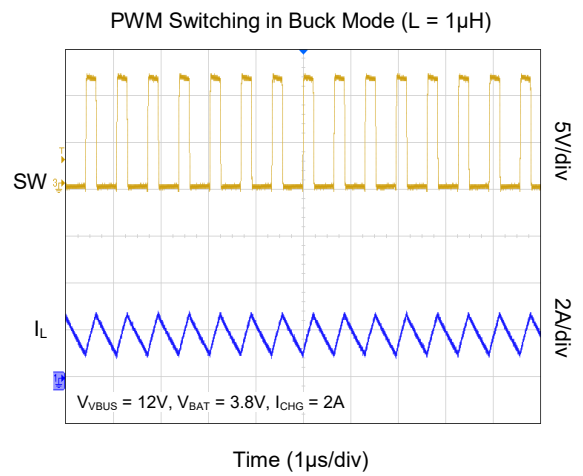
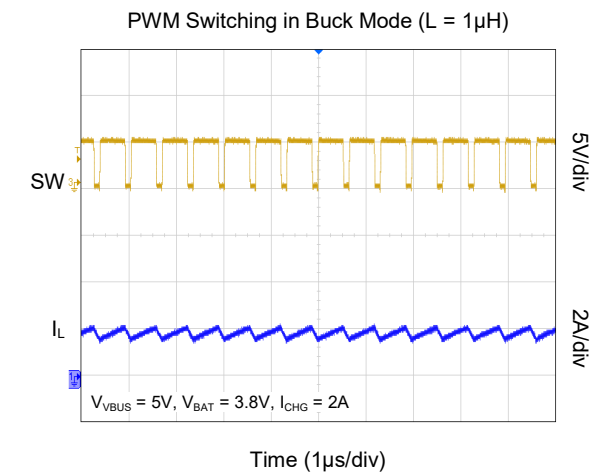

TYPICAL APPLICATION CIRCUIT

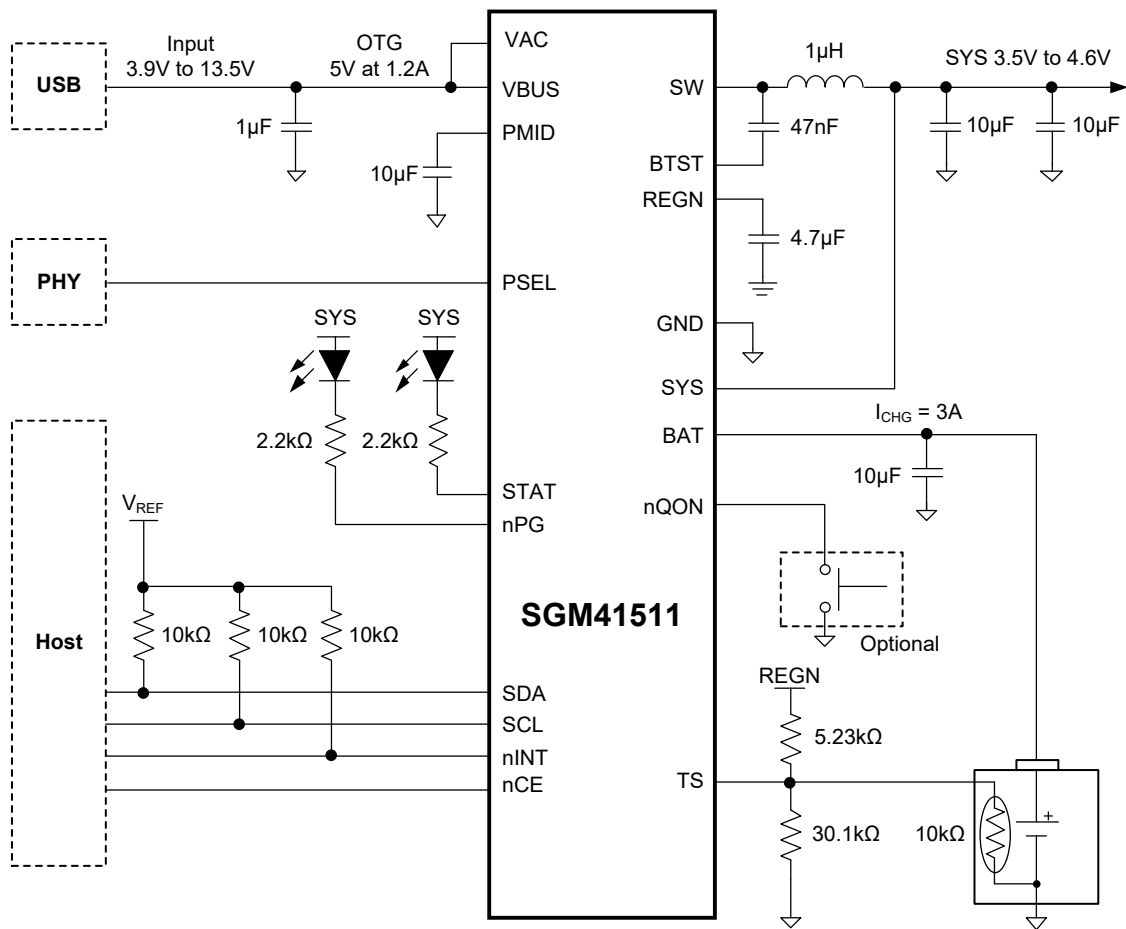

Figure 1. Typical Application Circuit

FUNCTIONAL BLOCK DIAGRAM

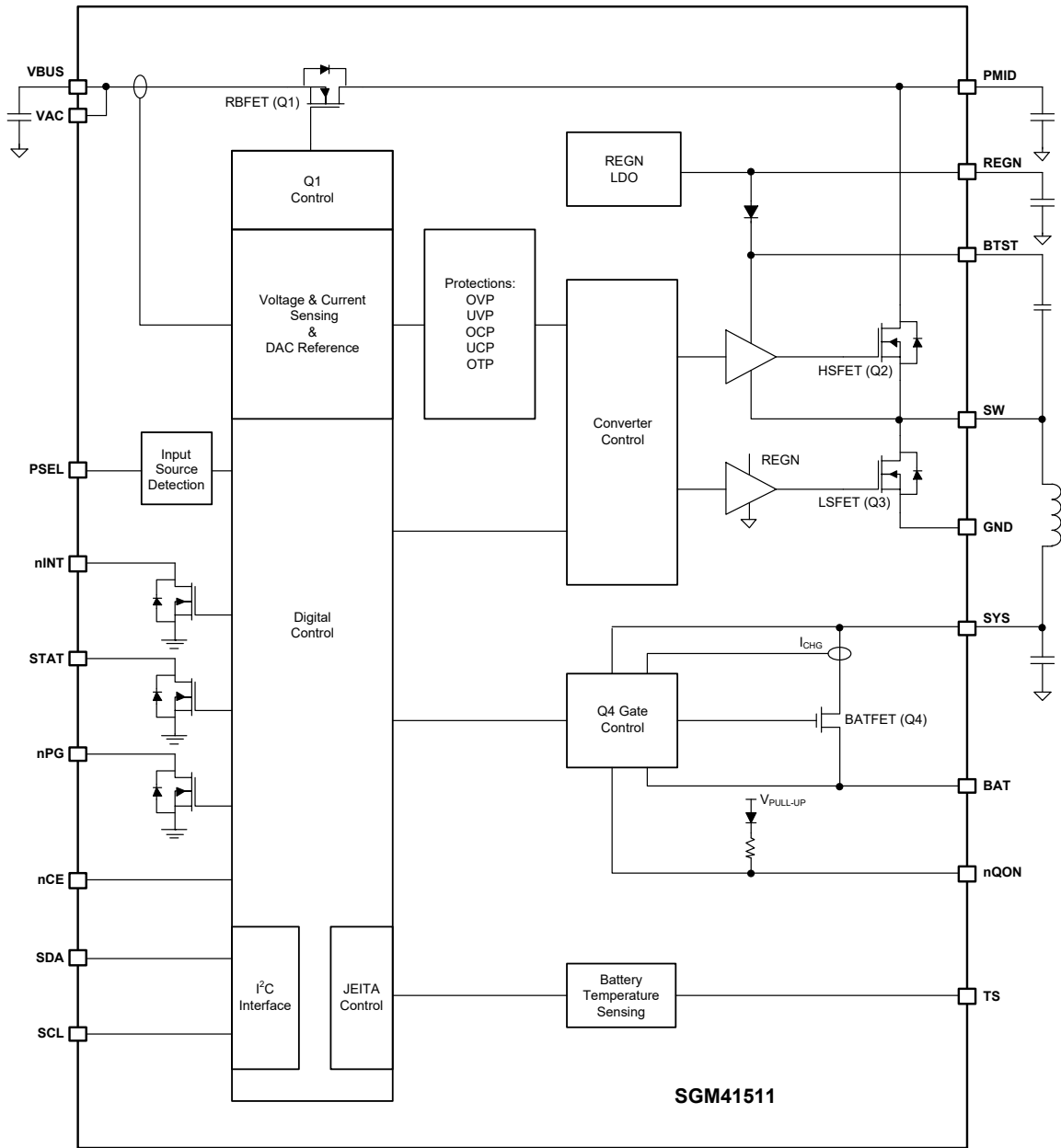

Figure 2. Block Diagram

DETAILED DESCRIPTION

The SGM41511 is a power management and charger device for application such as cell phones and tablets that use high capacity single-cell Li-Ion or Li-polymer batteries. The SGM41511 can accommodate a wide range of input sources including USB, wall adapter and car chargers. It is optimized for 5V input (USB voltage) but is capable to operate with input voltages from 3.9V up to 13.5V. It also supports JEITA profile for battery charging safety at high or low temperatures. Automatic power path selection to power the system (SYS) from the input source (VBUS), battery (BAT), or both, is another feature of the device. Battery charge current is programmable and can reach to a maximum of 3A (charge). In the boost mode the battery voltage is boosted to power the VBUS pin (1.2A MAX) when it is a power receiving node (USB OTG) that is typically regulated to 5.15V.

The device may operate in several different modes:

In HIZ mode, the VBUS and input source are disconnected from power circuit by turning the reverse blocking FET (Q1) off. In this mode, internal REGN LDO, converter switches and some other parts of the internal circuit remain off to save the battery while it is supplying DC power to the system through BATFET.

In the sleep mode the switching is stopped. The charger goes to the sleep mode when the input source voltage (V_{VAC}) is not high enough for charging the battery. In other words, V_{VAC} is smaller than $V_{BAT} + V_{SLEEP}$ (where V_{SLEEP} is a small threshold) and buck converter is not able to charge, even at its maximum duty cycle. The boost may also go to the sleep mode if similar issue happens in the reverse direction (when V_{VAC} is almost equal or smaller than V_{BAT}).

In supplement mode, the input source power is not enough to supply system demanded power and the battery assists by discharging to the system in parallel, providing the deficit.

Power-On-Reset (POR)

The internal circuit of the device is powered from the greater voltage between V_{VBUS} and V_{BAT} . When the voltage of the selected source goes above its UVLO level ($V_{VBUS} > V_{VBUS_UVLOZ}$ or $V_{BAT} > V_{BAT_UVLOZ}$) a POR happens and activates the sleep comparator, battery depletion comparator and BATFET driver. Upon activation, the I²C interface will also be ready for communication and all registers reset to their default values.

Power-Up from Battery Only (No Input Source)

When only the battery is present as a source and its voltage is above depletion threshold ($V_{BAT_DPL_RISE}$), the BATFET turns on and connects the battery to the system. The quiescent current is minimum because the REGN LDO remains off. Conduction losses are also low due to small R_{DSON} of BATFET. Low losses help extending the battery run time.

The discharge current through BATFET is continuously monitored. In the supplement mode, if a system overload (or short) occurs ($I_{BAT} > I_{BATFET_OCP}$), the BATFET is turned off immediately and BATFET_DIS bit is set to 1. The BATFET will not enable until the input source is applied or one of the **BATFET Enable Mode (Exit Ship Mode)** methods (explained later) is used to activate the BATFET.

Power-Up Process from the Input Source

Upon connection of an input source (VBUS), its voltage sensed from VAC pin is checked to turn on the internal REGN LDO regulator and the bias circuits (no matter if the battery is present or not). The input current limit is determined and set before the buck converter is started. The sequence of actions when VBUS as input source is powered up are:

1. **REGN LDO Power-up.**
2. **Poor source detection (qualification).**
3. **Input source type detection.** (Based on PSEL input. It is used to set the default input current limit (IINDPM[4:0]).)
4. **Setting of the input voltage limit threshold (VINDPM threshold).**
5. **DC/DC converter power-up.**

Details of the power-up steps are explained in the following sections.

DETAILED DESCRIPTION (continued)

REGN LDO Power-Up

The REGN low dropout regulator powers the internal bias circuits, HSFET and LSFET gate drivers and TS rail (thermistor pin). The STAT pin can also be pulled up to REGN. The REGN enables when the following 2 conditions are satisfied and remain valid for a 220ms delay time, otherwise the device stays in high impedance mode (HIZ) with REGN LDO off.

1. $V_{VAC} > V_{VAC_PRESENT}$.
2. $V_{VAC} > V_{BAT} + V_{SLEEPZ}$ (in buck mode) or $V_{VBUS} < V_{BAT} + V_{SLEEP}$ (in boost mode).

In HIZ state, the VBUS source is disconnected (reverse blocking FET or Q1 is turned off) and the quiescent current drawn from VBUS is very small (less than I_{VBUS_HIZ}). System is only powered by the battery in HIZ mode.

Poor Source Detection (Qualification)

When REGN LDO is powered, the input source (adaptor) is checked for its type and current capacity. To start the buck converter, the input (VBUS) must meet the following:

1. $V_{VBUS} < V_{VAC_OV}$.
2. $V_{VBUS} > V_{VBUS_MIN}$ during t_{BAD_SRC} test period (30ms TYP) in which the I_{BAD_SRC} (30mA TYP) current is pulled from VBUS.

If the test is failed, the conditions are repeatedly checked every two seconds. As soon as the input source passes qualification, the VBUS_GD bit in status register is set to 1 and a pulse is sent to the nINT pin to inform the host. Type detection will start as next step.

Input Source Type Detection

The input source detection will run through the PSEL pin while REGN LDO is powered and after the VBUS_GD bit is set. The input current limit of the SGM41511 is sets based on the state of PSEL pin. A pulse is sent to nINT pin to inform the host when the input source type detection is completed. Some registers and pins are also updated as detailed below:

1. Input current limit register (the value in the IINDPM[4:0]) is changed to set current limit.
2. PG_STAT (power good) bit is set.
3. VBUS_STAT[2:0] register is updated to indicate USB or adaptor input source types.

The input current is always limited by the IINDPM[4:0] register and the limit can be updated by the host if needed.

Input Current Limit by PSEL

PSEL pin interfaces with USB physical layer (PHY) for input current limit setting. The USB PHY device output is used to detect if the input is a USB host or a charging port. In the host-control mode, the host must enable IINDET_EN bit for reading the PSEL value and updating the IINDPM[4:0]. In the default mode, IINDPM[4:0] is updated automatically by PSEL value in real time as given in Table 1.

Setting of the Input Voltage Limit Threshold (VINDPM Threshold)

A wide voltage range (3.9V to 5.4V) is supported for the input voltage limit setting in VINDPM[3:0]. 4.5V is the default for USB.

The device supports dynamic tracking of the battery voltage (VINDPM). VDPM_BAT_TRACK[1:0] bits can be used to enable tracking (00 to disable tracking) and set the tracking offset value. When the tracking is enabled, the input voltage limit will be set to the larger value between the VINDPM[3:0] and $V_{BAT} + VDPM_BAT_TRACK[1:0]$. The VDPM_BAT_TRACK[1:0] tracking offset can be set to 200mV, 250mV or 300mV.

DC/DC Converter Power-Up

The 1.5MHz switching converter composed of LSFET and HSFET is enabled and can start switching when the input current limit is set. Converter is initiated with a soft start when the system voltage is ramped up. The input current is limited to 200mA or IINDPM[4:0], whichever is smaller, if SYS voltage is less than 2.2V, otherwise the limit is set to IINDPM[4:0].

The BATFET remains on to charge the battery if the battery charging function is enabled, otherwise BATFET turns off.

When converter operates for battery charging, it acts as an efficient, fixed frequency synchronous buck converter regardless of the input/output voltages and currents. However, it is capable to switch to PFM mode at light load when charging is disabled or when the detected battery voltage is less than minimum system voltage setting. PFM operation can be enabled or prevented in either buck or boost mode using the PFM_DIS bit.

Table 1. Input Current Limit Setting from PSEL

Input Detection	PSEL Pin	Input Current Limit (I_{LIM})	VBUS_STAT[2:0]
USB Host SDP	High	500mA	001
Adapter	Low	2400mA	010

DETAILED DESCRIPTION (continued)

Boost Mode

The SGM41511 supports USB On-The-Go. When a load device is connected to the USB port, the converter can operate as a step-up synchronous converter (boost mode) with 1.5MHz switching frequency to supply power from the battery to that load. The 500mA USB OTG output current limit requirement is applicable by programming, however the boost converter can deliver 1.2A to the output (default limit). Converter will set to boost mode if at least 30ms is passed from enabling this mode (OTG_CONFIG bit = 1) and the following conditions are satisfied:

1. $V_{BAT} > V_{BATLOW_OTG}$.
2. $V_{VBUS} < V_{BAT} + V_{SLEEP}$ (in sleep mode).
3. Voltage at TS (thermistor) pin is within acceptable range ($V_{BHOT} < V_{TS} < V_{BCOLD}$).

The output voltage is set to $V_{VBUS} = 5.15V$ and is maintained as long as V_{BAT} is above V_{BATLOW_OTG} . The output current can reach up to the programmed value by BOOST_LIM bit (0.5A or 1.2A). The VBUS_STAT[2:0] status register bits are set to 111 in boost mode (OTG).

To minimize the output overshoot in boost mode, the device starts with PFM first and then switches to PWM. As stated before, PFM can be avoided using PFM_DIS bit in buck and boost modes.

Host Mode and Default Mode Operation with the Watchdog Timer

After a power on reset, the device starts in default mode (standalone) with all registers reset as if the watchdog timer is

expired. When the host is in sleep mode or there is no host, the device stays in the default mode in which the SGM41511 operates like an autonomous charger. The battery is charged for 6 hours (default value for the fast charging safety timer). Then the charge stops while buck converter continues to operate to power the system load. In this mode the PSEL pin directly affects the IINDPM[4:0] register in real time and WATCHDOG_FAULT bit is high.

Most of the flexibility features of the SGM41511 become available in the host mode when the device is controlled by a host with I²C. By setting the WD_RST bit to 1, the charger mode changes from default mode to host mode. In this mode the WATCHDOG_FAULT bit is low and all device parameters can be programmed by the host. To prevent device watchdog reset that results in going back to default mode, the host must either disable the watchdog timer by setting WATCHDOG[1:0] = 00, or it must consistently reset the watchdog timer before expiry by writing 1 to WD_RST to prevent WATCHDOG_FAULT bit to be set. Every time a 1 is written to the WD_RST, the watchdog timer will restart counting. Therefore, it should be reset again before overflow (expiry) to keep the device in the host mode. If the watchdog timer expires (WATCHDOG_FAULT bit = 1), the device returns to default mode and all registers are reset to their default values except for IINDPM[4:0], VINDPM[3:0], BATFET_RST_EN, BATFET_DLY and BATFET_DIS bits that keep their values unchanged.

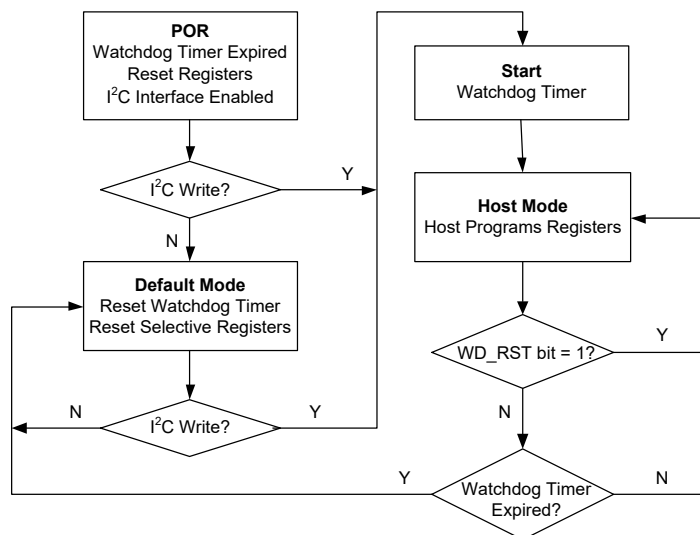

Figure 3. Watchdog Timer Flow Chart

DETAILED DESCRIPTION (continued)

Battery Charging Management

The SGM41511 is designed for charging single-cell Li-Ion or Li-poly batteries with a charge current up to 3A max. The battery connection switch (BATFET) is in the charge or discharge current path features low on-resistance (28mΩ) to allow high efficiency and low voltage drop.

Charging Cycle in Autonomous Mode

Charging is enabled if CHG_CONFIG = 1 and nCE pin is pulled low. In default mode, the SGM41511 runs a charge cycle with the default parameters itemized in Table 2. At any moment, the control can be taken by a host by changing to the host mode.

Table 2. Charging Parameter Default Setting

Default Mode	SGM41511
Charging Voltage (VREG)	4.208V
Charging Current (I _{CHG_REG})	2.04A
Pre-Charge Current (I _{PRECHG})	180mA
Termination Current (I _{TERM})	180mA
Temperature Profile	JEITA
Safety Timer	6 hours

Start a New Charging Cycle

If the converter can start switching and all the following conditions are satisfied a new charge cycle starts:

- NTC temperature fault is not asserted (TS pin).
- Safety timer fault is not asserted.
- BATFET is not forced off. (BATFET_DIS bit = 0).
- Charging enabled (3 conditions: CHG_CONFIG bit = 1, ICHG[5:0] register is not 0mA and nCE pin is low).
- Battery voltage is below the programmed full charge level (VREG).

A new charge cycle starts automatically if battery voltage falls below the recharge threshold level (VREG - 100mV or VREG - 200mV configured by VRECHG bit). Also, if the charge cycle is completed, a new charging cycle can be initiated by toggling of the nCE pin or CHG_CONFIG bit.

Normally a charge cycle terminates when the charge voltage is above the recharge threshold level and the charging current falls below the termination threshold if the device is

not in thermal regulation or Dynamic Power Management (DPM) mode.

Charge Status Report

STAT is an open-drain output pin that reports the status of charge and can drive an LED for indication: a low indicates charging is in progress, a high shows charging is completed or disabled and alternating low/high (blinking) shows a charging fault. The STAT may be disabled (keep the open drain switch off) by setting EN_ICHG_MON[1:0] = 11.

The CHRГ_STAT[1:0] status register reports the present charging phase and status by two bits: 00 = charging disabled, 01 = in pre-charge, 10 = in fast charging (constant current mode or constant voltage mode) and 11 = charging completed.

A negative pulse is sent on nINT pin to inform the host when a charging cycle is completed.

Battery Charging Profile

The SGM41511 features a full battery charging profile with five phases. In the beginning of the cycle the battery voltage (V_{BAT}) is tested, and appropriate current and voltage regulation levels are selected as shown in Table 3. Depending on the detected status of the battery, the proper phase is selected to start or for continuation of the charging cycle. The phases are: battery short (battery voltage too low), preconditioning, constant current, constant voltage and an optional top-off trickle charging phase.

Table 3. Charging Current Setting Based on V_{BAT}

V _{BAT}	Selected Charging Current	Default Value in the Register	CHRG_STAT[1:0]
< 2.2V	I _{SHORT}	80mA	01
2.2V to 3V	I _{PRECHG}	180mA	01
> 3V	I _{CHG}	2.048A	10

Note that in the DPM or thermal regulation modes, normal charging functions are temporarily modified: The charge current will be less than the value in the register; termination is disabled, and the charging safety timer is slowed down by counting at half clock rate.

DETAILED DESCRIPTION (continued)

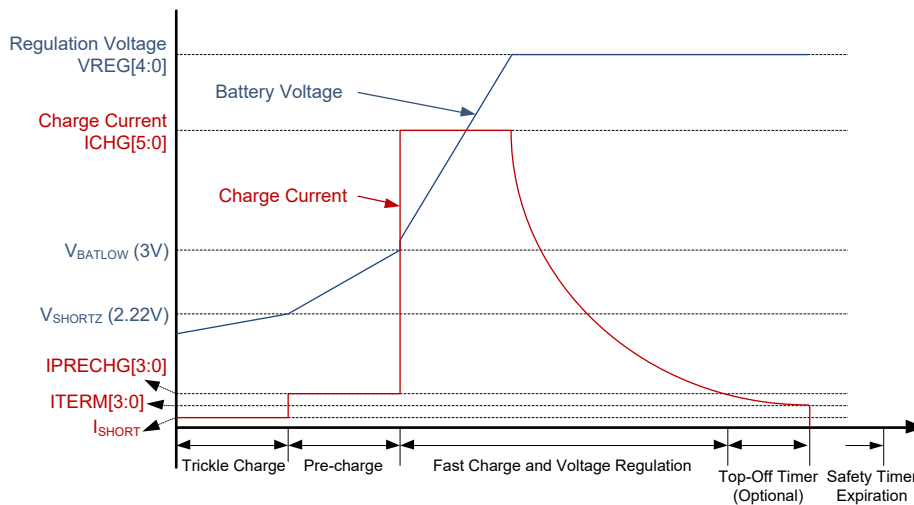

Figure 4. Battery Charging Profile

Termination

A charge cycle is terminated when the battery voltage is above the recharge threshold and the current falls below the programmed termination current. Unless there is a high power demand for system and need to operate in supplement mode, the BATFET turns off at the end of the charge cycle. Even after termination, the buck converter continues to operate to supply power to the system.

CHRG_STAT[1:0] is set to 11 and a negative pulse is sent to nINT pint after termination.

If the charger is regulating input current or voltage or junction temperature instead of charge current, termination will temporarily prevented. EN_TERM bit is termination control bit and can be set to 0 to disable termination before it happens.

At low termination currents (60mA TYP), the offset in the internal comparator may give rise to a higher (+10mA to +20mA) actual termination current. A delay in termination can be added (optional) as a compensation for comparator offset using a programmable top-off timer. During the delay, constant voltage charge phase continues and gives the falling charge current the chance to drop closer to the programmed value. The top-off delay timer has the same restrictions of the safety timer. As an example, if under some conditions the safety timer is suspended, the top-off timer will also suspend or if the safety timer is slowed down, the termination timer will

also slow down. The TOPOFF_ACTIVE bit reports the active/not active status of the top-off timer. The CHRG_STAT[1:0] and TOPOFF_ACTIVE bits can be read to find status of the termination.

Any of the following events resets the Top-off timer:

1. Disable to enable transition of nCE (charge enable).
2. A low to high change in the status of termination.
3. Set REG_RST bit to 1.

The setting of the top-off timer are applied at the time of termination detection and unless a new charge cycle is started, modifying the top-off timer parameters after termination has no effect. A negative pulse is sent to nINT when top-off timer is started or ended.

Temperature Qualification

The charging current and voltage of the battery must be limited when battery is cold or hot. A thermistor input for battery temperature monitoring is included in the device that can protect the battery based on JEITA guidelines. There is no battery temperature protection when battery is discharging to the system (either boosting or not charging).

DETAILED DESCRIPTION (continued)

Compliance with JEITA Guideline

JEITA guideline (April 20, 2007 release) is implemented in the device for safe charging of the Li-Ion battery. JEITA highlights the considerations and limits that should to be considered for charging at cold or hot battery temperatures. High charge current and voltage must be avoided outside normal operating temperatures (typically 0 °C and 60 °C). This functionality can be disabled if not needed. Four temperatures levels are defined by JEITA from T1 (minimum) to T4 (maximum). Outside this range charging should be stopped. The corresponding voltages sensed by NTC are named V_{T1} to V_{T4}. Due to the sensor negative resistance, a higher temperature results in a lower voltage on TS pin. The battery cool range is between T1 - T2 and the warm range is between T3 - T4. Charge must be limited in the cool and warm ranges.

One of the conditions for starting a charge cycle is having the TS voltage within V_{T1} to V_{T4} window limits. If during the charge, battery gets too cold or too hot and TS voltage exceeds the T1 - T4 limits, charging is suspended (zero charge current) and the controller waits for the battery temperature to come back within the T1 to T4 window.

JEITA recommends to reduce charge current to 1/2 of fast charging current or lower at cool temperatures (T1 - T2). For warmer temperature (within T3 - T4 range), charge voltage is recommended to be kept below 4.1V.

The SGM41511 exceeds the JEITA requirement by its flexible charge parameter settings. At warm temperature range (T3 - T4) the charge voltage can be set to VREG or 4.1V using the JEITA_VSET bit. At cool temperatures (T1 - T2), the current setting can be reduced down to 50% or 20% of fast charging current selectable by the JEITA_ISET bit.

A 103AT-2 type thermistor is recommended for use with the SGM41511. Other thermistors may be used and bias network (Figure 5) can be calculated based on the following equations:

$$R_{T2} = \frac{V_{REGN} \times R_{THCOLD} \times R_{THHOT} \times \left(\frac{1}{V_{T1}} - \frac{1}{V_{T4}} \right)}{R_{THHOT} \times \left(\frac{V_{REGN}}{V_{T4}} - 1 \right) - R_{THCOLD} \times \left(\frac{V_{REGN}}{V_{T1}} - 1 \right)} \quad (1)$$

$$R_{T1} = \frac{\left(\left(\frac{V_{REGN}}{V_{T1}} - 1 \right) \right)}{\left(\frac{1}{R_{T2}} \right) + \left(\frac{1}{R_{THCOLD}} \right)} \quad (2)$$

Where V_{T1}, V_{T4} and V_{REGN} are characteristics of the device and R_{THCOLD} and R_{THHOT} are thermistor resistances (R_{TH}) at desired T1 (Cold) and T4 (Hot) temperatures. Select T_{COLD} = 0°C and T_{HOT} = 60°C for Li-Ion or Li-polymer batteries. For a 103AT-2 type thermistor R_{THCOLD} = 27.28kΩ and R_{THHOT} = 3.02kΩ that results in:

- R_{T1} = 5.23kΩ
- R_{T2} = 30.1kΩ

Boost Mode Temperature Monitoring (Battery Discharge)

The device is capable to monitor the battery temperature for safety during the boost mode. The temperature must remain within the V_{BCOLD} to V_{BHOT} thresholds otherwise the boost mode will suspend and VBUS_STAT[2:0] bits are set to 000. Moreover NTC_FAULT[2:0] register is updated to report boost mode cold or hot condition. Once the temperature returns within the window, the boost mode is resumed and NTC_FAULT[2:0] register is cleared to 000 (normal).

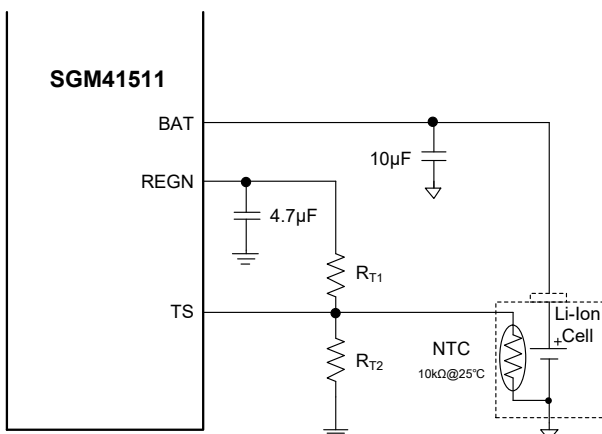

Figure 5. Battery Thermistor Connection and Bias Network

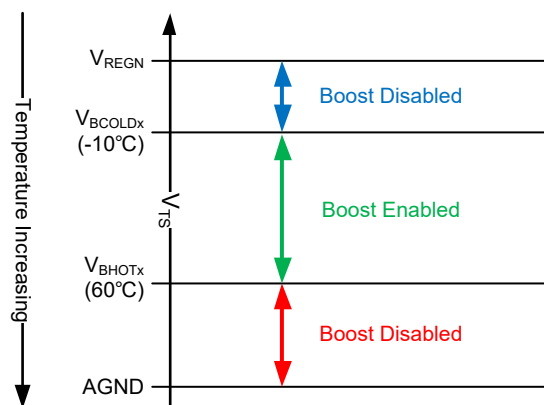

Figure 6. TS Pin Thermistor Temperature Window Settings in Boost Mode

DETAILED DESCRIPTION (continued)

Safety Timer

Abnormal battery conditions may result in prolonged charge cycles. An internal safety timer is considered to stop charging in such conditions. If the safety time is expired, CHRG_FAULT[1:0] bits are set to 11 and a negative pulse is sent to nINT pin. By default the charge time limit is 2 hours if the battery voltage does not rise above V_{BATLOW} threshold and 6 hours if it goes above V_{BATLOW}. This feature is optional and can be disabled by clearing EN_TIMER bit. The 6 hours limit can also be reduced to 4 hours by clearing CHG_TIMER bit.

The safety timer counts at half clock rate when charger is running under input voltage regulation, input current regulation, JEITA cool or thermal regulation because in these conditions, the actual charge current is likely to be less than the register setting. As an example, if the safety timer is set to 4 hours and the charger is regulating the input current (IINDPM_STAT bit = 1) in the whole charging cycle, the actual safety time will be 8 hours. Clearing the TMR2X_EN bit will disable the half clock rate feature.

The safety timer is paused if a fault occurs and charging is suspended. It will resume once the fault condition is removed. If charging cycle is stopped by a restart or by toggling nCE pin or CHG_CONFIG bit, the timer resets and restarts a new timing.

Narrow Voltage DC (NVDC) Design in SGM41511

The SGM41511 features an NVDC design using the BATFET that connects the system and battery. By using the linear region of the BATFET the charger regulates the system bus voltage (SYS pin) above the minimum setting using buck converter even if the battery voltage is very low. MOSFET linear mode allows for the large voltage difference between SYS and BAT pins to appear as V_{DS} across the switch while conducting and charging battery. SYS_MIN[2:0] register sets the minimum system voltage (default 3.5V). If the system is in minimum system voltage regulation, VSYS_STAT bit is set.

The BATFET operates in linear region when the battery voltage is below the minimum system voltage setting. The system voltage is regulated to 180mV (TYP) above the minimum system voltage setting. The battery gradually gets charged and its voltage rises above the minimum system voltage and lets BATFET to change from linear mode to fully turned-on switch such that the voltage difference between the system and battery is the small V_{DS} of fully on BATFET.

The system voltage is always regulated to 50mV (TYP) above the battery voltage if:

- 1) The charging is terminated or
- 2) Charging is disabled and the battery voltage is above the minimum system voltage setting.

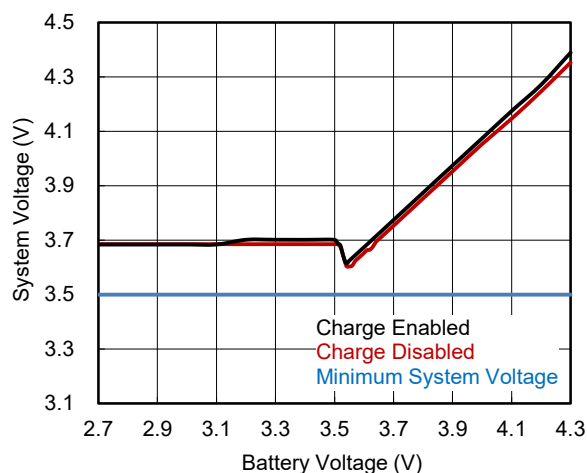

Figure 7. System Voltage vs. Battery Voltage

SGM41511 Dynamic Power Management (DPM)

The SGM41511 features a dynamic power management (DPM). To implement DPM the device always monitors the input current and voltage to regulate power demand from the source and avoid input adapter overloading or to meet the maximum current limits specified in the USB specs. Overloading an input source may result in either current trying to exceed the input current limit (I_{INDPM}) or the voltage tending to fall below the input voltage limit (V_{INDPM}). With DPM, the device keeps the V_{SYS} regulated to its minimum setting by reducing the battery charge current adequately such that the input parameter (voltage or current) does not exceed the limit. In other words, charge current is reduced to satisfy I_{IN} ≤ I_{INDPM} or V_{IN} ≥ V_{INDPM} whichever occurs first. DPM can be either an I_{IN} type (IINDPM) or V_{IN} type (VINDPM) depending on which limit is reached.

Changing to the supplement mode may be required if the charge current is decreased and reached to zero, but the input is still overloaded. In this case the charger reduces the system voltage below the battery voltage to allow operation in the supplement mode and provide a portion of system power demand from the battery through the BATFET.

The IINDPM_STAT or VINDPM_STAT status bits are set during an IINDPM or VINDPM respectively. Figure 8 summarizes the DPM behavior (IINDPM type) for a design example with a 9V/1.2A adapter, 3.2V battery, 2.8A charge current setting and 3.4V minimum system voltage setting.

DETAILED DESCRIPTION (continued)

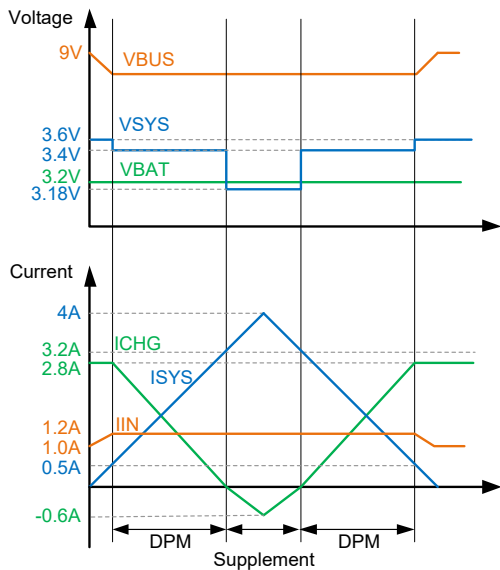

Figure 8. Input, Battery and System Voltage and Currents in DPM

Supplement Mode

If the system voltage drops below the battery voltage, the BATFET gradually starts to turn on. The threshold margin is 180mV if V_{SYS_MIN} setting is less than V_{BAT} and 45mV if V_{SYS_MIN} setting is larger than V_{BAT} . At low discharge currents, the BATFET gate voltage is regulated (R_{DS} modulation) such that the BATFET V_{DS} stays at 30mV. At higher currents, the BATFET will turn fully on (reaching its lowest $R_{DS(ON)}$). From this point, increasing the discharge current will linearly increase the BATFET V_{DS} (determined by $R_{DS(ON)} \times I_D$). Use of the MOSFET linear mode at lower currents prevents swinging oscillation of entering and exiting the supplement mode.

BATFET gate regulation V-I characteristics is shown in Figure 9. If the battery voltage falls below its minimum depletion, the BATFET turns off and exits supplement mode.

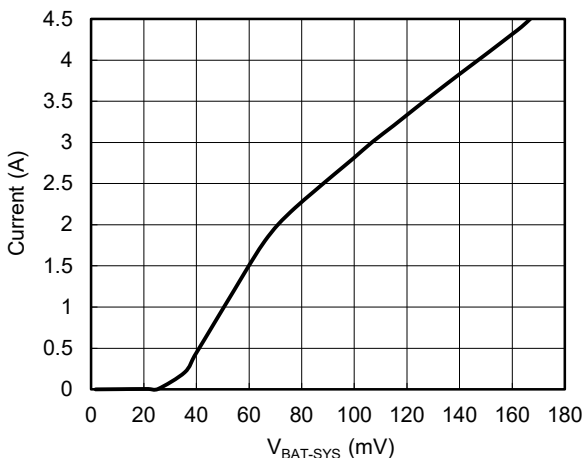

Figure 9. BATFET Gate Regulation V-I Curve

BATFET Control for System Power Reset and Ship Mode

Ship Mode (BATFET Disable)

Ship mode is usually used when the system is stored or in idle state for a long time or is in shipping. In such conditions, it is better to completely disconnect battery and make system voltage zero to minimize the leakage and extend the battery life. To enter ship mode, the BATFET has to be forced off by setting BATFET_DIS bit. The BATFET turns off immediately if BATFET_DLY bit is 0, or turns off after a t_{SM_DLY} delay (8 seconds) if BATFET_DLY is set.

Exit Ship Mode (BATFET Enable)

To exit the ship mode and enable the BATFET one of the following can be applied:

With no input power (no operating VBUS):

1. Connect the adapter to the input with a valid voltage to the VBUS input.
2. Pull nQON pin from logic high to low to enable BATFET for example by shorting nQON to GND. The negative pulse width should be at least a $t_{SHIPMODE}$ (1s TYP) for deglitching.

With the chip already powered by VBUS:

3. Clear BATFET_DIS bit using host and I²C.
4. Set REG_RST bit to reset all registers including BATFET_DIS bit to default (0).
5. Apply a negative pulse to nQON (same as 2).

Full System Reset with BATFET Using nQON

When the input source is not present, the BATFET can act as a load on/off switch between the system and battery. This feature can be used to apply a power-on reset to the system. Host can toggle BATFET_DIS bit to cycle power off/on and reset the system. A push-button connected to nQON pin or a negative pulse can also be used to manually force a system power cycle when BATFET is ON (BATFET_DIS bit = 0). For this function, a negative logic pulse with a minimum width of t_{QON_RST} (16s TYP) must be applied to the nQON pin that results in a temporary BATFET turn off for t_{BATFET_RST} (250ms TYP) that automatically turns on afterward. This functionality can be disabled by setting BATFET_RST_EN bit to 0.

DETAILED DESCRIPTION (continued)

In summary the nQON pin controls BATFET and system reset in two different ways:

1. Enable BATFET: Applying an nQON logic high to low transition with longer than $t_{SHIPMODE}$ deglitch time (negative pulse) turns on BATFET to exit ship mode (Figure 10 left).
2. Reset BATFET: By applying a logic low for a duration of at least t_{QON_RST} to nQON pin while VBUS is not powered and

BATFET is allowed to turn on (BATFET_DIS bit = 0), the BATFET turns off for t_{BATFET_RST} and then it is re-enabled resulting in a system power-on-reset. This function can be disabled by clearing BATFET_RST_EN bit (Figure 10 right).

A typical push bottom circuit for nQON is given in Figure 11.

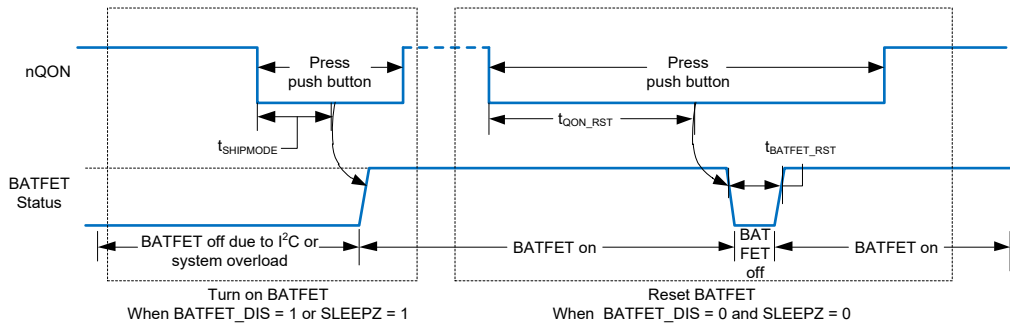

Figure 10. Left: nQON Timing to Exit Ship Mode (Enable BATFET), Right: System Power Reset (BATFET Temporarily Off)

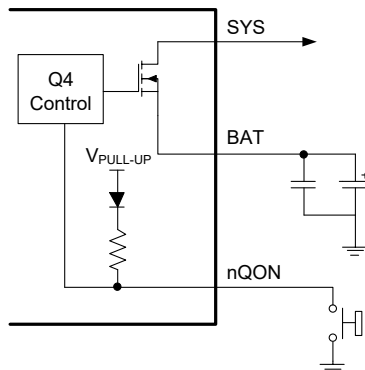

Figure 11. nQON Push Button Circuit

Status Outputs Pins (nPG, STAT and nINT)

Power Good Indication (nPG Pin and PG_STAT Bit)

When a good input source is connected to VBUS and input type is detected, the PG_STAT status bit goes high and the nPG pin goes low. A good input source is detected if all following conditions on V_{VBUS} are satisfied and input type detection is completed:

- V_{VBUS} is in the operating range: $V_{VBUS_UVLOZ} < V_{VBUS} < V_{VAC_OV}$.
- Device is not in sleep mode: $V_{VBUS} > V_{BAT} + V_{SLEEP}$.
- Input source is not poor: $V_{VBUS} > V_{VBUSMIN}$ (3.5V TYP) when I_{BAD_SRC} (30mA TYP) loading is applied. (Poor source detection.)
- Completed input source type detection.

Charge Status (STAT Pin)

Charging state is indicated with the open-drain STAT pin as explained in Table 4. This pin is able to drive an LED (see Figure 1). The functionality of the STAT pin is disabled if the EN_ICHG_MON[1:0] bits are set to 11.

Table 4. STAT Pin Function

Charging State	STAT Indicator
Charging battery (or recharge)	Low (LED ON)
Charge complete	High (LED OFF)
Charging is disabled or in sleep mode	High (LED OFF)
Charge is suspended due to input over-voltage, TS fault, timer faults or system over-voltage or boost mode is suspended (TS fault).	1Hz Blinking

DETAILED DESCRIPTION (continued)

nINT Interrupt Output Pin

When a new update occurs in the charger states a 256 μ s negative pulse is sent through the nINT pin to interrupt the host. The host may not continuously monitor the charger device and by receiving the interrupt it can react and check the charger situation on time.

The following events can generate an interrupt pulse:

1. All faults reflected in REG09 register (watchdog, boost overload, charge faults, battery over-voltage and NTC).
2. Charging completed.
3. PSEL identified a connected source (USB or adapter).
4. Input source voltage entered the "input good" range:
 - a) V_{VBUS} exceeded V_{BAT} (not in sleep mode).
 - b) V_{VBUS} came below V_{VAC_OV} .
 - c) V_{VBUS} remained above $V_{VBUSMIN}$ (3.5V TYP) when I_{BAD_SRC} (30mA TYP) load current is applied.
5. Input removed or out of the "input good" range.
6. A DPM event (VINDPM or IINDPM) occurred (a maskable interrupt).

Once a fault happens, the INT pulse is asserted once and the fault bits are updated in REG09. Fault status is not reset in the register until the host reads it. A new fault will not assert a new INT pulse until the host reads REG09 and all the previous faults are cleared. Therefore in order to read the current time faults the host must read REG09 two times consecutively. The first read returns the history of the fault register status (from the time of the last read or reset) and the second one checks the current active faults. The only exception is NTC_FAULT which always reports the actual real time condition of the TS pin.

REG09 does not support multi-read and multi-write as will be explained later.

SGM41511 Protection Features

Monitoring of Voltage and Current

During the converter operation the input and system voltages (VBUS and VSYS) and switch currents are constantly monitored to assure safe operation of the device in both buck and boost modes as will be explained below.

Buck Mode Voltage and Current Monitoring

1. Input Over-Voltage (ACOV)

Converter switching will stop as soon as VBUS voltage exceeds V_{VAC_OV} over-voltage limit that is programmable by OVP[1:0] in REG06. It is selectable between 5.5V, 6.5V (default), 10.5V and 14V for USB or 5V, 9V or 12V adaptors respectively.

Each time VBUS exceeds the OVP limit, an INT pulse is asserted and as long as the overvoltage persists, the CHRG_FAULT[1:0] bits are set to 01 in REG09. Fault will

clear to 00 if the voltage comes back below limit (and a hysteresis threshold) and host reads the fault register. Charger resumes its normal operation when the voltage comes back below OVP limit.

2. System Over-Voltage (SYSOVP)

During a system load transient, the device clamps the system voltage to protect the system components from over-voltage. The SYSOVP over-voltage limit threshold is $350\text{mV} + V_{SYSMIN}$ (programmed minimum system regulation voltage + 350mV). Once a SYSOVP occurs, switching stops to clamp any overshoot and a 30mA sink current is applied to SYS to pull the voltage down.

Boost Mode Voltage and Current Monitoring

In boost mode the RBFET (reverse blocking) and LSFET (low-side switch) FET currents and VBUS voltage are monitored for protection.

1. Soft-Start on VBUS

Boost mode begins with a soft-start to prevent large inrush currents the when it is enabled.

2. Output Short Protection for VBUS

Short circuit protection is provided for VBUS output in boost mode. To accept different types of load connected to VBUS and OTG adaptation, an accurate constant current regulation control is implemented for boost mode. In case of a short circuit on VBUS pin, the boost turns off and retries 7 times (Hiccup). If short is not removed after retries, the OTG will disable by clearing OTG_CONFIG bit. Also, an INT pulse is sent and the BOOST_FAULT bit is set to 1 in REG09. Enabling the boost mode again by host, clears the BOOST_FAULT bit.

3. Output Over-Voltage Protection for VBUS

In boost mode converter stops switching and exits boost mode (by clearing OTG_CONFIG bit) if VBUS voltage rises above regulation and exceeds the V_{OTG_OVP} over-voltage limit (6.015V TYP). An INT pulse is sent and the BOOST_FAULT bit is set 1.

SGM41511 Thermal Regulation and Shutdown

Buck Mode Thermal Protections

Internal junction temperature (T_J) is always monitored to avoid overheating. A limit of 120°C is considered for maximum IC surface temperature in buck mode and if T_J intends to exceed this level, the device reduces the charge current to keep maximum temperature limited to 120°C (thermal regulation mode) and sets the THERM_STAT bit to 1. As expected the actual charging current is usually lower than programmed value during thermal regulation therefore, the safety timer runs at half clock rate and charge termination is disabled during thermal regulation.

DETAILED DESCRIPTION (continued)

If the temperature exceeds T_{SHUT} (150°C), thermal shutdown protection arise in which the converter and BATFET are turned off, CHRG_FAULT[1:0] bits are set to 10 in the fault register and an INT pulse is sent.

When the device recovers and T_J falls below the hysteresis band of T_{SHUT_HYS} (20°C under T_{SHUT}), the converter and BATFET resume automatically.

Boost Mode Thermal Protections

Similar to buck mode, T_J is monitored in boost mode for thermal shutdown protection. If junction temperature exceeds T_{SHUT} (150°C), BATFET will turn off and the boost mode will be disabled (OTG_CONFIG bit clears). BATFET will resume if T_J falls below the hysteresis band of T_{SHUT_HYS} (20°C under T_{SHUT}). Boost can recover again by re-enabling OTG_CONFIG bit by host.

Battery Protections

Battery Over-Voltage Protection (BATOVP)

The over-voltage limit for the battery is 4% above the battery regulation voltage setting. In case of a BATOVP, charging stops right away, the BAT_FAULT bit is set to 1 and an INT pulse is sent.

Battery Over-Discharge Protection

If battery discharges too much and V_{BAT} falls below the depletion level ($V_{BAT_DPL_FALL}$), the device turns off BATFET to protect battery. This protection is latched and is not recovered until an input source is connected to the VBUS pin. In such condition, the battery will start charging with the small I_{SHORT} current (80mA TYP) first as long as $V_{BAT} < V_{SHORTZ}$. When battery voltage is increased and $V_{SHORTZ} < V_{BAT} < V_{BATLOW}$, the charge current will increase to the pre-charge current level programmed in the IPRECHG[3:0] register.

Battery Over-Current Protection for System

The BATFET will latch off, if its current limit is exceeded due to a short or large overload on the system ($I_{BAT} > I_{BATOP}$). To reset this latch off and enable BATFET, the "Exit Ship Mode" procedure must be followed.

I²C Serial Interface and Data Communication

Standard I²C interface is used to program SGM41511 parameters and get status reports. I²C is well known 2 wire serial communication interface that can connect one (or more) master device(s) to some slave devices for two-way communication. The bus lines are named serial data (SDA) and serial clock (SCL). The device that initiates a data transfer is a master and generates the SCL clock as long as it is master. Slave devices have unique addresses to identify. A master is typically a micro controller or a digital signal processor.

The SGM41511 operates as a slave device with address 0x6B (6BH). It has twelve 8-bit registers, numbered from REG00 to REG0B. A register read beyond REG0B (0x0B) returns 0xFF.

Physical Layer

The SGM41511 supports I²C standard mode (up to 100kbit/s) and fast mode (up to 400kbit/s) communication speeds. Bus lines are pulled high by weak current source or pull-up resistors are in logic high state with no clocking when the bus is free. The SDA and SCL pins are open-drain.

I²C Data Communication

START and STOP Conditions

A transaction is started by taking control of the bus by master if the bus is free. The transaction is terminated by releasing the bus when the data transfer job is done as shown in Figure 12. All transactions begin by the master who applies a START condition on the bus lines to take over the bus and exchange data. At the end, the master terminates the transaction by applying one (or more) STOP condition. START condition is when SCL is high and a high to low transition on the SDA is generated by master. Similarly, a STOP is defined when SCL is high and SDA goes from low to high. START and STOP are always generated by a master. After a START and before a STOP the bus is considered busy.

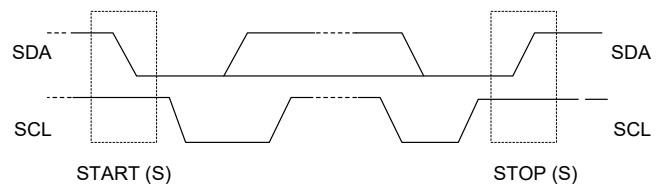

Figure 12. I²C Bus in START and STOP Conditions

Data Bit Transmission and Validity

The data bit (high or low) must remain stable on the SDA line during the HIGH period of the clock. The state of the SDA can only change when the clock (SCL) is LOW. For each data bit transmission, one clock pulse is generated by master. Bit transfer in I²C is shown in Figure 13.

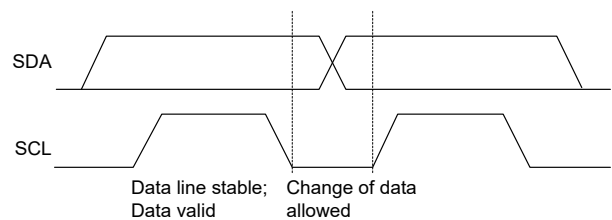

Figure 13. I²C Bus Bit Transfer

DETAILED DESCRIPTION (continued)

Byte Format

Data is transmitted in 8-bit packets (one byte at a time). The number of bytes in one transaction is not limited. In each packet the 8 bits are sent successively with the Most Significant Bit (MSB) first. An acknowledge (or not-acknowledge) bit must come after the 8 data bits. This bit informs the transmitter whether the receiver is ready to proceed for the next byte or not. If the slave is busy and cannot transfer another byte of data, it can hold the SCL line low and keep the master in a wait state (called clock stretching). When the slave is ready for another byte of data, it releases the clock line and data transfer can continue with clocks generated by master. Figure 14 shows the byte transfer process with I²C interface.

Acknowledge (ACK) and Not Acknowledge (NCK)

After transmission of each byte by transmitter an acknowledge bit is replied by the receiver as ninth bit. With the acknowledge bit the receiver informs the transmitter that the byte was received, and another byte is expected or can be sent (ACK) or it is not expected (NCK = not ACK). Clock (SCL) is always generated by the master, including for the acknowledge ninth bit, no matter who is acting as transmitter or receiver. SDA line is released for receiver control during the acknowledge clock pulse and the receiver can pull the SDA line low as ACK (reply a 0 bit) or let it be high as NCK during the SCL high pulse. After that the master can either STOP (P) to end the transaction or send a new START (S) condition to start a new transfer (called repeated start). For example, when master wants to read a register in slave, one start is needed to send the slave address and register address and then without a stop condition another start is sent by master to initiate the receiving transaction from slave. Master then sends the STOP condition and releases the bus.

Data Direction Bit and Addressing Slaves

The first byte sent by master after the START is always the target slave address (7 bits) and an eighth data-direction bit (R/W). R/W bit is 0 for a WRITE transaction and 1 for READ (when master is asking for data). Data direction is the same for all next bytes of the transaction. To reverse it, a new START or repeated START condition must be sent by master (STOP will end the transaction). Usually the second byte is also a WRITE sending the register address that is supposed to be accesses in the next byte(s).

WRITE: If the master wants to write in the register, the third byte can be written directly as shown in Figure 16 for a single write data transfer. After receiving the ACK, master may issue a STOP condition to end the transaction or send the next register data, that will be written to the next address in a slave as multi-write. A STOP is needed after sending the last data.

READ: If the master wants to read a single register (Figure 17), it sends a new START condition along with device address with R/W bit = 1. After ACK is received, master reads the SDA line to receive the content of the register. Master replies with NCK to inform slave that no more data is needed (single read) or it can send an ACK to request for sending the next register content (multi-read). This can continue until a NAK is sent by master. A STOP must be sent by master in any case to end the transaction.

In the figures the data blocks with gray background show the bits sent by master and the white background represent data bits sent by slave. If the register address is not defined, the device replies with NCK and goes back to the I²C slave idle state.

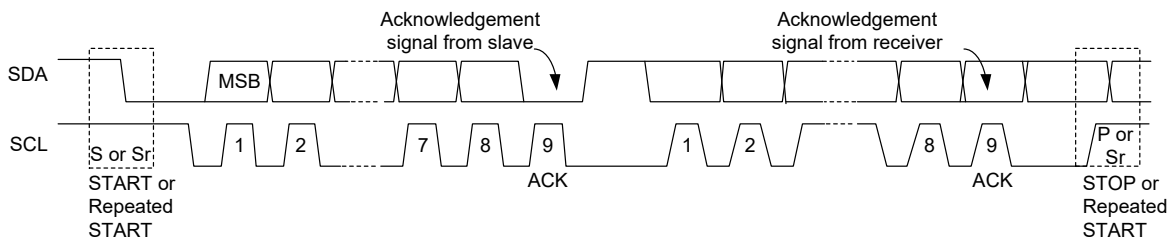

Figure 14. Data Transfer on the I²C Bus

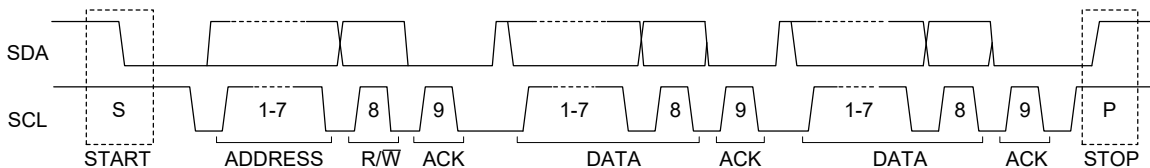

Figure 15. A Complete Data Transfer Transaction

DETAILED DESCRIPTION (continued)

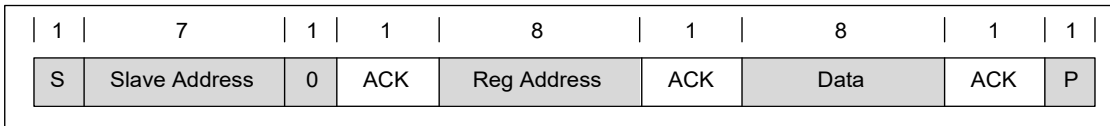

Figure 16. A Single Write Transaction

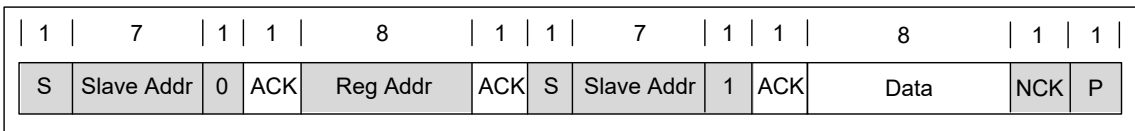

Figure 17. A Single Read Transaction

Data Transactions with Multi-Read or Multi-Write
 Multi-read and multi-write are supported by SGM41511 for REG00 through REG0B registers, except for REG09 as explained in Figure 18 and Figure 19. REG09 (fault register), is skipped in multi-read/writes. In the multi-write, every new data byte sent by master is written to the next register of the device. A STOP is sent whenever master is done with writing into device registers.

In a multi-read transaction, after receiving the first register data (whose address is already written to the slave), the master replies with an ACK to ask the slave for sending the next register data. This can continue as much as it is needed by master. Master sends back an NCK after the last received byte and issues a STOP condition.

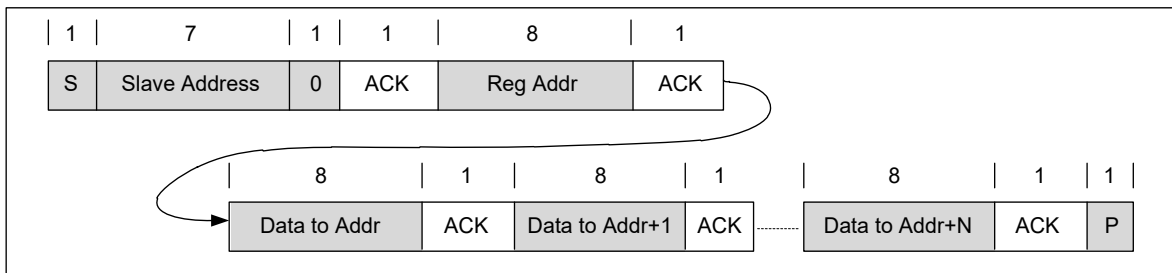

Figure 18. A Multi-Write Transaction

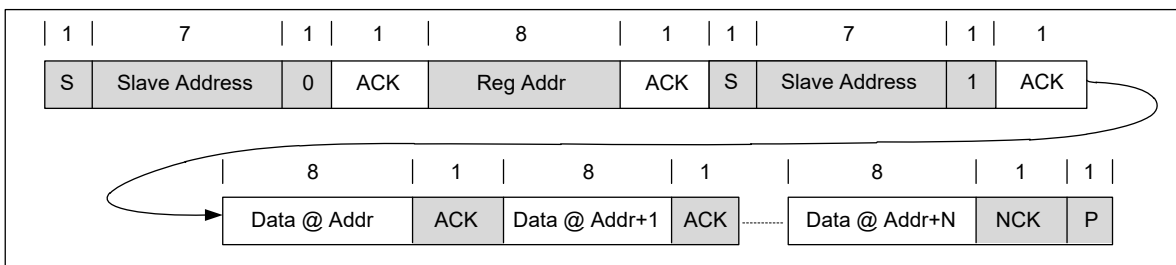

Figure 19. A Multi-Read Transaction

REGISTER MAPS

All registers are 8-bit and individual bits are named from D[0] (LSB) to D[7] (MSB).

I²C Slave Address of SGM41511 is: 0x6B

R/W: Read/Write bit(s)

R: Read only bit(s)

PORV: Power-On-Reset Value

n: Parameter code formed by the bits as an unsigned binary number.

REG00

Register address: 0x00; R/W

PORV = 00010111

Table 5. REG00 Register Details

BITS	BIT NAME	DESCRIPTION	COMMENT	PORV	TYPE	RESET BY
D[7]	EN_HIZ	Enable HIZ Mode 0 = Disable (default) 1 = Enable	In HIZ mode, the VBUS pin is effectively disconnected from internal circuit. Some leakage current may exist.	0	R/W	REG_RST or Watchdog
D[6:5]	EN_ICHG_MON[1:0]	Enable STAT Pin Function 00 = Enable (default) 01 = Reserved 10 = Reserved 11 = Disable (float pin)	These bits turn on or off the function of the STAT open-drain output pin (charge status indicator).	00	R/W	REG_RST
D[4:0]	IINDPM[4:0]	IINDPM[4] 1 = 1600mA	Input Current Limit Value (n: 5 bits): = 100 + 100n (mA) Offset: 100mA Range: 100mA (00000) - 3.2A (11111) Default: 2400mA (10111), not typical IINDPM changes based on PSEL state after an input source detection as follows: PSEL = High → IINDPM = 500mA PSEL = Low → IINDPM = 2400mA Host can overwrite IINDPM after input source detection is completed.	10111	R/W	REG_RST
		IINDPM[3] 1 = 800mA				
		IINDPM[2] 1 = 400mA				
		IINDPM[1] 1 = 200mA				
		IINDPM[0] 1 = 100mA				

**I²C Controlled 3A Single-Cell Battery Charger with High Input Voltage
SGM41511 Capability and Narrow Voltage DC (NVDC) Power Path Management**

REGISTER MAPS (continued)

REG01

Register address: 0x01; R/W

PORV = 00011010

Table 6. REG01 Register Details

BITS	BIT NAME	DESCRIPTION	COMMENT	PORV	TYPE	RESET BY
D[7]	PFM_DIS	Enable PFM Mode 0 = Enable (default) 1 = Disable	Enable Pulse Frequency Modulation. PFM is normally used to save power at light load by reducing converter switching frequency.	0	R/W	REG_RST
D[6]	WD_RST	I ² C Watchdog Timer Reset 0 = Normal (default) 1 = Reset	Watchdog Timer Reset Control Bit. Write 1 to this bit to avoid watchdog expiry. WD_RST resets to 0 after watchdog timer reset (expiry).	0	R/W	REG_RST or Watchdog
D[5]	OTG_CONFIG	Enable OTG 0 = OTG disable (default) 1 = OTG enable	This bit has priority over charge enable in the CHG_CONFIG.	0	R/W	REG_RST or Watchdog
D[4]	CHG_CONFIG	Enable Battery Charging 0 = Charge disable 1 = Charge enable (default)	Charge is enabled when CHG_CONFIG bit is 1 and nCE pin is pulled low.	1	R/W	REG_RST or Watchdog
D[3:1]	SYS_MIN[2:0]	Minimum System Voltage 000 = 2.6V 001 = 2.8V 010 = 3V 011 = 3.2V 100 = 3.4V 101 = 3.5V (default) 110 = 3.6V 111 = 3.7V	Minimum System Voltage Value. Offset: 2.6V Range: 2.6V (000) - 3.7V (111) Default: 3.5V (101)	101	R/W	REG_RST
D[0]	MIN_BAT_SEL	Minimum Battery Voltage for OTG Mode 0 = 2.8V V _{BAT} falling (default) 1 = 2.5V V _{BAT} falling	Default: V _{BAT} falling, V _{BATLOW_OTG} = 2.8V. V _{BAT} rising, V _{BATLOW_OTG} = 3.0V.	0	R/W	REG_RST

REG02

Register address: 0x02; R/W

PORV = 10100010

Table 7. REG02 Register Details

BITS	BIT NAME	DESCRIPTION	COMMENT	PORV	TYPE	RESET BY
D[7]	BOOST_LIM	Boost Mode Current Limit 0 = 0.5A 1 = 1.2A (default)	The current limit options listed values are the minimum specs. Actual value is typically higher.	1	R/W	REG_RST or Watchdog
D[6]	Q1_FULLON	VBUS FET SWITCH (Q1) 0 = Use higher R _{DS(on)} if I _{INDPM} < 700mA (for better accuracy) 1 = Use lower R _{DS(on)} always (fully ON for better efficiency)	Used to control the on-resistance of Q1 (VBUS switch) for better input current measurement accuracy. In boost mode, full FET is always used, and this bit has no effect.	0	R/W	REG_RST
D[5:0]	ICHG[5:0]	ICHG[5] 1 = 1920mA	Fast Charge Current Value (n: 6 bits): = 60n (mA) (n ≤ 50) Offset: 0mA Range: 0mA (000000) - 3000mA (110010) Default: 2040mA (100010) Notes: Setting I _{CHG} = 0mA disables charge. Values above 50D = 110010 (3000mA) are clamped to 50D = 110010 (3000mA).	1	R/W	REG_RST or Watchdog
		ICHG[4] 1 = 960mA		0	R/W	
		ICHG[3] 1 = 480mA		0	R/W	
		ICHG[2] 1 = 240mA		0	R/W	
		ICHG[1] 1 = 120mA		1	R/W	
		ICHG[0] 1 = 60mA		0	R/W	

REGISTER MAPS (continued)

REG03 (Pre-Charge and Termination Current Settings)

Register address: 0x03; R/W

PORV = 00100010

Table 8. REG03 Register Details

BITS	BIT NAME	DESCRIPTION	COMMENT	PORV	TYPE	RESET BY
D[7:4]	IPRECHG[3:0]	IPRECHG[3] 1 = 480mA	Pre-Charge Current Limit (n: 4 bits): = 60 + 60n (mA) (n ≤ 12) Offset: 60mA Range: 60mA (0000) - 780mA (1100) Default: 180mA (0010) Note: Values above 12D = 1100 (780mA) are clamped to 12D = 1100 (780mA).	0	R/W	REG_RST or Watchdog
		IPRECHG[2] 1 = 240mA		0	R/W	
		IPRECHG[1] 1 = 120mA		1	R/W	
		IPRECHG[0] 1 = 60mA		0	R/W	
D[3:0]	ITERM[3:0]	ITERM[3] 1 = 480mA	Termination Current Limit (n: 4 bits): = 60 + 60n (mA) Offset: 60mA Range: 60mA (0000) - 960mA (1111) Default: 180mA (0010)	0	R/W	REG_RST or Watchdog
		ITERM[2] 1 = 240mA		0	R/W	
		ITERM[1] 1 = 120mA		1	R/W	
		ITERM[0] 1 = 60mA		0	R/W	

REG04

Register address: 0x04; R/W

PORV = 01011000

Table 9. REG04 Register Details

BITS	BIT NAME	DESCRIPTION	COMMENT	PORV	TYPE	RESET BY
D[7:3]	VREG[4:0]	VREG[4] 1 = 512mV	Charge Voltage Limit (n: 5 bits): = 3856 + 32n (mV) if n ≤ 24, n≠15; = 4.352V if n = 15 Offset: 3.856V Range: 3.856V (00000) - 4.624V (11000) Default: 4.208V (01011) Special Value: 4.352V (01111) Note: Values above 24D = 11000 (4.624V) are clamped to 24D = 11000 (4.624V).	0	R/W	REG_RST or Watchdog
		VREG[3] 1 = 256mV		1	R/W	
		VREG[2] 1 = 128mV		0	R/W	
		VREG[1] 1 = 64mV		1	R/W	
		VREG[0] 1 = 32mV		1	R/W	
D[2:1]	TOPOFF_TIMER[1:0]	Top-Off Timer 00 = Disabled (default) 01 = 15 minutes 10 = 30 minutes 11 = 45 minutes	The charge extension time added after the termination condition is detected. If disabled, charging terminates as soon as termination conditions are met.	0	R/W	REG_RST or Watchdog
				0	R/W	
D[0]	VRECHG	Battery Recharge Threshold 0 = 100mV below VREG[4:0] (default) 1 = 200mV below VREG[4:0]	A recharge cycle will start if a fully charged battery voltage drops below VREG - VRECHG settings.	0	R/W	REG_RST or Watchdog

REGISTER MAPS (continued)

REG05

Register address: 0x05; R/W

PORV = 10011111

Table 10. REG05 Register Details

BITS	BIT NAME	DESCRIPTION	COMMENT	PORV	TYPE	RESET BY
D[7]	EN_TERM	Charging Termination Enable 0 = Disable 1 = Enable (default)		1	R/W	REG_RST or Watchdog
D[6]	Reserved	Reserved	Reserved.	0	R/W	REG_RST or Watchdog
D[5:4]	WATCHDOG[1:0]	Watchdog Timer Setting 00 = Disable watchdog timer 01 = 40s (default) 10 = 80s 11 = 160s	Expiry time of the watchdog timer if it is not reset.	01	R/W	REG_RST or Watchdog
D[3]	EN_TIMER	Charge Safety Timer Enable 0 = Disable 1 = Enable (default)	When enabled the pre-charge and fast charge periods are included in the timing.	1	R/W	REG_RST or Watchdog
D[2]	CHG_TIMER	Charge Safety Timer Setting 0 = 4hrs 1 = 6hrs (default)		1	R/W	REG_RST or Watchdog
D[1]	TREG	Thermal Regulation Threshold 0 = 80°C 1 = 120°C (default)	For buck mode.	1	R/W	REG_RST or Watchdog
D[0]	JEITA_ISET (0°C - 10°C)	JEITA Charging Current 0 = 50% of I _{CHG} 1 = 20% of I _{CHG} (default)		1	R/W	REG_RST or Watchdog

REG06

Register address: 0x06; R/W

PORV = 01100110

Table 11. REG06 Register Details

BITS	BIT NAME	DESCRIPTION	COMMENT	PORV	TYPE	RESET BY
D[7:6]	OVP[1:0]	VAC Pin OVP Threshold 00 = 5.5V 01 = 6.5V (5V input) (default) 10 = 10.5V (9V input) 11 = 14V (12V input)	OVP Threshold for Input Supply.	0	R/W	REG_RST
				1	R/W	
D[5:4]	BOOSTV[1:0]	Boost Mode Voltage Regulation 00 = 4.85V 01 = 5.00V 10 = 5.15V (default) 11 = 5.30V		1	R/W	REG_RST
				0	R/W	
D[3:0]	VINDPM[3:0]	VINDPM[3] 1 = 800mV	VINDPM Threshold (n: 4 bits): = 3.9V + 0.1n (V) Offset: 3.9V Range: 3.9V (0000) - 5.4V (1111) Default: 4.5V (0110)	0	R/W	REG_RST
		VINDPM[2] 1 = 400mV		1	R/W	
		VINDPM[1] 1 = 200mV		1	R/W	
		VINDPM[0] 1 = 100mV		0	R/W	

REGISTER MAPS (continued)

REG07

Register address: 0x07; R/W

PORV = 01001100

Table 12. REG07 Register Details

BITS	BIT NAME	DESCRIPTION	COMMENT	PORV	TYPE	RESET BY
D[7]	IINDET_EN	Input Current Limit Detection 0 = Not in input current limit detection (default) 1 = Force input current limit detection when VBUS is present	Reloads with 0 when input detection is completed.	0	R/W	REG_RST or Watchdog
D[6]	TMR2X_EN	Enable Half Clock Rate Safety Timer 0 = Disable 1 = Safety timer slow down during DPM, JEITA cool, or thermal regulation (default)	Slow down by a factor of 2.	1	R/W	REG_RST or Watchdog
D[5]	BATFET_DIS	Disable BATFET 0 = Allow BATFET (Q4) to turn on (default) 1 = Turn off BATFET (Q4) after a t_{SM_DLY} delay time (REG07 D[3])	t_{SM_DLY} is typically 8 seconds.	0	R/W	REG_RST
D[4]	JEITA_VSET (45°C - 60°C)	JEITA Charging Voltage 0 = Set charge voltage to 4.1V (MAX) (default) 1 = Set charge voltage to V_{REG}		0	R/W	REG_RST or Watchdog
D[3]	BATFET_DLY	BATFET Turn Off Delay Control 0 = Turn off BATFET immediately 1 = Turn off BATFET after t_{SM_DLY} (default)	BATFET_DIS bit is set.	1	R/W	REG_RST
D[2]	BATFET_RST_EN	Enable BATFET Reset 0 = Disable BATFET reset 1 = Enable BATFET reset (default)		1	R/W	REG_RST or Watchdog
D[1:0]	VDPM_BAT_TRACK[1:0]	Dynamic VINDPM Tracking 00 = Disable (V_{INDPM} set by register) 01 = $V_{BAT} + 200mV$ 10 = $V_{BAT} + 250mV$ 11 = $V_{BAT} + 300mV$	Set VINDPM[3:0] to track V_{BAT} voltage. Actual V_{INDPM} is the larger of this register value and $V_{BAT} + VDPM_BAT_TRACK[1:0]$ offset.	0 0	R/W R/W	REG_RST

REGISTER MAPS (continued)

REG08 (Status Bits, Read Only)

Register address: 0x08; R

PORV = xxxxxxxx

Table 13. REG08 Register Details

BITS	BIT NAME	DESCRIPTION	PORV	TYPE	RESET BY
D[7:5]	VBUS_STAT[2:0]	VBUS Status Register (SGM41511) 000 = No input 001 = USB host SDP (500mA) → PSEL HIGH 010 = Adapter 2.4A → PSEL LOW 111 = OTG Other values are reserved. Current limit value is reported in IINDPM[4:0] register.	x	R	NA
			x	R	
			x	R	
D[4:3]	CHRG_STAT[1:0]	Charging Status 00 = Charge disable 01 = Pre-charge ($V_{BAT} < V_{BATLOW}$) 10 = Fast charging (constant current or voltage) 11 = Charging terminated	x	R	NA
			x	R	
D[2]	PG_STAT	Input Power Status (VBUS in good voltage range and not poor) 0 = Input power source is not good 1 = Input power source is good	x	R	NA
D[1]	THERM_STAT	Thermal Regulation Status 0 = Not in thermal regulation 1 = In thermal regulation	x	R	NA
D[0]	VSYS_STAT	System Voltage Regulation Status 0 = Not in VSYSMIN regulation ($V_{BAT} > V_{SYS_MIN}$) 1 = In VSYSMIN regulation ($V_{BAT} < V_{SYS_MIN}$)	x	R	NA

REG09 (Fault Bits, Read Only)

Register address: 0x09; R

PORV = xxxxxxxx

Table 14. REG09 Register Details

BITS	BIT NAME	DESCRIPTION	PORV	TYPE	RESET BY
D[7]	WATCHDOG_FAULT	Watchdog Fault Status 0 = Normal (no fault) 1 = Watchdog timer expired	x	R	NA
D[6]	BOOST_FAULT	Boost Mode Fault Status 0 = Normal 1 = VBUS overloaded in OTG, or VBUS OVP, or battery voltage too low (any condition that prevents boost starting)	x	R	NA
D[5:4]	CHRG_FAULT[1:0]	Charging Fault Status 00 = Normal 01 = Input fault (VAC OVP or $V_{BAT} < V_{VBUS} < 3.8V$) 10 = Thermal shutdown 11 = Charge safety timer expired	x	R	NA
			x	R	
D[3]	BAT_FAULT	Battery Fault Status 0 = Normal 1 = Battery over-voltage (BATOVP)	x	R	NA
D[2:0]	NTC_FAULT[2:0]	JEITA Condition Based on Battery NTC Temperature Measurement 000 = Normal 010 = Warm 011 = Cool (buck mode only) 101 = Cold 110 = Hot NTC fault bits are updated in real time and does not need a read to reset.	x	R	NA
			x	R	
			x	R	

REGISTER MAPS (continued)

REG0A

Register address: 0x0A; R and R/W

PORV = xxxxxx00

Table 15. REG0A Register Details

BITS	BIT NAME	DESCRIPTION	PORV	TYPE	RESET BY
D[7]	VBUS_GD	Good Input Source Detected 0 = A good VBUS is not attached 1 = A good VBUS attached	x	R	NA
D[6]	VINDPM_STAT	Input Voltage Regulation (Dynamic Power Management) 0 = Not in VINDPM 1 = In VINDPM	x	R	NA
D[5]	IINDPM_STAT	Input Current Regulation (Dynamic Power Management) 0 = Not in IINDPM 1 = In IINDPM	x	R	NA
D[4]	Reserved		x	R	NA
D[3]	TOPOFF_ACTIVE	Active Top-Off Timer Counting Status 0 = Top-off timer not counting 1 = Top-off timer counting	x	R	NA
D[2]	ACOV_STAT	Input Over-Voltage Status (AC adaptor is the input source) 0 = No over-voltage (no ACOV) 1 = Over-voltage detected (ACOV)	x	R	NA
D[1]	VINDPM_INT_MASK	VINDPM Event Detection Interrupt Mask 0 = Allow VINDPM INT pulse 1 = Mask VINDPM INT pulse	0	R/W	REG_RST
D[0]	IINDPM_INT_MASK	IINDPM Event Detection Mask 0 = Allow IINDPM to send INT pulse 1 = Mask IINDPM INT pulse	0	R/W	REG_RST

REG0B

Register address: 0x0B; R and R/W

PORV = 000101xx

Table 16. REG0B Register Description

BITS	BIT NAME	DESCRIPTION	PORV	TYPE	RESET BY
D[7]	REG_RST	Register Reset 0 = No effect (Keep current register settings) 1 = Reset R/W bits of all registers to the default and reset safety timer (It also resets itself to 0 after register reset is completed.)	0	R/W	REG_RST
D[6:3]	PN[3:0]	Part ID 0010 = SGM41511	0	R	NA
			0	R	
			1	R	
			0	R	
D[2]	SGMPART		1	R	NA
D[1:0]	DEV_REV[1:0]	Revision	x	R	NA
			x	R	

APPLICATION INFORMATION

The SGM41511 is typically used as a charger with power path management in smart phones, tablets and other portable devices. In a design it comes along with a host controller (a processor with I²C interface) and a single-cell Li-Ion or Li-polymer battery.

Detailed Design Procedure

Inductor Design

Small energy storage elements (inductor and capacitor) can be used thanks to the high frequency (1.5MHz) switching converter used in the SGM41511. Inductor should tolerate currents higher than the maximum charge current (I_{CHG}) plus half the inductor peak to peak ripple current (ΔI) without saturation:

$$I_{SAT} > I_{CHG} + \frac{\Delta I}{2} \quad (3)$$

The inductor ripple current is determined by the input voltage (V_{VBUS}), duty cycle ($D = V_{BAT}/V_{VBUS}$), switching frequency ($f_s = 1.5\text{MHz}$) and the inductance (L). In CCM we have:

$$\Delta I = \frac{V_{VBUS} \times D \times (1-D)}{f_s \times L} \quad (4)$$

Inductor ripple current is maximum when $D \approx 0.5$. If the input voltage range (V_{VBUS}) is limited higher D values can be considered.

In a practical designs, inductor peak to peak current ripple is selected in a range between 20% to 40% of the maximum DC current $\Delta I = (0.2 \sim 0.4) \times I_{CHG}$ for a good trade-off between inductor size and efficiency. Selecting higher ripple allows choosing of smaller inductance for a small increase in loss.

For each application, V_{VBUS} and I_{CHG} are known, so L can be calculated from (4) and current rating of the inductor can be selected from (3). Choose an inductor that has small DCR and core losses at 1.5MHz to have high efficiency and cool operation at full load.

Input Capacitor Design

Select low ESR ceramic input capacitor (X7R or X5R) with sufficient voltage and RMS ripple current rating for decoupling of the input switching ripple current (I_{CIN}). The RMS ripple current in the worst case is around the $I_{CHG}/2$ when $D \approx 0.5$. If the converter does not operate at $D \approx 50\%$, the worst case capacitor RMS current can be estimated from (5) in which D is the closest operating duty cycle to 0.5.

$$I_{CIN} = I_{CHG} \times \sqrt{D \times (1-D)} \quad (5)$$

For SGM41511 place C_{IN} across PMID and GND pins close to the chip. Voltage rating of the capacitor must be at least 25% higher than the normal input voltage to minimize voltage derating. A rating of 25V or higher is preferred for a 15V input voltage.

A $C_{IN} = 22\mu\text{F}$ is suggested for a 3A charger.

Output Capacitor Design

The output capacitance (on the system) must have enough RMS (ripple) current rating to carry the inductor switching ripple and provide enough energy for system transient current demands. I_{COUT} (C_{OUT} RMS current) can be calculated by:

$$I_{COUT} = \frac{I_{RIPPLE}}{2 \times \sqrt{3}} \approx 0.29 \times I_{RIPPLE} \quad (6)$$

And the output voltage ripple can be calculated by:

$$\Delta V_o = \frac{V_{OUT}}{8LC_{OUT}f_s^2} \left(1 - \frac{V_{OUT}}{V_{VBUS}} \right) \quad (7)$$

Increasing L or C_{OUT} (the LC filter) can reduce the ripple.

The charger device has internal loop compensation optimized for above 20 μF ceramic output capacitance. 0V, X7R (or X5R) ceramic capacitors are recommended for the output.

The design is based on buck mode operation that has almost 2.5 times higher current rating (3A) compared to the boost mode (1.2A). The design is sufficient for proper boost operation, because converter is bidirectional and only the direction of currents is reversed.

Input Power Supply Considerations

To power the system from the SGM41511, either an input power source with a voltage between 3.9V to 13.5V and at least 100mA current rating should power V_{BUS} , or a single-cell Li-Ion battery with voltage higher than $V_{BATUVLO}$ should be connected to BAT pin of the device. The input source must have at least 3A current rating to allow maximum power delivery through charger (buck converter) to the system.

APPLICATION INFORMATION (continued)

Layout Guidelines

The switching node (SW) creates very high frequency noises several times higher than f_{sw} (1.5MHz) due to sharp rise and fall times of the voltage and current in the switches. To reduce the ringing issues and noise generation designing a proper layout is important to minimize the current path impedance and loop area. A graphical guideline for the current loops and their frequency content is provided in Figure 20. The following considerations can help making a better layout.

1. Place the input capacitor between PMID and GND pins as close as possible to the chip with shortest copper connections (avoid vias). Choose smallest capacitor sizes.
2. Connect one pin of the inductor as close as possible to the SW pin of the device and minimize the copper area connected to the SW node to reduce capacitive coupling from SW area to nearby signal traces. This decreases the noise induced through parasitic stray capacitances and displacement currents to other conductors. SW connection should be wide enough to carry the charging current. Keep other signals and traces away from SW if possible.
3. Place output capacitor GND pin as close as possible to the GND pin of the device and the GND pin of input capacitor C_{IN} . It is better to avoid using vias for these connections and keep the high frequency current paths very short and on the same

layer. A GND copper layer under the component layer helps reducing noise emissions. Pay attention to the DC current and AC current paths in the layout and keep them short and decoupled as much as possible.

4. For analog signals, it is better to use a separate analog ground (AGND) branched only at one point from GND pin. To avoid high current flow through the AGND path, it should be connected to GND only at one point (preferably the GND pin). Alternatively a 0Ω resistor can be used to tie analog ground to power ground to keep them as separate nets.
5. Place decoupling capacitors close to the IC pins with shortest possible copper connections.
6. Solder the exposed thermal pad of the package to the PCB ground planes. Ensure that there are enough thermal vias directly under the IC, connecting to the ground plane on the other layers for better heat dissipation and cooling of the device.
7. Select proper sizes for the vias and ensure enough copper is available to carry the current for a given current path. Vias usually have some considerable parasitic inductance and resistance.

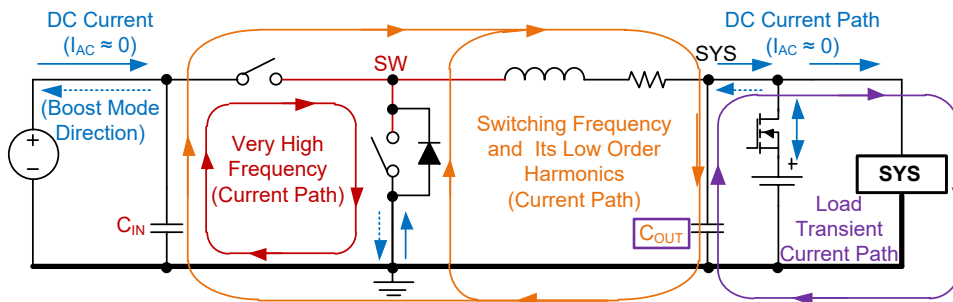

Figure 20. The Paths and Loops Carrying High Frequency, DC Currents and Very High Frequency (for Layout Design Consideration)

REVISION HISTORY

NOTE: Page numbers for previous revisions may differ from page numbers in the current version.

Changes from Original (SEPTEMBER 2019) to REV.A	Page
Changed from product preview to production data.....	All

PACKAGE INFORMATION

PACKAGE OUTLINE DIMENSIONS

TQFN-4×4-24L

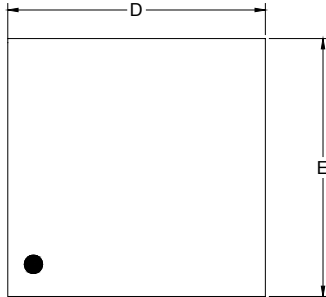

TOP VIEW

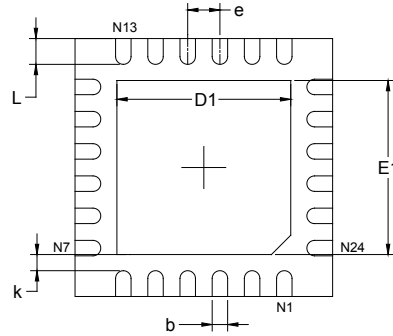

BOTTOM VIEW

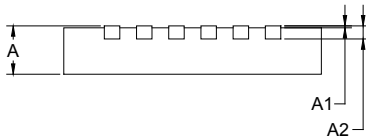

SIDE VIEW

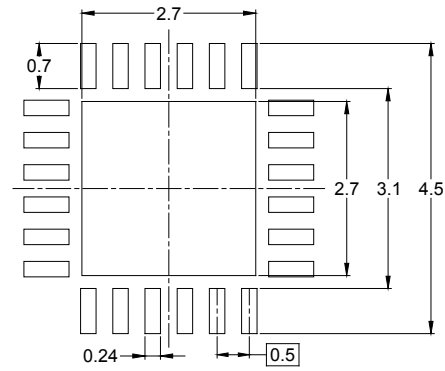

RECOMMENDED LAND PATTERN (Unit: mm)

Symbol	Dimensions In Millimeters		Dimensions In Inches	
	MIN	MAX	MIN	MAX
A	0.700	0.800	0.028	0.031
A1	0.000	0.050	0.000	0.002
A2	0.203 REF		0.008 REF	
D	3.900	4.100	0.154	0.161
D1	2.600	2.800	0.102	0.110
E	3.900	4.100	0.154	0.161
E1	2.600	2.800	0.102	0.110
k	0.200 MIN		0.008 MIN	
b	0.180	0.300	0.007	0.012
e	0.500 TYP		0.020 TYP	
L	0.300	0.500	0.012	0.020

TAPE AND REEL INFORMATION

REEL DIMENSIONS

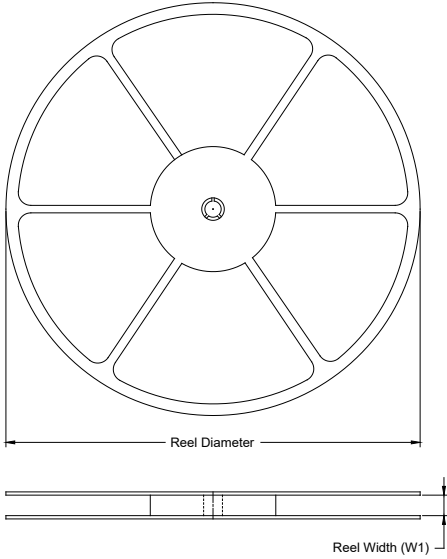

TAPE DIMENSIONS

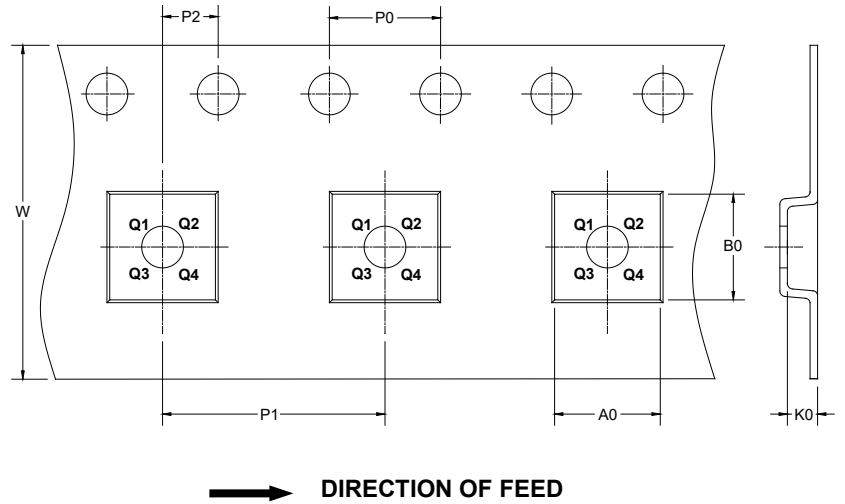

NOTE: The picture is only for reference. Please make the object as the standard.

KEY PARAMETER LIST OF TAPE AND REEL

Package Type	Reel Diameter	Reel Width W1 (mm)	A0 (mm)	B0 (mm)	K0 (mm)	P0 (mm)	P1 (mm)	P2 (mm)	W (mm)	Pin1 Quadrant
TQFN-4x4-24L	13"	12.4	4.30	4.30	1.10	4.0	8.0	2.0	12.0	Q2

DD0001

PACKAGE INFORMATION

CARTON BOX DIMENSIONS



NOTE: The picture is only for reference. Please make the object as the standard.

KEY PARAMETER LIST OF CARTON BOX

Reel Type	Length (mm)	Width (mm)	Height (mm)	Pizza/Carton
13"	386	280	370	5

DD0002