

SGM8771

High Voltage, High Precision, Single Comparator with Voltage Reference

GENERAL DESCRIPTION

The SGM8771 consists of an independent voltage comparator and a 1.225V voltage reference. The device is designed to operate from a single power supply over a wide voltage range, from 2.8V to 36V. Input common mode voltage is 1.5V lower than V_S . Low supply current is independent of the supply voltage. The output can be connected to other open-drain output to achieve wired-AND relationships.

Input offset voltage is 2.4mV (MAX), so the SGM8771 can be used as a precision comparator in application. The 1.225V voltage reference saves external reference and reduces system cost.

The SGM8771 is available in Green SOIC-8 and TDFN-3×3-8L packages. It is operated over the -40°C to +125°C temperature range.

FEATURES

- **Single Supply**
- **Wide Supply Voltage Range: 2.8V to 36V**
- **Internal Voltage Reference: 1.225V**
- **Open-Drain Output**
- **Low Supply Current Independent of Supply Voltage: 180μA (TYP)**
- **Low Input Offset Voltage: 2.4mV (MAX)**
- **Low Input Bias Current: ±20pA (TYP)**
- **Input Common Mode Voltage Range Includes Ground**
- **Differential Input Voltage Range Equal to Maximum-Rated Supply Voltage: ±36V**
- **Low Output Saturation Voltage**
- **Output Compatible with TTL and CMOS**
- **-40°C to +125°C Operating Temperature Range**
- **Available in Green SOIC-8 and TDFN-3×3-8L Packages**

APPLICATIONS

Power System
Battery Monitor
Industrial Control

PACKAGE/ORDERING INFORMATION

MODEL	PACKAGE DESCRIPTION	SPECIFIED TEMPERATURE RANGE	ORDERING NUMBER	PACKAGE MARKING	PACKING OPTION
SGM8771	SOIC-8	-40°C to +125°C	SGM8771XS8G/TR	SGM 8771XS8 XXXXX	Tape and Reel, 4000
	TDFN-3x3-8L	-40°C to +125°C	SGM8771XTDB8G/TR	SGM 8771DB XXXXX	Tape and Reel, 4000

MARKING INFORMATION

NOTE: XXXXX = Date Code, Trace Code and Vendor Code.

XXXXX

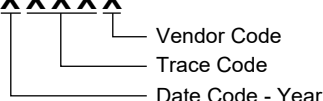

Green (RoHS & HSF): SG Micro Corp defines "Green" to mean Pb-Free (RoHS compatible) and free of halogen substances. If you have additional comments or questions, please contact your SGMICRO representative directly.

ABSOLUTE MAXIMUM RATINGS

Supply Voltage, V_S	40V
Differential Input Voltage, $ V_{ID} $	40V
Input Voltage Range	-0.3V to $(+V_S) + 0.3V$
Output Voltage, V_{OUT}	-0.3V to $(+V_S) + 0.3V$
Output Voltage, V_{REF}	-0.3V to 5.5V
Junction Temperature.....	+150°C
Storage Temperature Range	-65°C to +150°C
Lead Temperature (Soldering, 10s).....	+260°C
ESD Susceptibility	
HBM.....	2000V
CDM	1000V

RECOMMENDED OPERATING CONDITIONS

Operating Temperature Range	-40°C to +125°C
Power Supply Range	2.8V to 36V

OVERSTRESS CAUTION

Stresses beyond those listed in Absolute Maximum Ratings may cause permanent damage to the device. Exposure to absolute maximum rating conditions for extended periods may affect reliability. Functional operation of the device at any conditions beyond those indicated in the Recommended Operating Conditions section is not implied.

ESD SENSITIVITY CAUTION

This integrated circuit can be damaged if ESD protections are not considered carefully. SGMICRO recommends that all integrated circuits be handled with appropriate precautions. Failure to observe proper handling and installation procedures can cause damage. ESD damage can range from subtle performance degradation to complete device failure. Precision integrated circuits may be more susceptible to damage because even small parametric changes could cause the device not to meet the published specifications.

DISCLAIMER

SG Micro Corp reserves the right to make any change in circuit design, or specifications without prior notice.

PIN CONFIGURATIONS

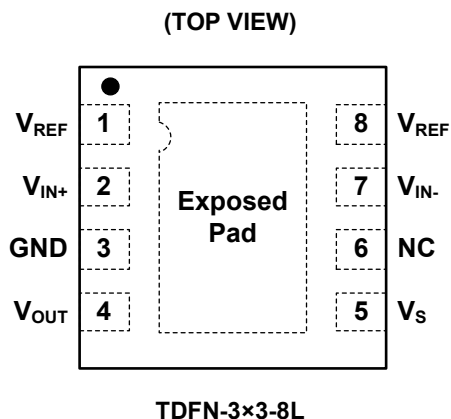
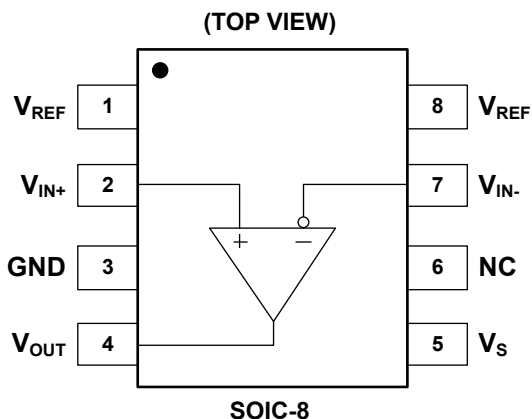

PIN DESCRIPTION

PIN	NAME	FUNCTION
1, 8	V_{REF}	Reference Output.
2	V_{IN+}	Non-Inverting Comparator Input.
3	GND	Ground.
4	V_{OUT}	Comparator Output.
5	V_S	Power Supply.
6	NC	No Connection.
7	V_{IN-}	Inverting Comparator Input.
Exposed Pad	Exposed Pad	Exposed Pad (TDFN-3x3-8L Package Only). Exposed pad should be left floating.

ELECTRICAL CHARACTERISTICS(At $T_A = +25^\circ\text{C}$, $V_S = \pm 1.4\text{V}$ to $\pm 18\text{V}$, Full = -40°C to $+125^\circ\text{C}$, unless otherwise specified.)

PARAMETER	SYMBOL	CONDITIONS	TEMP	MIN	TYP	MAX	UNITS
Input Offset Voltage	V_{OS}	$V_{CM} = 0\text{V}$	+25°C		0.6	2.4	mV
			Full			2.8	
Input Bias Current	I_B	$V_{CM} = 0\text{V}$	+25°C		± 20	± 200	pA
Input Offset Current	I_{OS}	$V_{CM} = 0\text{V}$	+25°C		± 20	± 200	pA
Maximum Differential Input Voltage	$ V_{ID} $		Full			V_S	V
Maximum Input Difference Bias Current	$ I_{ID} $	$V_S = \pm 18\text{V}$, $V_{ID} = \pm 18\text{V}$	+25°C		2.2	4	μA
			Full			5	
Input Common Mode Voltage Range ⁽¹⁾	V_{CM}		Full	$-V_S$		$(+V_S) - 1.5\text{V}$	V
Common Mode Rejection Ratio	CMRR	$V_S = \pm 18\text{V}$, $V_{CM} = (-V_S)$ to $(+V_S) - 1.5\text{V}$	+25°C	90	116		dB
			Full	87			
Power Supply Rejection Ratio	PSRR	$V_S = 2.8\text{V}$ to 36V	+25°C	96	116		dB
			Full	93			
Large-Signal Differential Voltage Amplification	A_{VD}	$V_S = 36\text{V}$, $V_{OUT} = 0.1\text{V}$ to 28.8V , $R_L = 120\text{k}\Omega$ to V_S	+25°C	90	100		dB
			Full	85			
Output Voltage Swing from Rail	V_{OL}	$I_{SINK} = 8\text{mA}$, $V_{ID} = -0.2\text{V}$	+25°C		210	280	mV
			Full			400	
Output Short-Circuit Current	I_{SINK}	$V_{OL} = (-V_S) + 1.5\text{V}$, $V_{ID} = -0.2\text{V}$	+25°C	25	36		mA
High-Level Output Current	I_{OH}	$V_{OH} = 2.8\text{V}$, $V_{ID} = 0.2\text{V}$	+25°C		0.4	0.7	μA
			Full			1	
			+25°C		6	8.5	
			Full			35	
Supply Current	I_S	$I_{OUT} = 0\text{mA}$	+25°C		180	210	μA
			Full			250	
Voltage Reference	V_{REF}	$V_S = 2.8\text{V}$ to 36V , $I_{REF} = 0$ to 5mA	+25°C	1.205	1.225	1.245	V

SWITCHING CHARACTERISTICS(At $T_A = +25^\circ\text{C}$, $V_S = \pm 2.5\text{V}$, $C_L = 15\text{pF}$ ⁽²⁾, unless otherwise noted.)

PARAMETER	SYMBOL	CONDITIONS	TEMP	MIN	TYP	MAX	UNITS
Propagation Delay (High to Low)	t_{PHL}	Overdrive = 10mV	+25°C		85		ns
		Overdrive = 100mV	+25°C		50		ns
Fall Time	t_{FALL}	Overdrive = 10mV	+25°C		12		ns
		Overdrive = 100mV	+25°C		12		ns

NOTES:

- The voltage at either input should not be allowed to be lower than $(-V_S) - 0.3\text{V}$. The upper end of the common mode voltage range is $(+V_S) - 1.5\text{V}$, but either input can go up to 36V without damage.
- C_L includes probe and jig capacitance.

TYPICAL PERFORMANCE CHARACTERISTICS

At $T_A = +25^\circ\text{C}$, $V_S = \pm 18\text{V}$ and $C_L = 15\text{pF}$, unless otherwise noted.

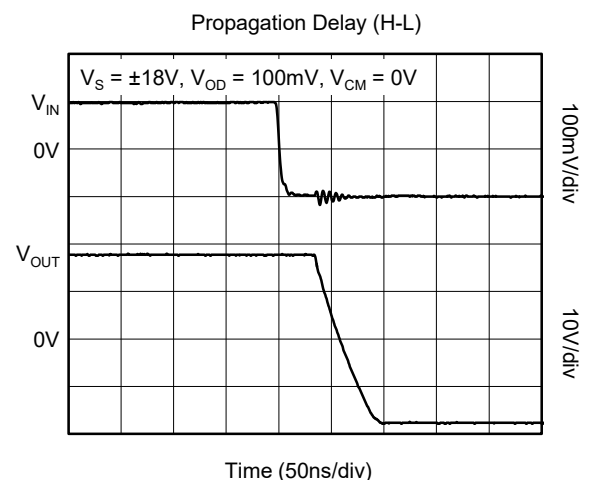
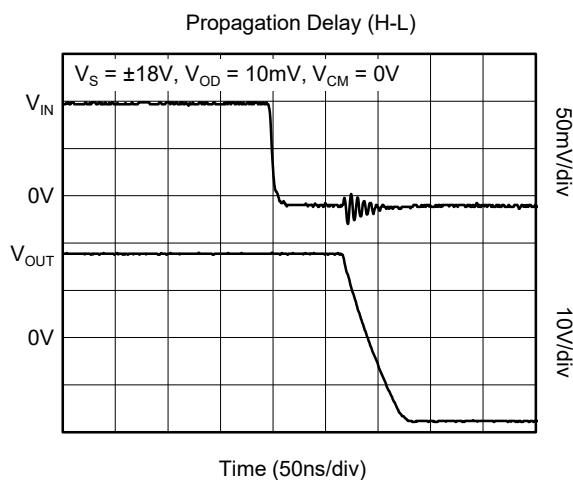
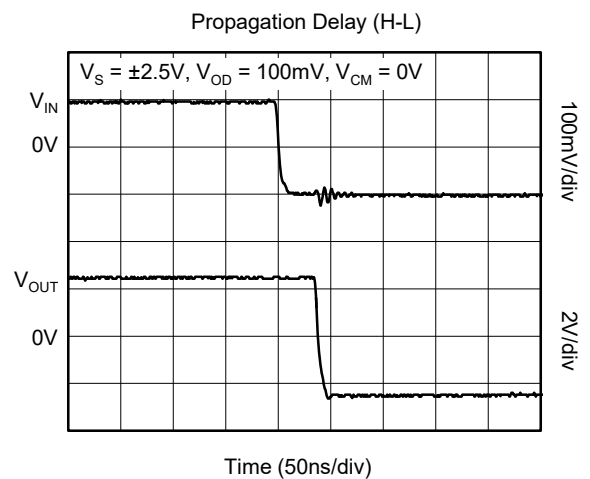
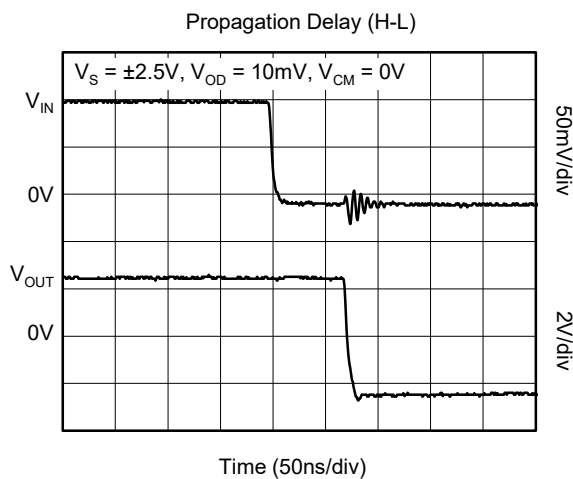
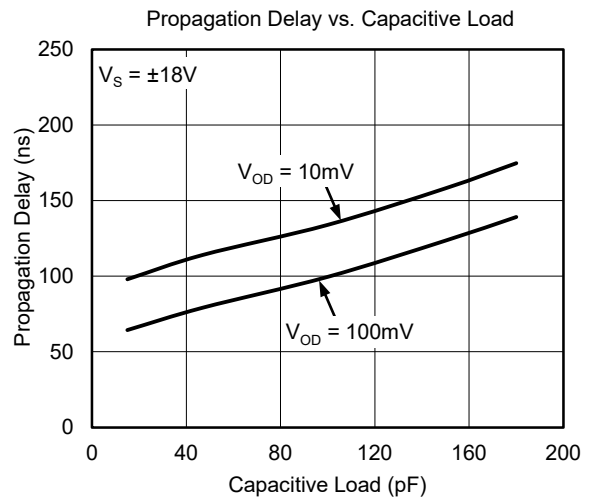
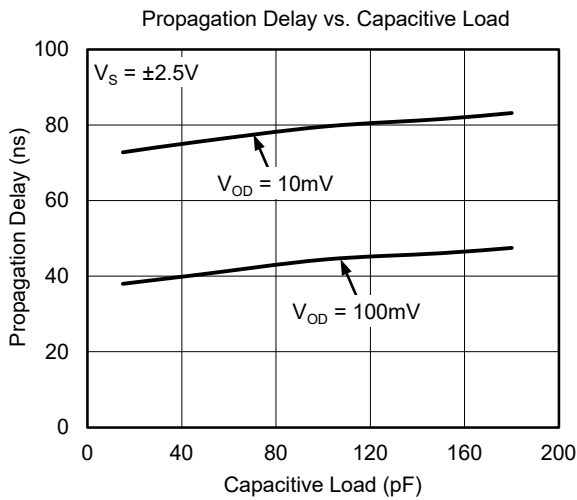

TYPICAL PERFORMANCE CHARACTERISTICS (continued)

At $T_A = +25^\circ\text{C}$, $V_S = \pm 18\text{V}$ and $C_L = 15\text{pF}$, unless otherwise noted.

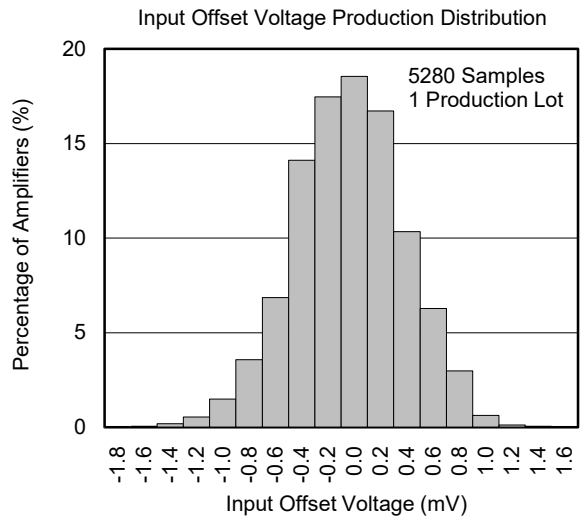
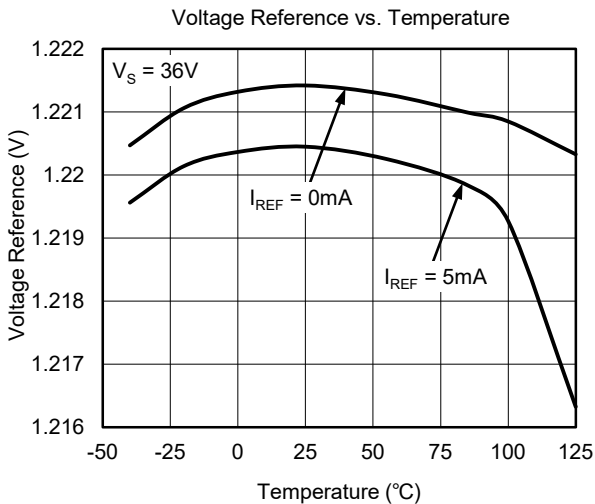
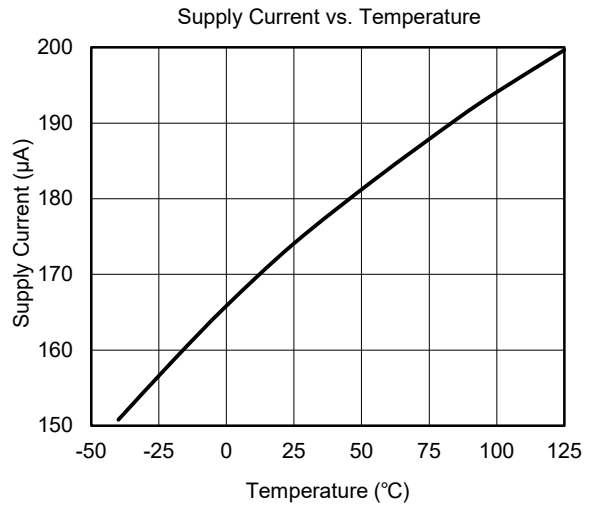
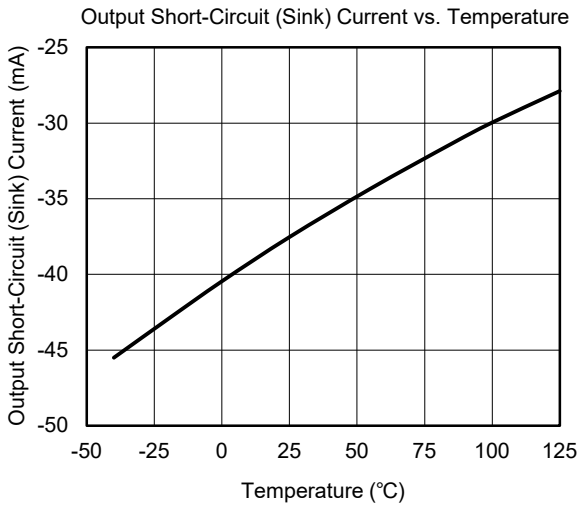
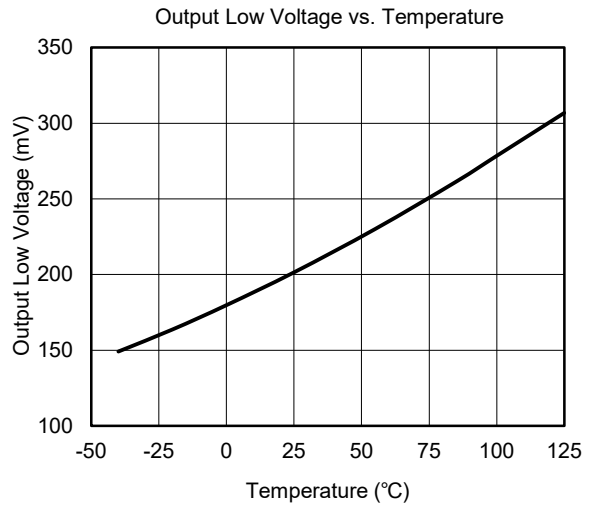
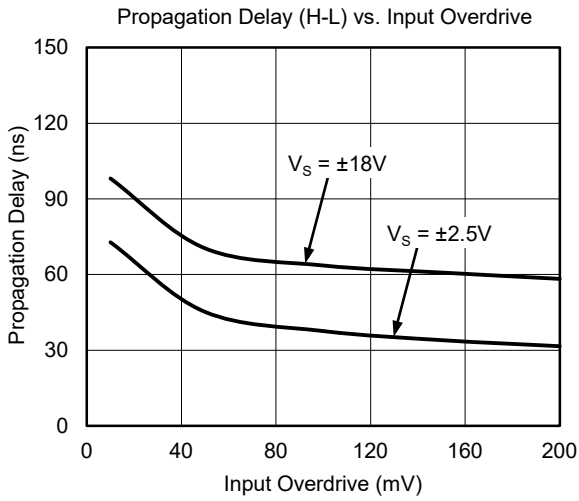

DETAILED DESCRIPTION

The SGM8771 includes a single comparator that features high precision and low power. Open-drain structure needs external pull-up resistor. The wide input voltage range and power supply range make the device ideal for industrial equipment. The SGM8771 can interface directly with CMOS and TTL logics.

Output Stage Circuitry

The SGM8771 contains an open-drain current-driven output stage as shown in Figure 1. During an output transition, I_{SINK} pulls output pin to logic low. The output sink current is larger during the transition, creating a high slew rate. Once the output voltage reaches V_{OL} , the sink current will decrease to a small value, capable of maintaining the V_{OL} static condition. This significant decrease in current conserves power after an output transition has occurred.

One consequence of a current-driven output stage is a linear dependence between the slew rate and the load

capacitance. A heavy capacitive load will slow down a voltage output transition. This can be useful in noise-sensitive applications where fast edges may cause interference.

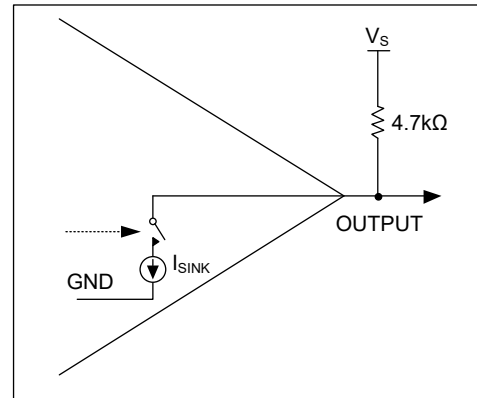

Figure 1. Open-Drain Output Stage Circuitry

APPLICATION INFORMATION

Circuit Layout and Bypassing

The SGM8771 requires design precautions to realize the full high-speed capabilities of the comparator. The recommended precautions are:

- 1) Use the PCB with a good, unbroken, low-inductance ground plane.
- 2) Place a decoupling capacitor (a 0.1μF ceramic capacitor is a good choice) as close to V_S as possible.

- 3) Pay close attention to the decoupling capacitor's bandwidth, keeping leads short.
- 4) On the inputs and output, keep lead lengths short to avoid unwanted parasitic feedback around the comparator.
- 5) Solder the device directly to the PCB instead of using a socket.

REVISION HISTORY

NOTE: Page numbers for previous revisions may differ from page numbers in the current version.

Changes from Original (DECEMBER 2019) to REV.A	Page
Changed from product preview to production data.....	All

PACKAGE OUTLINE DIMENSIONS

SOIC-8

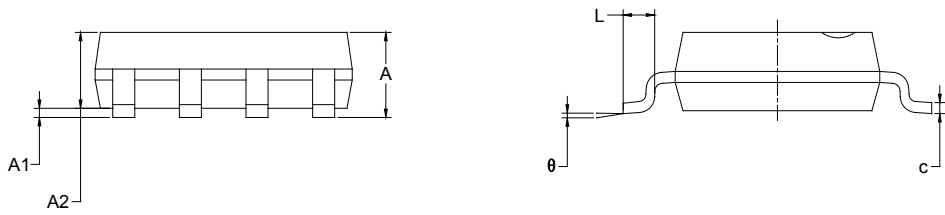
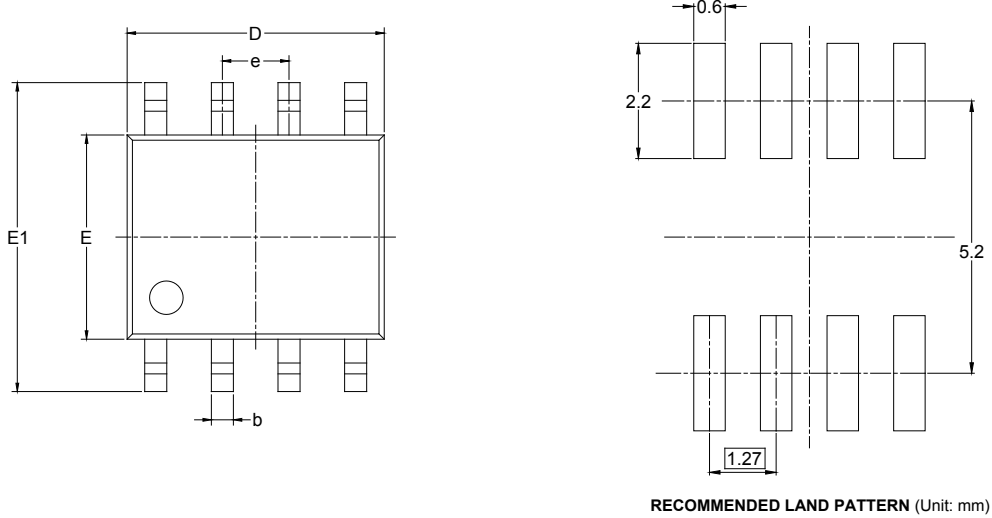

Symbol	Dimensions In Millimeters		Dimensions In Inches	
	MIN	MAX	MIN	MAX
A	1.350	1.750	0.053	0.069
A1	0.100	0.250	0.004	0.010
A2	1.350	1.550	0.053	0.061
b	0.330	0.510	0.013	0.020
c	0.170	0.250	0.006	0.010
D	4.700	5.100	0.185	0.200
E	3.800	4.000	0.150	0.157
E1	5.800	6.200	0.228	0.244
e	1.27 BSC		0.050 BSC	
L	0.400	1.270	0.016	0.050
θ	0°	8°	0°	8°

PACKAGE INFORMATION

PACKAGE OUTLINE DIMENSIONS

TDFN-3x3-8L

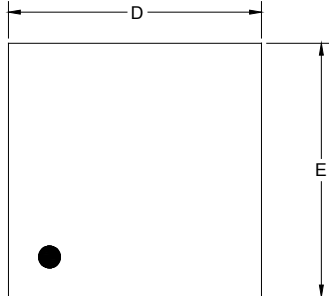

TOP VIEW

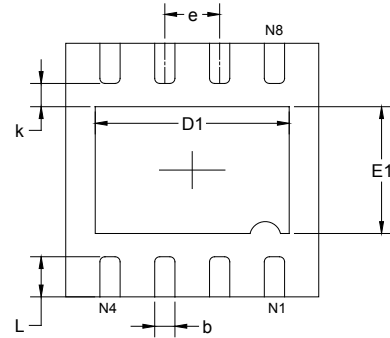

BOTTOM VIEW

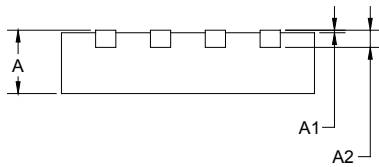

SIDE VIEW

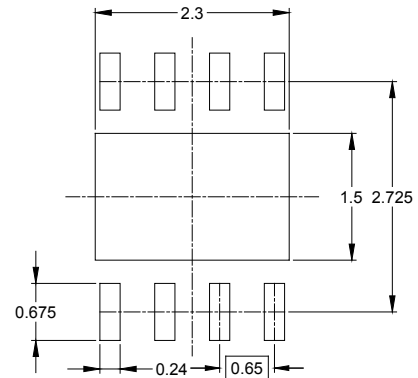

RECOMMENDED LAND PATTERN (Unit: mm)

Symbol	Dimensions In Millimeters		Dimensions In Inches	
	MIN	MAX	MIN	MAX
A	0.700	0.800	0.028	0.031
A1	0.000	0.050	0.000	0.002
A2	0.203 REF		0.008 REF	
D	2.900	3.100	0.114	0.122
D1	2.200	2.400	0.087	0.094
E	2.900	3.100	0.114	0.122
E1	1.400	1.600	0.055	0.063
k	0.200 MIN		0.008 MIN	
b	0.180	0.300	0.007	0.012
e	0.650 TYP		0.026 TYP	
L	0.375	0.575	0.015	0.023

PACKAGE INFORMATION

TAPE AND REEL INFORMATION

REEL DIMENSIONS

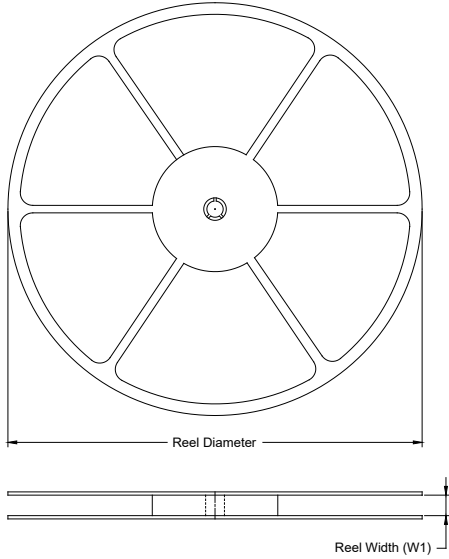

TAPE DIMENSIONS

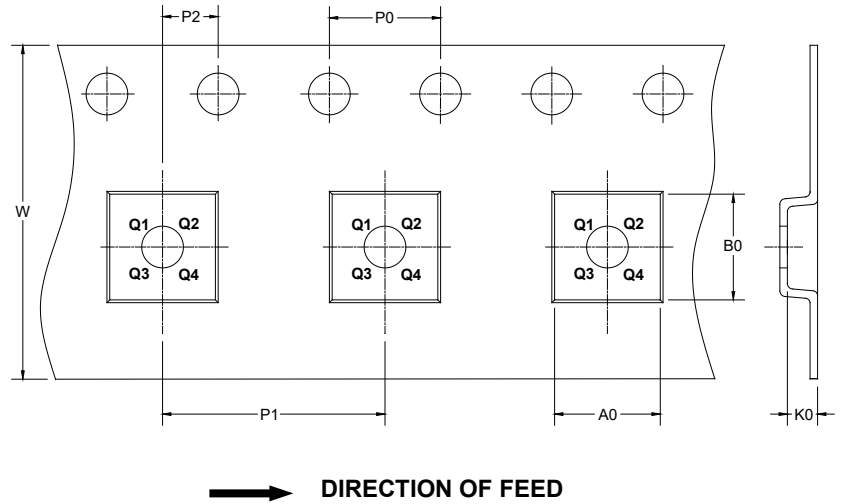

NOTE: The picture is only for reference. Please make the object as the standard.

KEY PARAMETER LIST OF TAPE AND REEL

Package Type	Reel Diameter	Reel Width W1 (mm)	A0 (mm)	B0 (mm)	K0 (mm)	P0 (mm)	P1 (mm)	P2 (mm)	W (mm)	Pin1 Quadrant
SOIC-8	13"	12.4	6.40	5.40	2.10	4.0	8.0	2.0	12.0	Q1
TDFN-3×3-8L	13"	12.4	3.35	3.35	1.13	4.0	8.0	2.0	12.0	Q1

DD0001

PACKAGE INFORMATION

CARTON BOX DIMENSIONS



NOTE: The picture is only for reference. Please make the object as the standard.

KEY PARAMETER LIST OF CARTON BOX

Reel Type	Length (mm)	Width (mm)	Height (mm)	Pizza/Carton
13"	386	280	370	5

DD0002