

# MM74HC14

## Hex Inverting Schmitt Trigger

### Features

- Typical propagation delay: 13ns
- Wide power supply range: 2V–6V
- Low quiescent current: 20µA maximum (74HC Series)
- Low input current: 1µA maximum
- Fanout of 10 LS-TTL loads
- Typical hysteresis voltage: 0.9V at  $V_{CC} = 4.5V$

### General Description

The MM74HC14 utilizes advanced silicon-gate CMOS technology to achieve the low power dissipation and high noise immunity of standard CMOS, as well as the capability to drive 10 LS-TTL loads.

The 74HC logic family is functionally and pinout compatible with the standard 74LS logic family. All inputs are protected from damage due to static discharge by internal diode clamps to  $V_{CC}$  and ground.

### Ordering Information

Order Number	Package Number	Package Description
MM74HC14M	M14A	14-Lead Small Outline Integrated Circuit (SOIC), JEDEC MS-012, 0.150" Narrow
MM74HC14SJ	M14D	14-Lead Small Outline Package (SOP), EIAJ TYPE II, 5.3mm Wide
MM74HC14MTC	MTC14	14-Lead Thin Shrink Small Outline Package (TSSOP), JEDEC MO-153, 4.4mm Wide
MM74HC14N	N14A	14-Lead Plastic Dual-In-Line Package (PDIP), JEDEC MS-001, 0.300" Wide

Device also available in Tape and Reel. Specify by appending suffix letter "X" to the ordering number.

 All packages are lead free per JEDEC: J-STD-020B standard.

### Connection Diagram

Pin Assignments for DIP, SOIC, SOP and TSSOP

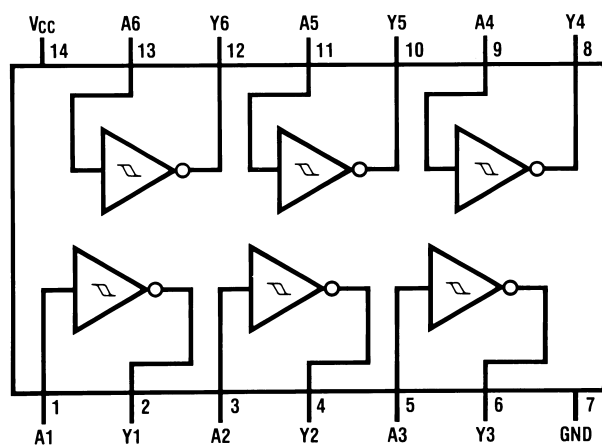

Top View

### Logic Diagram

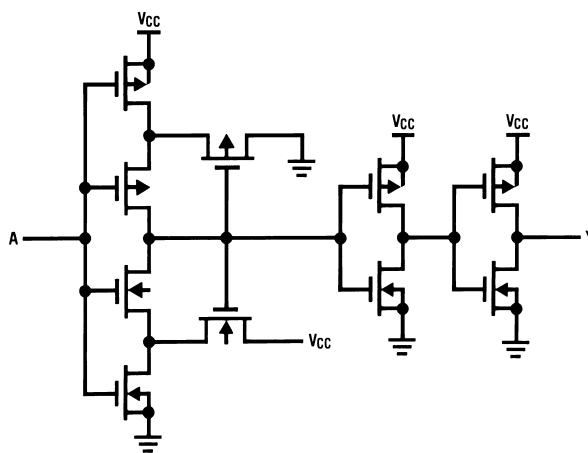

## Absolute Maximum Ratings<sup>(1)</sup>

Stresses exceeding the absolute maximum ratings may damage the device. The device may not function or be operable above the recommended operating conditions and stressing the parts to these levels is not recommended. In addition, extended exposure to stresses above the recommended operating conditions may affect device reliability. The absolute maximum ratings are stress ratings only.

Symbol	Parameter	Rating
$V_{CC}$	Supply Voltage	-0.5 to +7.0V
$V_{IN}$	DC Input Voltage	-1.5 to $V_{CC}+1.5V$
$V_{OUT}$	DC Output Voltage	-0.5 to $V_{CC}+0.5V$
$I_{IK}, I_{OK}$	Clamp Diode Current	$\pm 20mA$
$I_{OUT}$	DC Output Current, per pin	$\pm 25mA$
$I_{CC}$	DC $V_{CC}$ or GND Current, per pin	$\pm 50mA$
$T_{STG}$	Storage Temperature Range	-65°C to +150°C
$P_D$	Power Dissipation Note 2	600mW
	S.O. Package only	500mW
$T_L$	Lead Temperature (Soldering 10 seconds)	260°C

### Notes:

1. Unless otherwise specified all voltages are referenced to ground.
2. Power Dissipation temperature derating — plastic “N” package: -12mW/°C from 65°C to 85°C.

## Recommended Operating Conditions

The Recommended Operating Conditions table defines the conditions for actual device operation. Recommended operating conditions are specified to ensure optimal performance to the datasheet specifications. ON Semiconductor does not recommend exceeding them or designing to absolute maximum ratings.

Symbol	Parameter	Min.	Max.	Units
$V_{CC}$	Supply Voltage	2	6	V
$V_{IN}, V_{OUT}$	DC Input or Output Voltage	0	$V_{CC}$	V
$T_A$	Operating Temperature Range	-55	+125	°C

DC Electrical Characteristics<sup>(3)</sup>

Symbol	Parameter	V <sub>CC</sub> (V)	Conditions	T <sub>A</sub> = 25°C		T <sub>A</sub> = -40°C to 85°C	T <sub>A</sub> = -55°C to 125°C	Units
				Typ.	Guaranteed Limits			
V <sub>T+</sub>	Positive Going Threshold Voltage	2.0	Minimum	1.2	1.0	1.0	1.0	V
				2.7	2.0	2.0	2.0	
				3.2	3.0	3.0	3.0	
		4.5	Maximum	1.2	1.5	1.5	1.5	
				2.7	3.15	3.15	3.15	
				3.2	4.2	4.2	4.2	
V <sub>T-</sub>	Negative Going Threshold Voltage	2.0	Minimum	0.7	0.3	0.3	0.3	V
				1.8	0.9	0.9	0.9	
				2.2	1.2	1.2	1.2	
		4.5	Maximum	0.7	1.0	1.0	1.0	
				1.8	2.2	2.2	2.2	
				2.2	3.0	3.0	3.0	
V <sub>H</sub>	Hysteresis Voltage	2.0	Minimum	0.5	0.2	0.2	0.2	V
				0.9	0.4	0.4	0.4	
				1.0	0.5	0.5	0.5	
		4.5	Maximum	0.5	1.0	1.0	1.0	
				0.9	1.4	1.4	1.4	
				1.0	1.5	1.5	1.5	
V <sub>OH</sub>	Minimum HIGH Level Output Voltage	2.0	V <sub>IN</sub> = V <sub>IL</sub> ,  I <sub>OUT</sub>   = 20μA	2.0	1.9	1.9	1.9	V
		4.5		4.5	4.4	4.4	4.4	
		6.0		6.0	5.9	5.9	5.9	
		4.5	V <sub>IN</sub> = V <sub>IL</sub> ,  I <sub>OUT</sub>   = 4.0mA	4.2	3.98	3.84	3.7	
		6.0	V <sub>IN</sub> = V <sub>IL</sub> ,  I <sub>OUT</sub>   = 5.2mA	5.7	5.48	5.34	5.2	
V <sub>OL</sub>	Maximum LOW Level Output Voltage	2.0	V <sub>IN</sub> = V <sub>IH</sub> ,  I <sub>OUT</sub>   = 20μA	0	0.1	0.1	0.1	V
		4.5		0	0.1	0.1	0.1	
		6.0		0	0.1	0.1	0.1	
		4.5	V <sub>IN</sub> = V <sub>IH</sub> ,  I <sub>OUT</sub>   = 4.0mA	0.2	0.26	0.33	0.4	
		6.0	V <sub>IN</sub> = V <sub>IH</sub> ,  I <sub>OUT</sub>   = 5.2mA	0.2	0.26	0.33	0.4	
I <sub>IN</sub>	Maximum Input Current	6.0	V <sub>IN</sub> = V <sub>CC</sub> or GND		±0.1	±1.0	±1.0	μA
I <sub>CC</sub>	Maximum Quiescent Supply Current	6.0	V <sub>IN</sub> = V <sub>CC</sub> or GND, I <sub>OUT</sub> = 0μA		2.0	20	40	μA

**Note:**

3. For a power supply of 5V ±10% the worst case output voltages (V<sub>OH</sub>, and V<sub>OL</sub>) occur for HC at 4.5V. Thus the 4.5V values should be used when designing with this supply. Worst case V<sub>IH</sub> and V<sub>IL</sub> occur at V<sub>CC</sub> = 5.5V and 4.5V respectively. (The V<sub>IH</sub> value at 5.5V is 3.85V.) The worst case leakage current (I<sub>IN</sub>, I<sub>CC</sub>, and I<sub>OZ</sub>) occur for CMOS at the higher voltage and so the 6.0V values should be used.

**AC Electrical Characteristics** $V_{CC} = 5V$ ,  $T_A = 25^\circ C$ ,  $C_L = 15pF$ ,  $t_r = t_f = 6ns$ 

Symbol	Parameter	Conditions	Typ.	Guaranteed Limit	Units
$t_{PHL}$ , $t_{PLH}$	Maximum Propagation Delay		12	22	ns

**AC Electrical Characteristics** $V_{CC} = 2.0V$  to  $6.0V$ ,  $C_L = 50pF$ ,  $t_r = t_f = 6ns$  (unless otherwise specified)

Symbol	Parameter	$V_{CC}$ (V)	Conditions	$T_A = 25^\circ C$		$T_A = -40^\circ C$ to $85^\circ C$	$T_A = -55^\circ C$ to $125^\circ C$	Units
				Typ.	Guaranteed Limits			
$t_{PHL}$ , $t_{PLH}$	Maximum Propagation Delay	2.0		60	125	156	188	ns
		4.5		13	25	31	38	
		6.0		11	21	26	32	
$t_{TLH}$ , $t_{THL}$	Maximum Output Rise and Fall Time	2.0		30	75	95	110	ns
		4.5		8	15	19	22	
		6.0		7	13	16	19	
$C_{PD}$	Power Dissipation Capacitance <sup>(4)</sup>		(per gate)	27				pF
$C_{IN}$	Maximum Input Capacitance			5	10	10	10	pF

**Note:**

4.  $C_{PD}$  determines the no load dynamic power consumption,  $P_D = C_{PD} V_{CC}^2 f + I_{CC} V_{CC}$ , and the no load dynamic current consumption,  $I_S = C_{PD} V_{CC} f + I_{CC}$ .

## Typical Performance Characteristics

Input Threshold,  $V_{T+}$ ,  $V_{T-}$ , vs Power Supply Voltage

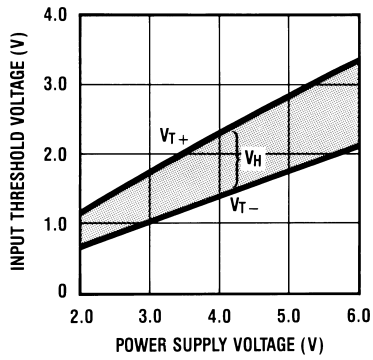

Propagation Delay vs. Power Supply

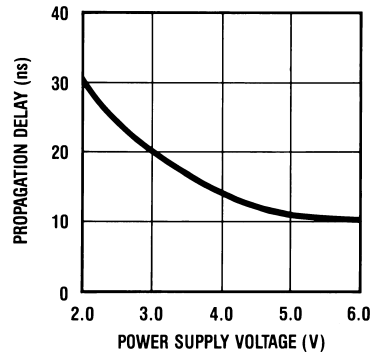

## Typical Applications

Low Power Oscillator

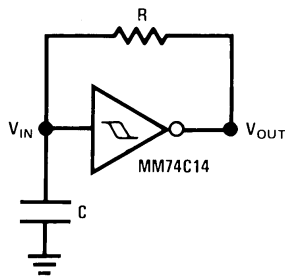

$$t_1 \approx RC \ln \frac{V_{T+}}{V_{T-}}$$

$$t_2 \approx RC \ln \frac{V_{CC} - V_{T-}}{V_{CC} - V_{T+}}$$

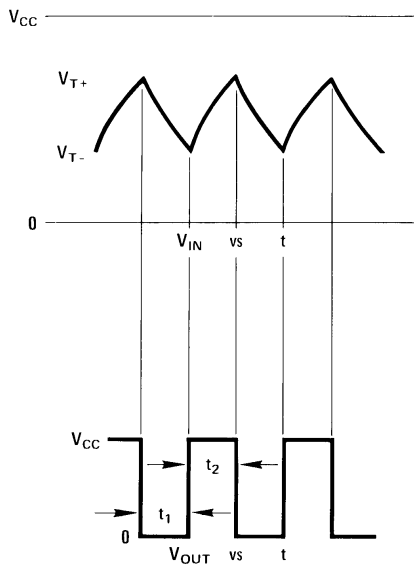

$$f \approx \frac{1}{RC \ln \frac{V_{T+}(V_{CC} - V_{T-})}{V_{T-}(V_{CC} - V_{T+})}}$$

**Note:**

The equations assume  $t_1 + t_2 \gg t_{pd0} + t_{pd1}$