

SGM2528

5A, 12V Electronic Fuse (eFuse) with Thermal Shutdown

GENERAL DESCRIPTION

The SGM2528 is a compact electronic fuse (eFuse) with a complete set of protection functions. The wide operating voltage range is specifically designed for many popular DC buses. The SGM2528 provides excellent accuracy, making it very suitable for many system protection applications.

It provides accurate over-voltage (OV) and under-voltage lockout (UVLO) protections, which ensure tight supervision of bus voltages and eliminate the need for supervisor circuits. The over-voltage (OV) protection will clamp the eFuse output at a fixed level during input voltage surges. During the input voltage transient, the internal FET remains on, which allows the load to continue to operate. If the transient duration remains long, the accumulated heat will cause the eFuse thermal shutdown. Once in thermal shutdown, latch-off and auto-retry thermal options are available.

The SGM2528 is available in a Green TDFN-3×3-10L package.

FEATURES

- **Wide Input Voltage Range from 9V to 18V with Surge up to 30V**
- **Extremely Low $R_{DS(ON)}$ for the Integrated Protection Switch: 26m Ω (TYP)**
- **3-State ENABLE/FAULT Pin, Bidirectional Interface**
- **Programmable Soft-Start Time**
- **Programmable Current Limit up to 5A**
- **Thermal Shutdown Options:**
 - ◆ **SGM2528A: Thermal Latch-Off with V_{CLAMP}**
 - ◆ **SGM2528B: Thermal Auto-Retry with V_{CLAMP}**
 - ◆ **SGM2528C: Thermal Latch-Off without V_{CLAMP}**
- **Fault Output for Thermal Shutdown**
- **Accurate Under-Voltage Lockout**
- **Accurate Over-Voltage Clamp (SGM2528A and SGM2528B)**
- **Available in a Green TDFN-3×3-10L Package**

APPLICATIONS

Hard Drives

PCIE SSD

Motherboard Power Management

PACKAGE/ORDERING INFORMATION

MODEL	PACKAGE DESCRIPTION	SPECIFIED TEMPERATURE RANGE	ORDERING NUMBER	PACKAGE MARKING	PACKING OPTION
SGM2528A	TDFN-3×3-10L	-40°C to +125°C	SGM2528AXTD10G/TR	SGM 2528AD XXXXX	Tape and Reel, 4000
SGM2528B	TDFN-3×3-10L	-40°C to +125°C	SGM2528BXTD10G/TR	SGM 2528BD XXXXX	Tape and Reel, 4000
SGM2528C	TDFN-3×3-10L	-40°C to +125°C	SGM2528CXTD10G/TR	SGM 2528CD XXXXX	Tape and Reel, 4000

MARKING INFORMATION

NOTE: XXXXX = Date Code, Trace Code and Vendor Code.

XXXXX

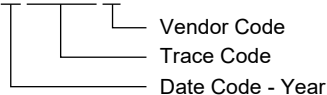

Green (RoHS & HSF): SG Micro Corp defines "Green" to mean Pb-Free (RoHS compatible) and free of halogen substances. If you have additional comments or questions, please contact your SGMICRO representative directly.

ABSOLUTE MAXIMUM RATINGS

- Operating Input Voltage Range (V_{CC} to GND) ⁽¹⁾
 - Steady-State -0.3V to 18V
 - Transient (100ms) -0.6V to 25V
- V_{CC} , SOURCE, I_{LIMIT} to GND -0.3V to 25V
- dV/dt, ENABLE/FAULT to GND -0.3V to 5.5V
- Package Thermal Resistance
 - TDFN-3×3-10L, θ_{JA} 90°C/W
 - TDFN-3×3-10L, θ_{JB} 54°C/W
 - TDFN-3×3-10L, θ_{JC} 52°C/W
- Junction Temperature +150°C
- Storage Temperature Range -65°C to +150°C
- Lead Temperature (Soldering, 10s) +260°C
- ESD Susceptibility
 - HBM 2000V
 - CDM 1000V

NOTE: 1. Negative voltage will not damage device provided that the power dissipation is limited to the rated allowable power for the package.

RECOMMENDED OPERATING CONDITIONS

Operating Junction Temperature Range -40°C to +125°C

OVERSTRESS CAUTION

Stresses beyond those listed in Absolute Maximum Ratings may cause permanent damage to the device. Exposure to absolute maximum rating conditions for extended periods may affect reliability. Functional operation of the device at any conditions beyond those indicated in the Recommended Operating Conditions section is not implied.

ESD SENSITIVITY CAUTION

This integrated circuit can be damaged if ESD protections are not considered carefully. SGMICRO recommends that all integrated circuits be handled with appropriate precautions. Failure to observe proper handling and installation procedures can cause damage. ESD damage can range from subtle performance degradation to complete device failure. Precision integrated circuits may be more susceptible to damage because even small parametric changes could cause the device not to meet the published specifications.

DISCLAIMER

SG Micro Corp reserves the right to make any change in circuit design, or specifications without prior notice.

PIN CONFIGURATION

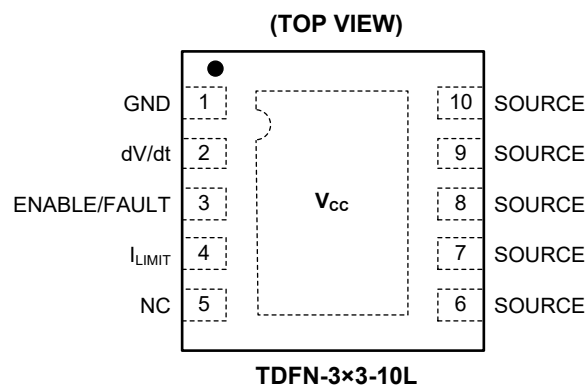

PIN DESCRIPTION

PIN	NAME	FUNCTION
1	GND	Ground.
2	dV/dt	Internal dV/dt Circuit. Leaving this pin open will allow the device to ramp up in 2ms. An external capacitor between this pin and GND will set the slew rate according to the application requirements.
3	ENABLE/ FAULT	Enable or Fault Pin. This pin is a 3-state, bidirectional interface. Asserting ENABLE/FAULT pin high enables the device. When the thermal shutdown occurs, the device sinks current from ENABLE/FAULT, and pulls the pin low to alert the host (this pin is used as output port).
4	I_{LIMIT}	Current Limit Pin. This pin is used to set the overload and short-circuit current limit levels by placing a resistor.
5	NC	No Connection.
6 - 10	SOURCE	Power Output Pins.
Exposed Pad	V_{CC}	Power Input Pin. Power input and supply voltage of the device.

ELECTRICAL CHARACTERISTICS(T_J = +25°C, V_{CC} = 12V and dV/dt pin is open, unless otherwise noted.)

PARAMETER	SYMBOL	CONDITIONS	MIN	TYP	MAX	UNITS
Power FET						
Delay Time	t _{DLY}	Enabling of chip to I _D = 100mA with 1A resistive load		386		μs
Kelvin On-Resistance	R _{DS(ON)}	T _J = +25°C	21	26	31	mΩ
		T _J = +135°C		38		
Off-State Output Voltage	V _{OFF}	V _{CC} = 18V, V _{GS} = 0V, R _L = ∞		20	200	mV
Continuous Current	I _D			5		A
Thermal Latch						
Shutdown Temperature	T _{SD}			158		°C
Thermal Hysteresis	T _{HYST}	Decrease in die temperature for turn-on; does not apply to latch-off options.		22		°C
Under/Over-Voltage Protection						
Output Clamping Voltage	V _{CLAMP}	Over-voltage protection, V _{CC} = 18V	14.5	15	15.5	V
Under-Voltage Lockout	V _{UVLO}	Turn on, voltage going high	8.2	8.5	8.8	V
UVLO Hysteresis	V _{HYST}			0.83		V
Current Limit						
Kelvin Short-Circuit Current Limit	I _{LIM-SC}	R _{LIMIT} = 77Ω	0.5	0.95	1.4	A
Kelvin Overload Current Limit	I _{LIM-OL}	R _{LIMIT} = 77Ω		3		A
dV/dt Circuit						
Output Voltage Ramp Time	t _{SLEW}	Enable to V _{OUT} = 11.7V	1.3	2	2.8	ms
Maximum Capacitor Voltage	V _{MAX}				5.3	V
ENABLE/FAULT Pin						
Logic Level Low	V _{IN-LOW}	Output disabled	0.45	0.55	0.65	V
Logic Level Mid	V _{IN-MID}	Thermal fault, output disabled	1.35	1.45	1.55	V
Logic Level High	V _{IN-HIGH}	Output enabled	2.5	2.62	2.75	V
High State Maximum Voltage	V _{IN-MAX}		4.9	5.1	5.3	V
Logic Low Sink Current	I _{IN-LOW}	V _{ENABLE} = 0V		-15	-22	μA
Power Supply						
Quiescent Current	I _Q	Operating		110	140	μA
		Shutdown		48		

TYPICAL PERFORMANCE CHARACTERISTICS

T_J = +25°C, unless otherwise noted.

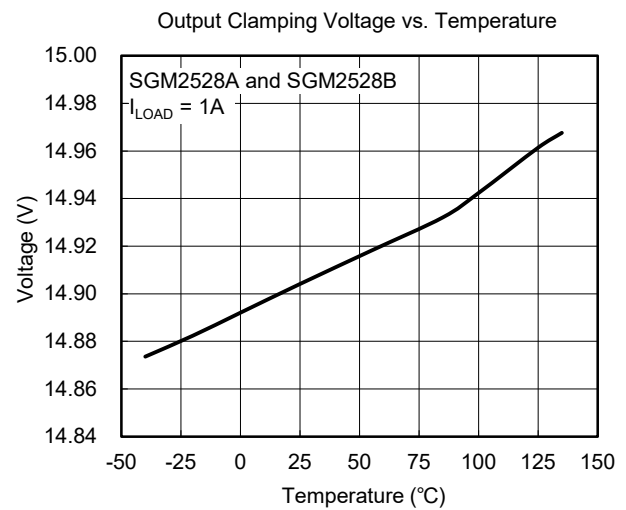
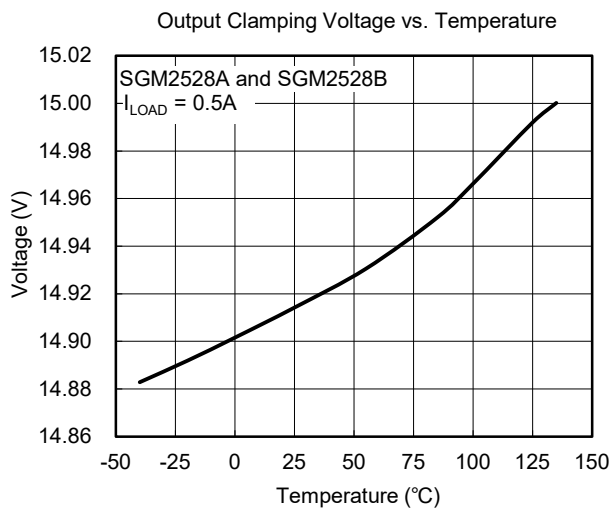
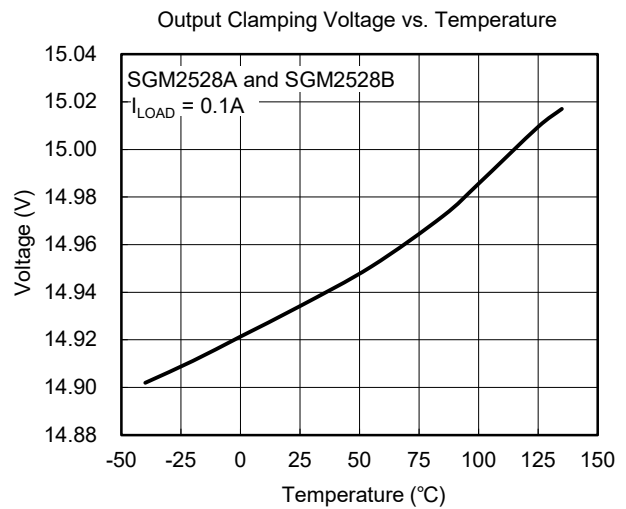
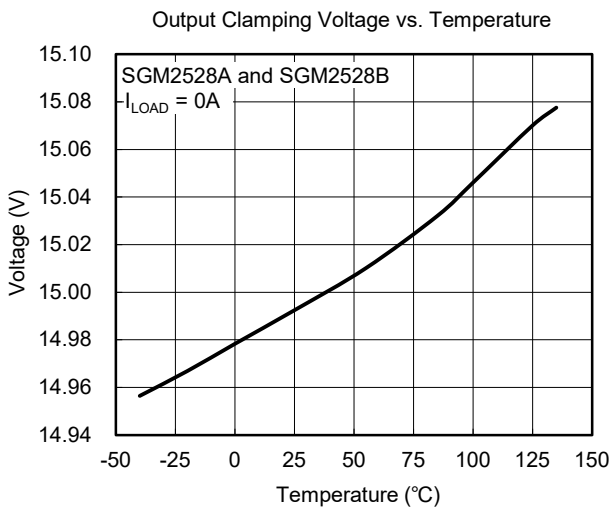
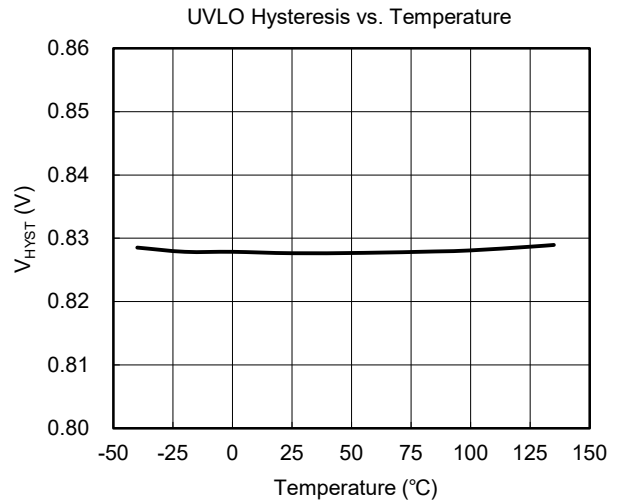
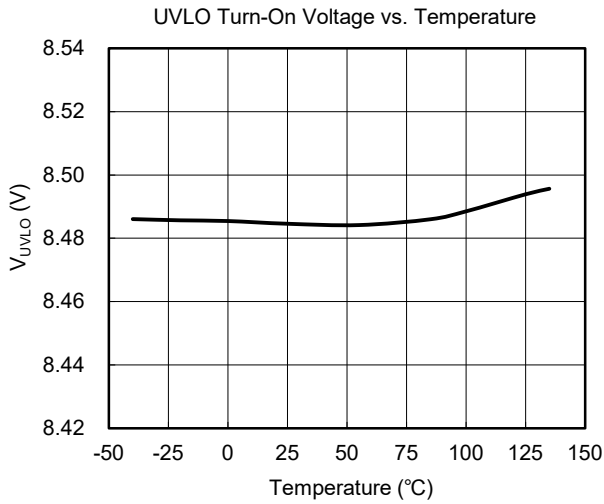

TYPICAL PERFORMANCE CHARACTERISTICS (continued)

T_J = +25°C, unless otherwise noted.

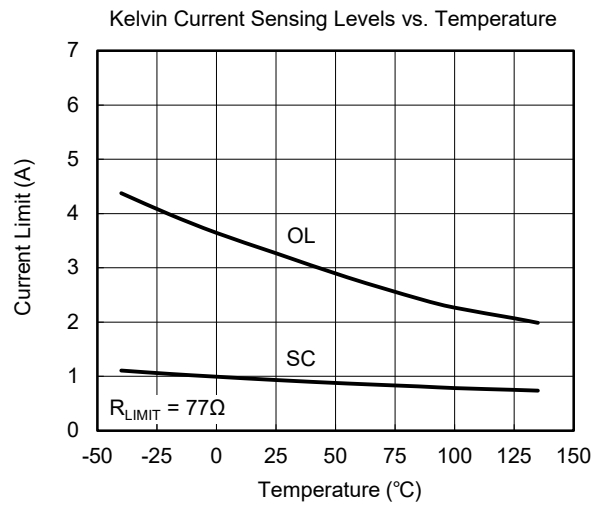
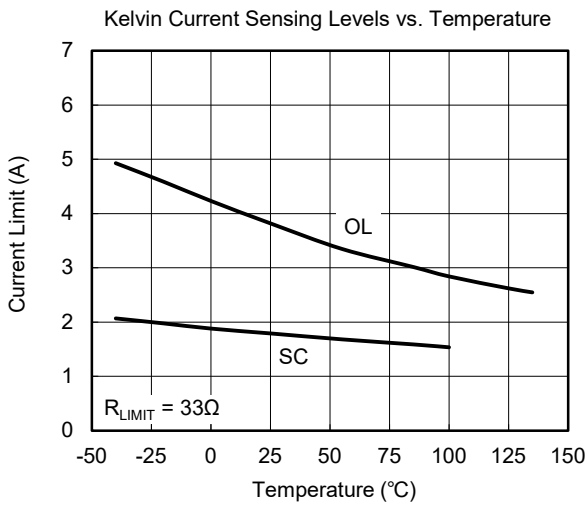
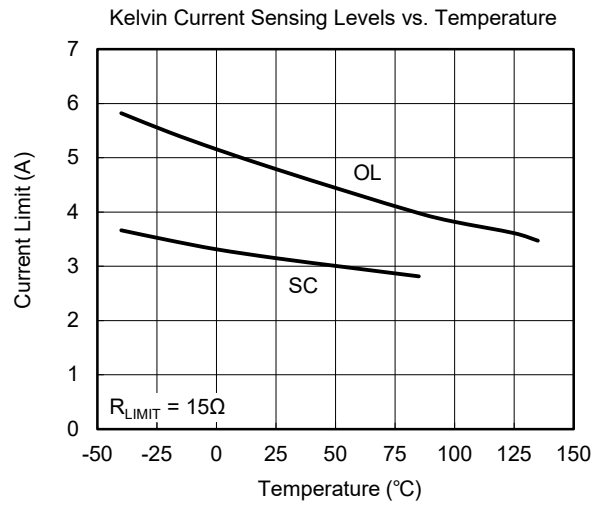
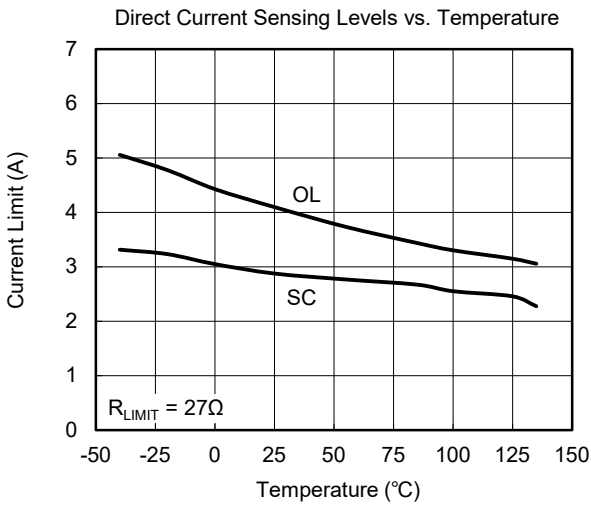
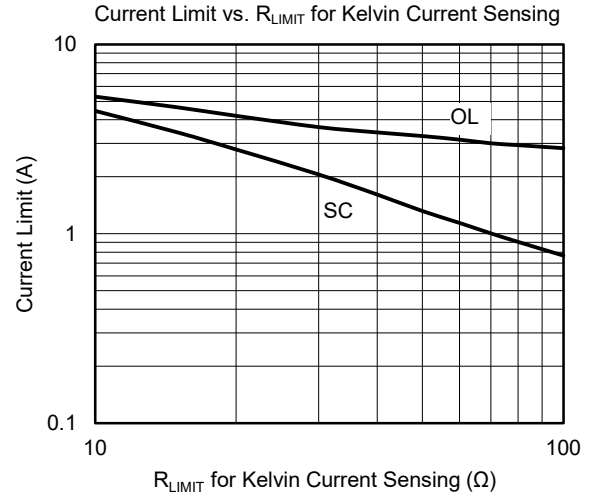
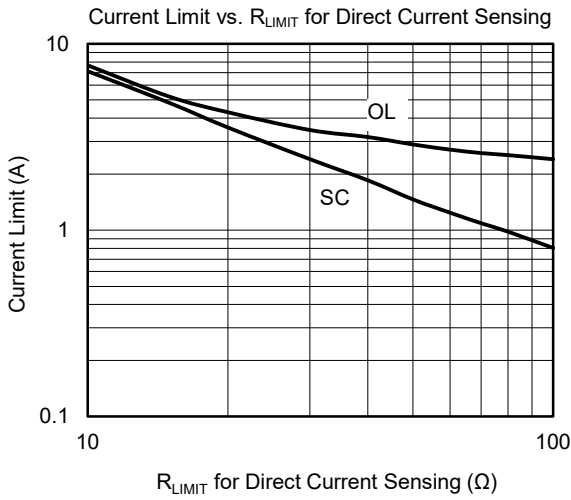

TYPICAL PERFORMANCE CHARACTERISTICS (continued)

T_J = +25°C, unless otherwise noted.

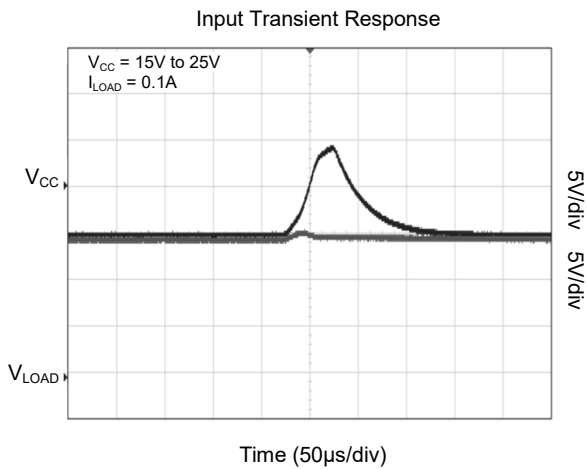
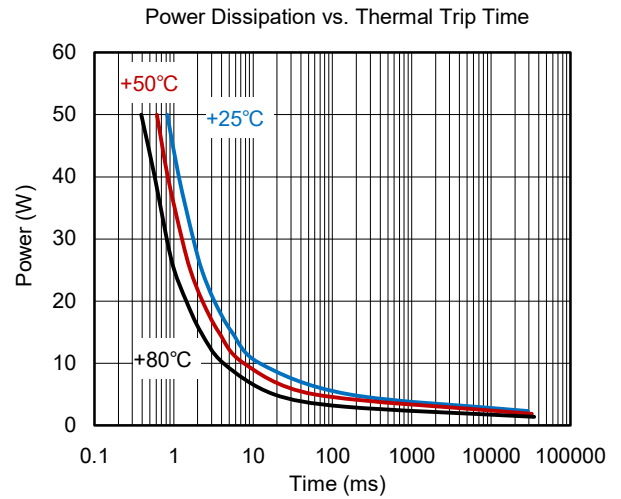
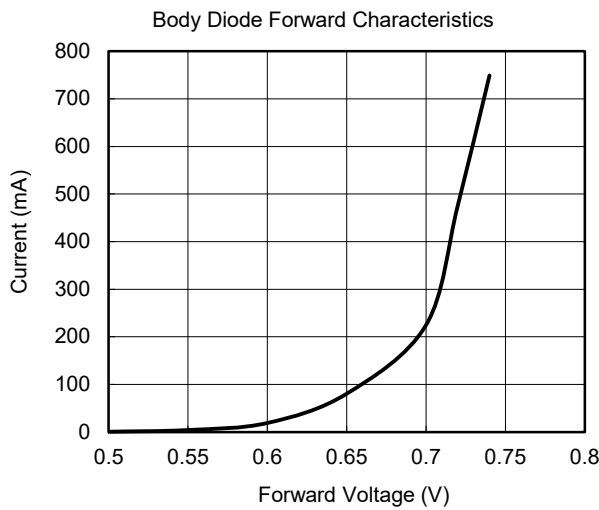
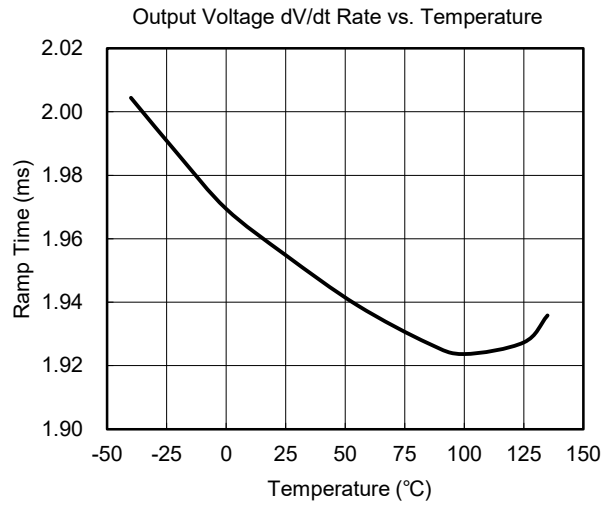
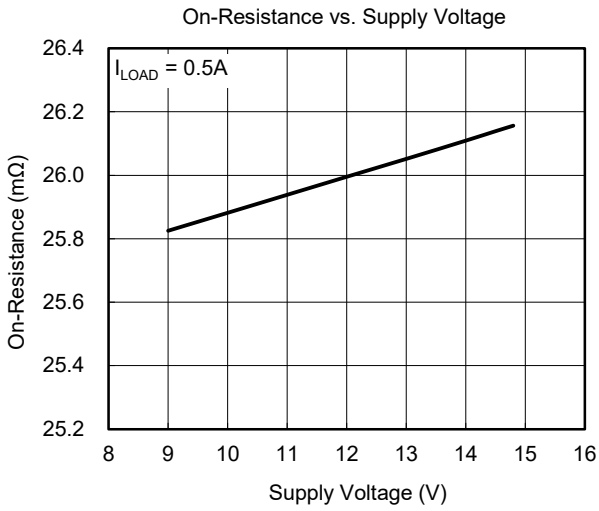

TYPICAL APPLICATION CIRCUITS

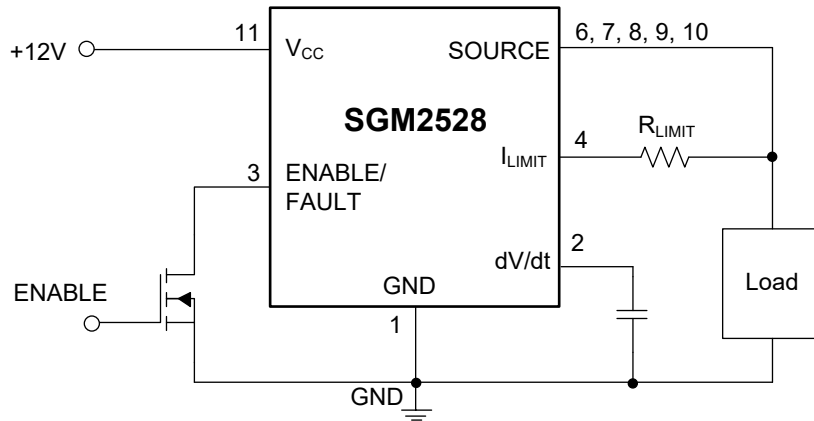

Figure 1. Application Circuit with Direct Current Sensing

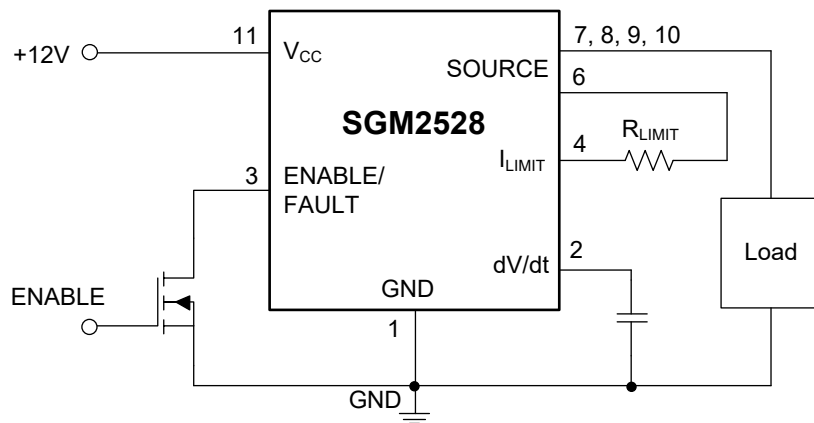

Figure 2. Application Circuit with Kelvin Current Sensing

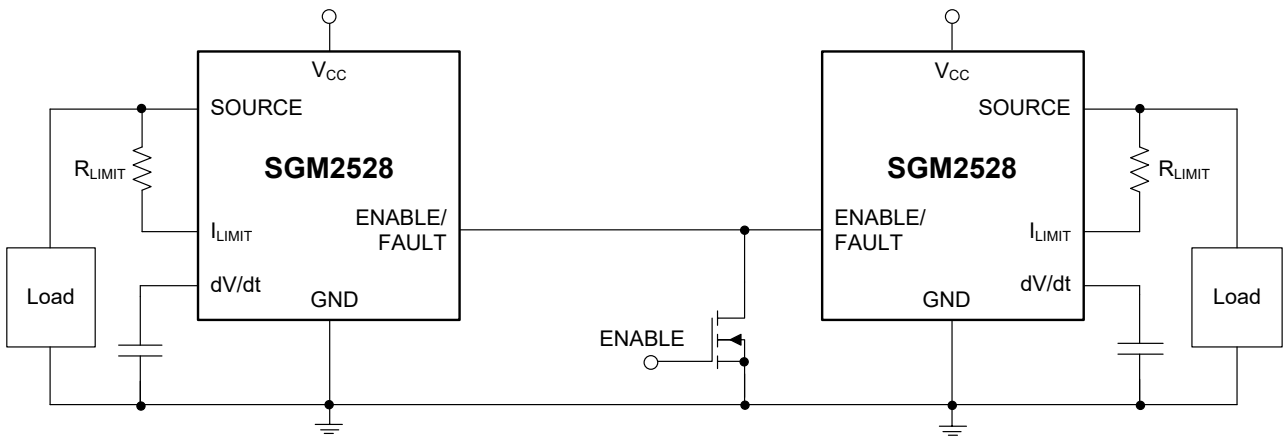
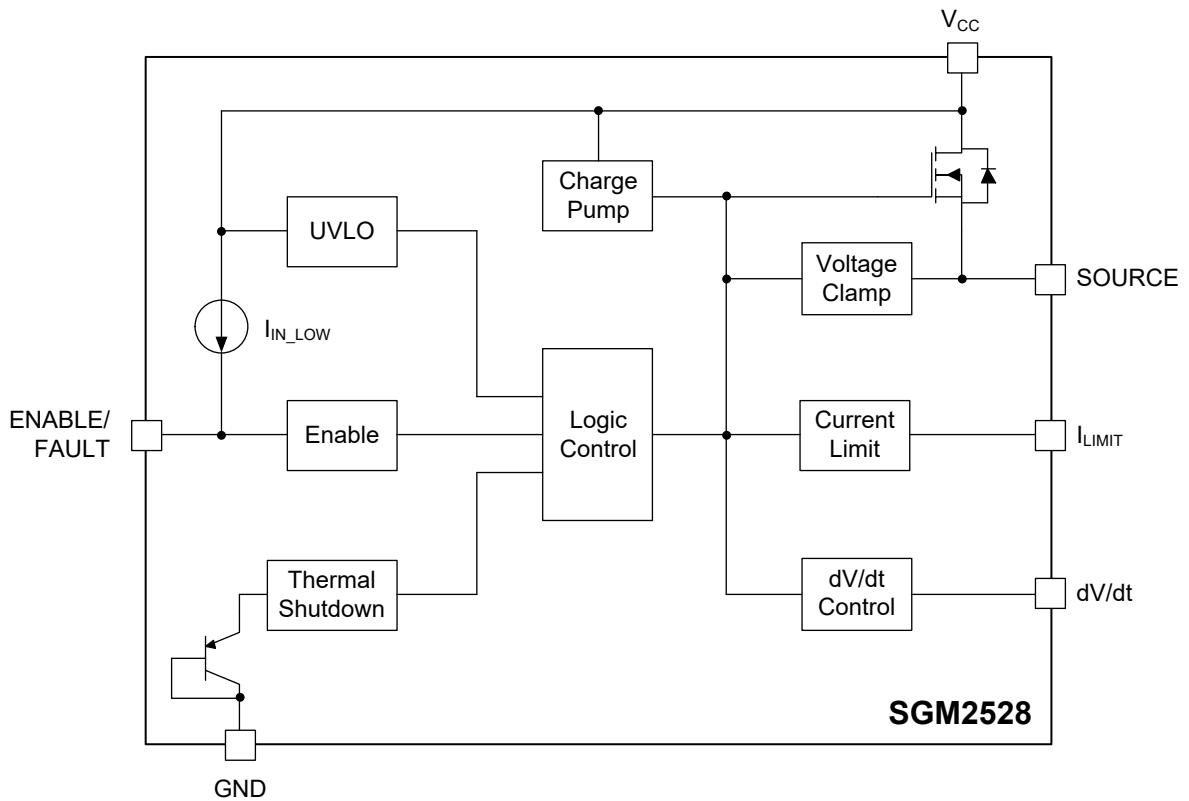

Figure 3. Common Thermal Shutdown

FUNCTIONAL BLOCK DIAGRAM



NOTE: 1. SGM2528A and SGM2528B versions.

Figure 4. Block Diagram

REVISION HISTORY

NOTE: Page numbers for previous revisions may differ from page numbers in the current version.

AUGUST 2020 – REV.A to REV.A.1		Page
Updated Typical Performance Characteristics section		6
Changes from Original (JULY 2020) to REV.A		Page
Changed from product preview to production data.....		All

PACKAGE INFORMATION

PACKAGE OUTLINE DIMENSIONS

TDFN-3×3-10L

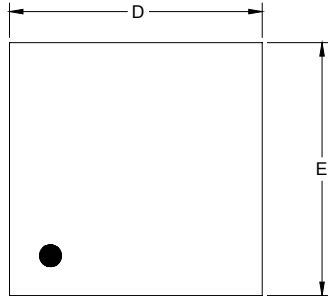

TOP VIEW

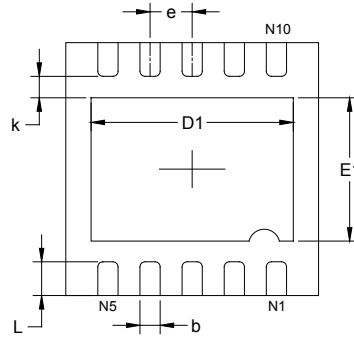

BOTTOM VIEW

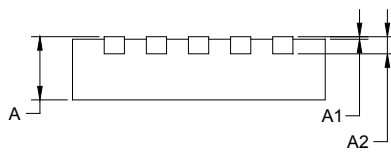

SIDE VIEW

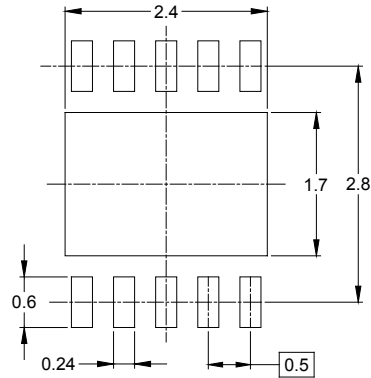

RECOMMENDED LAND PATTERN (Unit: mm)

Symbol	Dimensions In Millimeters		Dimensions In Inches	
	MIN	MAX	MIN	MAX
A	0.700	0.800	0.028	0.031
A1	0.000	0.050	0.000	0.002
A2	0.203 REF		0.008 REF	
D	2.900	3.100	0.114	0.122
D1	2.300	2.600	0.091	0.103
E	2.900	3.100	0.114	0.122
E1	1.500	1.800	0.059	0.071
k	0.200 MIN		0.008 MIN	
b	0.180	0.300	0.007	0.012
e	0.500 TYP		0.020 TYP	
L	0.300	0.500	0.012	0.020

PACKAGE INFORMATION

TAPE AND REEL INFORMATION

REEL DIMENSIONS

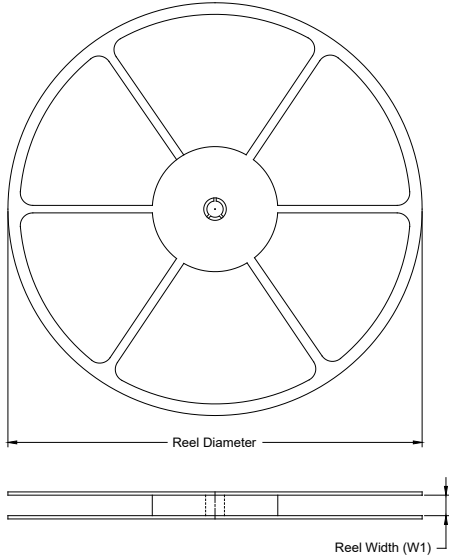

TAPE DIMENSIONS

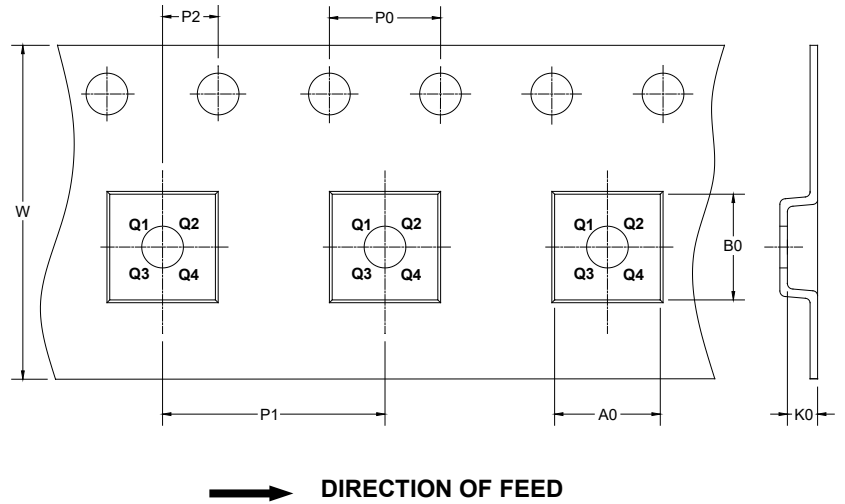

NOTE: The picture is only for reference. Please make the object as the standard.

KEY PARAMETER LIST OF TAPE AND REEL

Package Type	Reel Diameter	Reel Width W1 (mm)	A0 (mm)	B0 (mm)	K0 (mm)	P0 (mm)	P1 (mm)	P2 (mm)	W (mm)	Pin1 Quadrant
TDFN-3×3-10L	13"	12.4	3.35	3.35	1.13	4.0	8.0	2.0	12.0	Q1

020001

PACKAGE INFORMATION

CARTON BOX DIMENSIONS

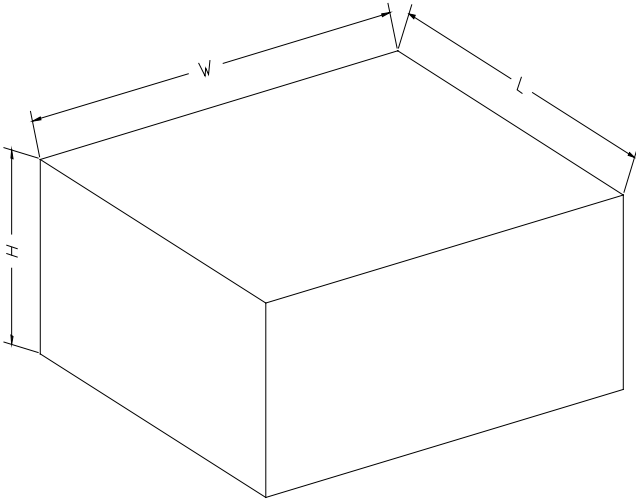

NOTE: The picture is only for reference. Please make the object as the standard.

KEY PARAMETER LIST OF CARTON BOX

Reel Type	Length (mm)	Width (mm)	Height (mm)	Pizza/Carton
13"	386	280	370	5

DD0002