

SGM3206

Unregulated 60mA Charge Pump Voltage Inverter

GENERAL DESCRIPTION

The SGM3206 generates an unregulated negative output voltage from an input voltage ranging from 1.4V to 5.5V. The device is typically supplied by a pre-regulated supply rail of 5V or 3.3V. Due to its wide input voltage range, two or three NiCd, NiMH, or alkaline battery cells, as well as one Li-ion cell can also power them.

Only three external capacitors are required to build a complete DC/DC charge pump inverter. Assembled in a small package, the complete converter can be built on a 50mm² board area. Additional board area and component count reduction is achieved by replacing the Schottky diode that is typically needed for start-up into load by integrated circuitry.

The SGM3206 can deliver a maximum output current of 60mA with a typical conversion efficiency of greater than 85% over a wide output current range. The fixed switching frequency is 47kHz.

The SGM3206 is available in SOT-23-5 package. It operates over an ambient temperature range of -40°C to +85°C.

TYPICAL APPLICATION

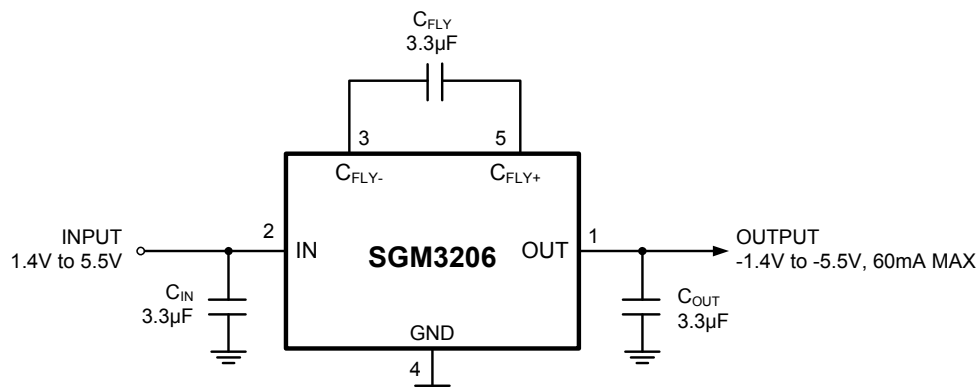

FEATURES

- Inverts Input Supply Voltage
- Up to 60mA Output Current
- Input Voltage Range from 1.4V to 5.5V
- Quiescent Current: 115µA (TYP)
- Integrated Active Schottky Diode for Start-Up into Load
- -40°C to +85°C Operating Temperature Range
- Available in Green SOT-23-5 Package

APPLICATIONS

LCD Bias
GaAs Bias for RF Power Amps
Sensor Supply in Portable Instruments
Bipolar Amplifier Supply

SGM3206

Unregulated 60mA Charge Pump Voltage Inverter

PACKAGE/ORDERING INFORMATION

MODEL	PIN-PACKAGE	SPECIFIED TEMPERATURE RANGE	ORDERING NUMBER	PACKAGE MARKING	PACKAGE OPTION
SGM3206	SOT-23-5	-40°C to +85°C	SGM3206YN5G/TR	SL7XX	Tape and Reel, 3000

NOTE: XX = Date Code.

MARKING INFORMATION

SL7 X X

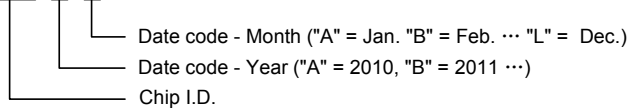

For example: SL7CA (2012, January)

ABSOLUTE MAXIMUM RATINGS

Voltage Range	
IN to GND.....	-0.3V to 6V
OUT to GND.....	-6V to 0.3V
C _{FLY-} to GND.....	0.3V to V _{OUT} - 0.3V
C _{FLY+} to GND.....	-0.3V to V _{IN} + 0.3V
Continuous Output Current.....	100mA
Operating Temperature Range.....	-40°C to +85°C
Junction Temperature.....	150°C
Storage Temperature Range.....	-65°C to +150°C
Lead Temperature (Soldering, 10s)	260°C
ESD Susceptibility	
HBM.....	8000V
MM.....	400V

NOTE:

Stresses beyond those listed under "Absolute Maximum Ratings" may cause permanent damage to the device. These are stress ratings only, and functional operation of the device at these or any other conditions beyond those indicated in the operational sections of the specifications is not implied. Exposure to absolute maximum rating conditions for extended periods may affect device reliability.

CAUTION

This integrated circuit can be damaged by ESD if you don't pay attention to ESD protection. SGMICRO recommends that all integrated circuits be handled with appropriate precautions. Failure to observe proper handling and installation procedures can cause damage. ESD damage can range from subtle performance degradation to complete device failure. Precision integrated circuits may be more susceptible to damage because very small parametric changes could cause the device not to meet its published specifications.

SGMICRO reserves the right to make any change in circuit design, specification or other related things if necessary without notice at any time. Please contact SGMICRO sales office to get the latest datasheet.

SGM3206

**Unregulated 60mA
Charge Pump Voltage Inverter**

PIN CONFIGURATION (TOP VIEW)

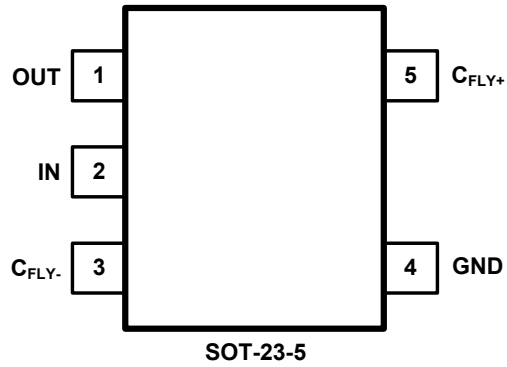

PIN DESCRIPTION

NAME	PIN	FUNCTION
OUT	1	Power Output with $V_{OUT} = -V_{IN}$. Bypass OUT to GND with the output filter capacitor C_{OUT} .
IN	2	Supply Input. Connect to an input supply in the 1.4V to 5.5V range. Bypass IN to GND with a capacitor that has the same value as the flying capacitor.
C _{FLY-}	3	Negative Terminal of the Flying Capacitor C_{FLY} .
GND	4	Ground.
C _{FLY+}	5	Positive Terminal of the Flying Capacitor C_{FLY} .

SGM3206

Unregulated 60mA Charge Pump Voltage Inverter

ELECTRICAL CHARACTERISTICS

($C_{IN} = C_{FLY} = C_{OUT} = 3.3\mu\text{F}$, $V_{IN} = 5\text{V}$, Full = -40°C to $+85^{\circ}\text{C}$. Typical values are at $T_A = +25^{\circ}\text{C}$, unless otherwise noted.)

PARAMETER	SYMBOL	CONDITIONS	TEMP	MIN	TYP	MAX	UNITS
Input Voltage Range	V_{IN}	$R_L = 5\text{k}\Omega$	Full	1.4		5.5	V
Maximum Output Current Range at OUT	I_{OUT}		Full	60			mA
Output Voltage	V_{OUT}		25°C		$-V_{IN}$		V
Output Voltage Ripple	V_{PP}	$I_{OUT} = 5\text{mA}$	25°C		30		mV _{P-P}
Quiescent Current (No Load Input Current)	I_Q		25°C		115	135	μA
			Full			166	
Internal Switching Frequency	f_{OSC}		25°C	38	47	57	kHz
			Full	35		60	
Impedance		$I_{OUT} = 30\text{mA}$	25°C		10	13	Ω
			Full			15	

TYPICAL PERFORMANCE CHARACTERISTICS

$C_{IN} = C_{FLY} = C_{OUT} = 3.3\mu F$, $T_A = 25^\circ C$, unless otherwise noted.

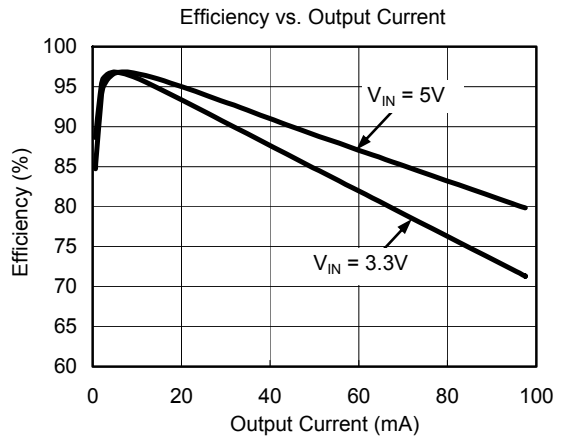
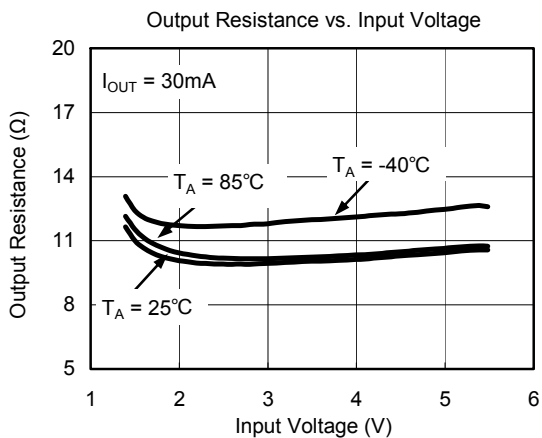
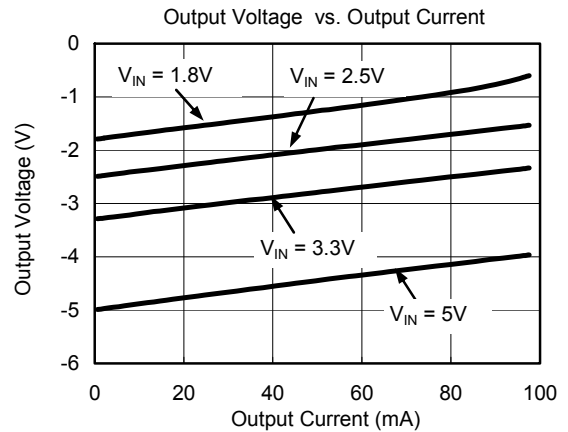
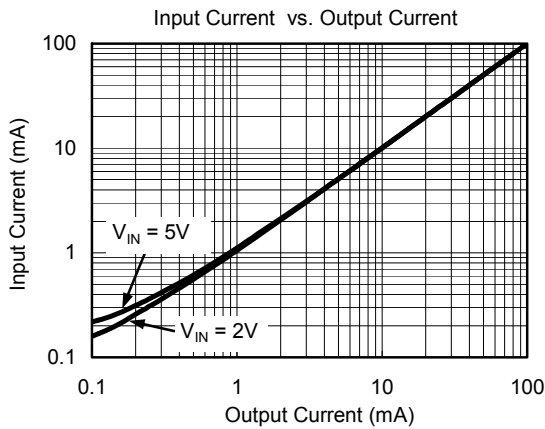
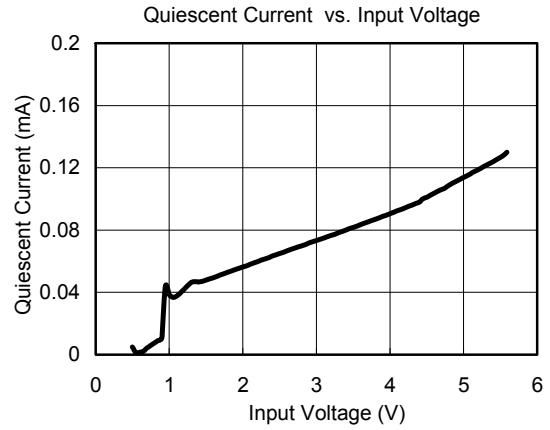
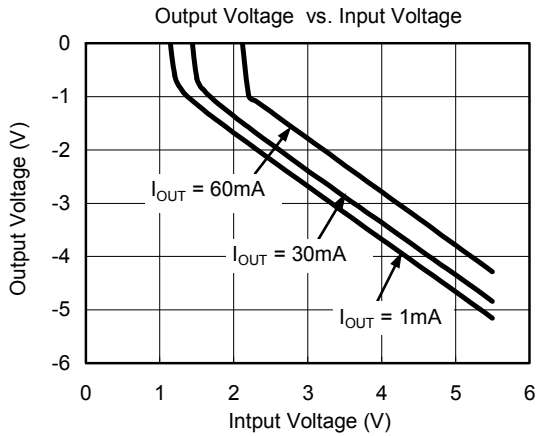

TYPICAL PERFORMANCE CHARACTERISTICS

T_A = 25°C, unless otherwise noted.

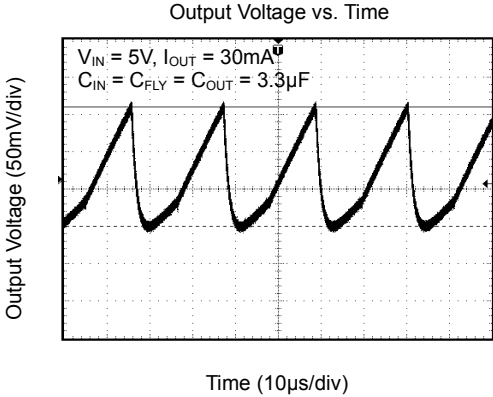

DETAILED DESCRIPTION

Operating Principle

The SGM3206 charge pump inverts the voltage applied to the input. For the best performance, use low equivalent series resistance (ESR) capacitors (e.g., ceramic). During the first half-cycle, switches S2 and S4 open, switches S1 and S3 close, and capacitor C_{FLY} charges to the voltage at V_{IN}. During the second half-cycle, S1 and S3 open and S2 and S4 close. This connects the positive terminal of C_{FLY} to GND and the negative to V_{OUT}. By connecting C_{FLY} in parallel, C_{OUT} is charged negative. The actual voltage at the output is more positive than -V_{IN}, since switches S1 - S4 have resistance and the load drains charge from C_{OUT}.

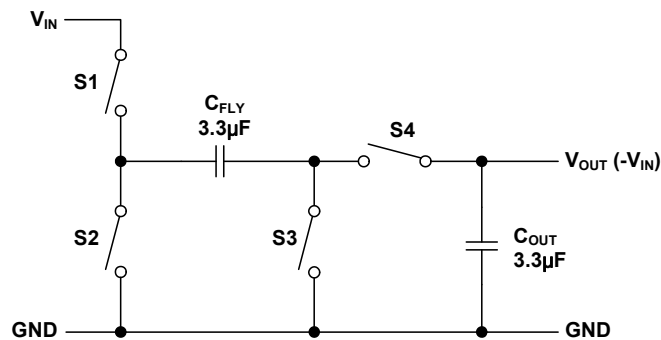

Figure 1. Operating Principle

Charge Pump Output Resistance

The SGM3206 device is not voltage regulator. The charge pump output source resistance is approximately 10Ω at room temperature (with V_{IN} = 5V), and V_{OUT} approaches 5V when lightly loaded. V_{OUT} will droop toward GND as load current increases.

$$V_{OUT} = -(V_{IN} - R_{OUT} \times I_{OUT})$$

$$R_{OUT} \approx \frac{1}{f_{OSC} \times C_{FLY}} + 4(2R_{SWITCH} + ESR_{C_{FLY}}) + ESR_{C_{OUT}}$$

Where:

R_{OUT} = output resistance of the converter

R_{SWITCH} = resistance of a single MOSFET-switch inside the converter

f_{OSC} = oscillator frequency

Efficiency Considerations

The power efficiency of a switched-capacitor voltage converter is affected by three factors: the internal losses in the converter IC, the resistive losses of the capacitors, and the conversion losses during charge transfer between the capacitors. The internal losses are associated with the IC's internal functions, such as driving the switches, oscillator, etc. These losses are affected by operating conditions such as input voltage, temperature, and frequency. The next two losses are associated with the voltage converter circuit's output resistance. Switch losses occur because of the on-resistance of the MOSFET switches in the IC. Charge pump capacitor losses occur because of their ESR. The relationship between these losses and the output resistance is as follows:

$$P_{CAPACITOR\ LOSSES} + P_{CONVERSION\ LOSSES} = I_{OUT}^2 \times R_{OUT}$$

The first term is the effective resistance from an ideal switched-capacitor circuit. Conversion losses occur during the charge transfer between C_{FLY} and C_{OUT} when there is a voltage difference between them. The power loss is:

$$P_{CONVERSION\ LOSS} = \left[\frac{1}{2} \times C_{FLY} (V_{IN}^2 - V_{OUT}^2) + \frac{1}{2} C_{OUT} (V_{RIPPLE}^2 - 2V_{OUT} V_{RIPPLE}) \right] \times f_{OSC}$$

The efficiency of the SGM3206 is dominated by their quiescent supply current at low output current and by their output impedance at higher current.

$$\eta \cong \frac{I_{OUT}}{I_{OUT} + I_Q} \left(1 - \frac{I_{OUT} \times R_{OUT}}{V_{IN}} \right)$$

where, I_Q = quiescent current.

DETAILED DESCRIPTION

Capacitor Selection

To maintain the lowest output resistance, use capacitors with low ESR (see Table 1). The charge pump output resistance is a function of C_{FLY} 's and C_{OUT} 's ESR. Therefore, minimizing the charge pump capacitor's ESR minimizes the total output resistance. The capacitor values are closely linked to the required output current and the output noise and ripple requirements. It is possible to only use 3.3 μ F capacitors of the same type.

Table 1. Recommended Capacitor Values

V_{IN} (V)	I_{OUT} (mA)	C_{IN} (μ F)	C_{FLY} (μ F)	C_{OUT} (μ F)
1.4 to 5.5	60	3.3	3.3	3.3

Input Capacitor (C_{IN})

Bypass the incoming supply to reduce its AC impedance and the impact of the SGM3206 switching noise. The recommended bypassing depends on the circuit configuration and where the load is connected. When the inverter is loaded from OUT to GND, current from the supply switches between $2 \times I_{OUT}$ and zero. Therefore, use a large bypass capacitor (e.g., equal to the value of C_{FLY}) if the supply has high AC impedance. When the inverter is loaded from IN to OUT, the circuit draws $2 \times I_{OUT}$ constantly, except for short switching spikes. A 0.1 μ F bypass capacitor is sufficient.

Flying Capacitor (C_{FLY})

Increasing the flying capacitor's size reduces the output resistance. Small values increase the output resistance. Above a certain point, increasing C_{FLY} 's capacitance has a negligible effect, because the output resistance becomes dominated by the internal switch resistance and capacitor ESR.

Output Capacitor (C_{OUT})

Increasing the output capacitor's size reduces the output ripple voltage. Decreasing its ESR reduces both output resistance and ripple. Smaller capacitance values can be used with light loads if higher output ripple can be tolerated. Use the following equation to calculate the peak-to-peak ripple.

$$V_{OUT\ RIPPLE} = \frac{I_{OUT}}{f_{OSC} \times C_{OUT}} + 2 \times I_{OUT} \times ESR_{C_{OUT}}$$

APPLICATION INFORMATION**Voltage Inverter**

The most common application for this device is a charge pump voltage inverter (see Figure 2). This application requires only two external components: capacitors C_{FLY} and C_{OUT} , plus a bypass capacitor, if necessary.

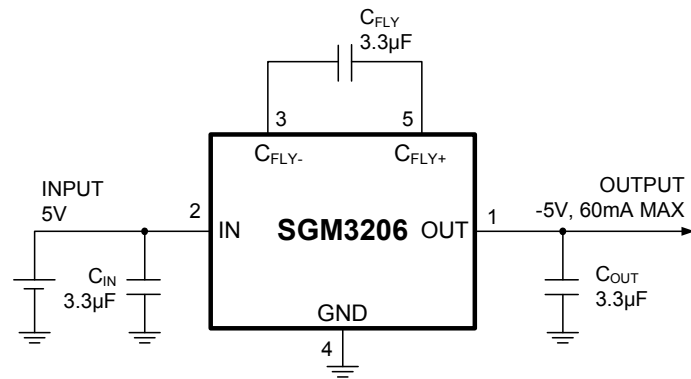
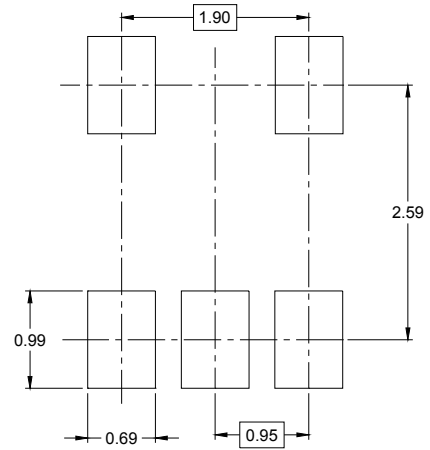
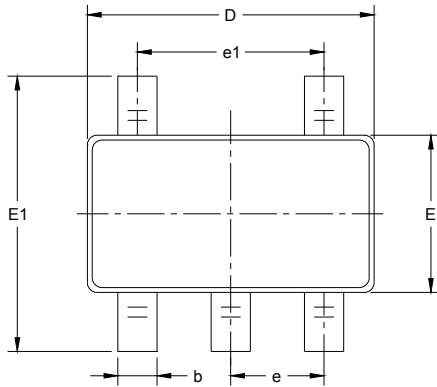

Figure 2. Typical Operating Circuit

For the maximum output current and best performance, three ceramic capacitors of $3.3\mu\text{F}$ are recommended. For lower currents or higher allowed output voltage ripple, other capacitors can also be used. It is recommended that the output capacitor has a minimum value of $3.3\mu\text{F}$. With flying capacitors lower than $3.3\mu\text{F}$, the maximum output power will decrease.

PACKAGE OUTLINE DIMENSIONS

SOT-23-5



RECOMMENDED LAND PATTERN (Unit: mm)

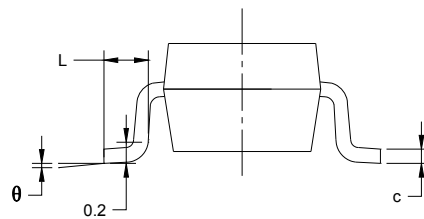
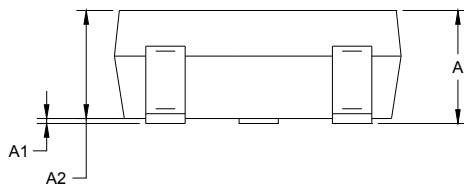

Symbol	Dimensions In Millimeters		Dimensions In Inches	
	MIN	MAX	MIN	MAX
A	1.050	1.250	0.041	0.049
A1	0.000	0.100	0.000	0.004
A2	1.050	1.150	0.041	0.045
b	0.300	0.500	0.012	0.020
c	0.100	0.200	0.004	0.008
D	2.820	3.020	0.111	0.119
E	1.500	1.700	0.059	0.067
E1	2.650	2.950	0.104	0.116
e	0.950 BSC		0.037 BSC	
e1	1.900 BSC		0.075 BSC	
L	0.300	0.600	0.012	0.024
theta	0°	8°	0°	8°

TAPE AND REEL INFORMATION

REEL DIMENSIONS

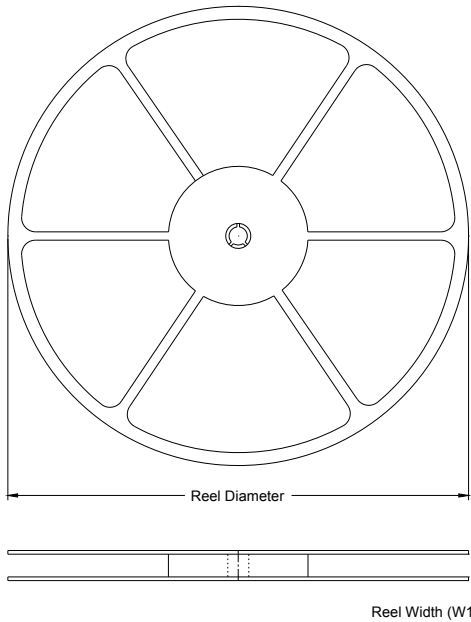

TAPE DIMENSIONS

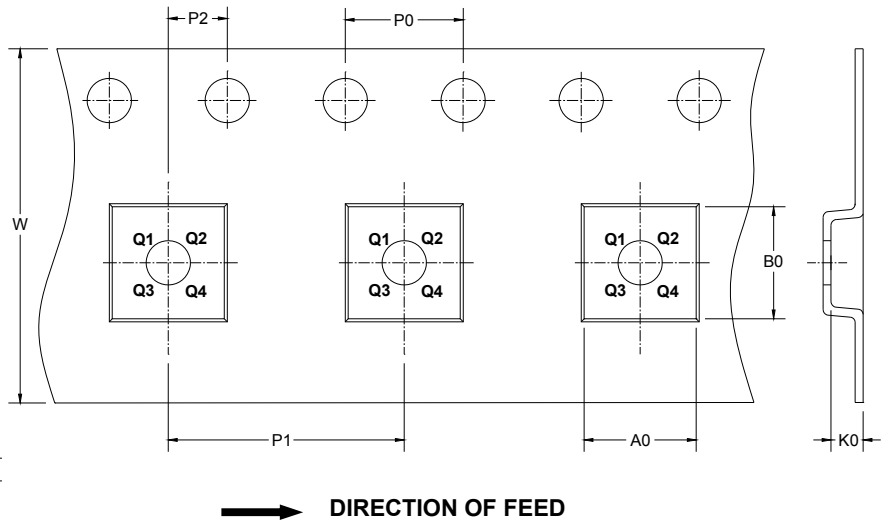

NOTE: The picture is only for reference. Please make the object as the standard.

KEY PARAMETER LIST OF TAPE AND REEL

Package Type	Reel Diameter	Reel Width W1 (mm)	A0 (mm)	B0 (mm)	K0 (mm)	P0 (mm)	P1 (mm)	P2 (mm)	W (mm)	Pin1 Quadrant
SOT-23-5	7"	9.5	3.2	3.2	1.4	4.0	4.0	2.0	8.0	Q3

SGM3206

Unregulated 60mA Charge Pump Voltage Inverter

CARTON BOX DIMENSIONS

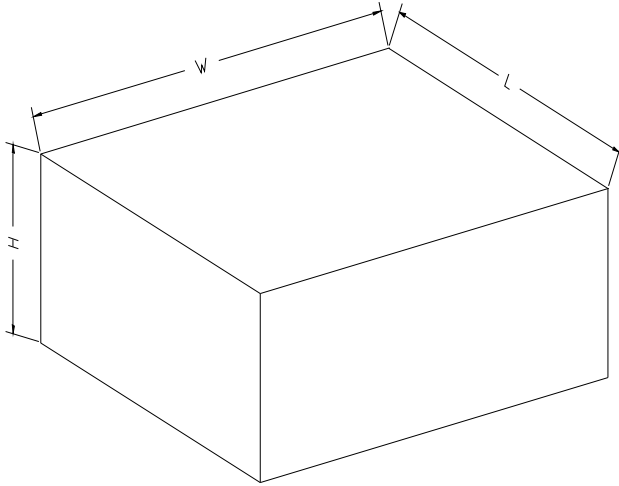

NOTE: The picture is only for reference. Please make the object as the standard.

KEY PARAMETER LIST OF CARTON BOX

Reel Type	Length (mm)	Width (mm)	Height (mm)	Pizza/Carton
7" (Option)	368	227	224	8
7"	442	410	224	18