

# SGM8604-2XTDU8G

## 15MHz, High Output Drive, High Precision, Low Noise Operational Amplifier

### GENERAL DESCRIPTION

The SGM8604-2XTDU8G is a dual, low noise, high precision CMOS operational amplifier that provides a high output current of 235mA, rail-to-rail output operation from a range of 2.7V to 5.5V single supply.

The SGM8604-2XTDU8G offers low input offset voltage, low input offset voltage drift and high output current drive. The device also can achieve a high 15MHz gain-bandwidth product and a high 7V/ $\mu$ s slew rate.

The SGM8604-2XTDU8G is specifically designed to drive high current load, such as 32 $\Omega$  headset,  $V_{BIAS}$  of RF power amplifier, etc.

The SGM8604-2XTDU8G is available in a Green TDFN-3 $\times$ 3-8AL package. It operates over an ambient temperature range of -40 $^{\circ}$ C to +125 $^{\circ}$ C.

### FEATURES

- **Output Drive Capability: 235mA**
- **Low Input Offset Voltage: 10 $\mu$ V (MAX)**
- **Low Input Offset Voltage Drift: 20nV/ $^{\circ}$ C (TYP)**
- **Low Noise: 28nV/ $\sqrt{\text{Hz}}$  at 1kHz**
- **Gain-Bandwidth Product: 15MHz**
- **High Slew Rate: 7V/ $\mu$ s**
- **High Open-Loop Gain ( $R_L = 2\text{k}\Omega$ ): 145dB**
- **Power Supply Rejection Ratio: 120dB**
- **Over-Temperature Protection**
- **No Phase Reversal for Overdriven Inputs**
- **Rail-to-Rail Input and Output**
- **Supply Voltage Range: 2.7V to 5.5V**
- **Quiescent Current: 2.3mA (TYP)**
- **-40 $^{\circ}$ C to +125 $^{\circ}$ C Operating Temperature Range**
- **Available in a Green TDFN-3 $\times$ 3-8AL Package**

### APPLICATIONS

$V_{BIAS}$  of RF Power Amplifiers  
Portable Stereo Headphone Drivers (32 $\Omega$ )  
Battery-Powered Equipment  
Audio System  
Optical Module  
DAC Buffer  
Industrial Equipment

### TYPICAL APPLICATION

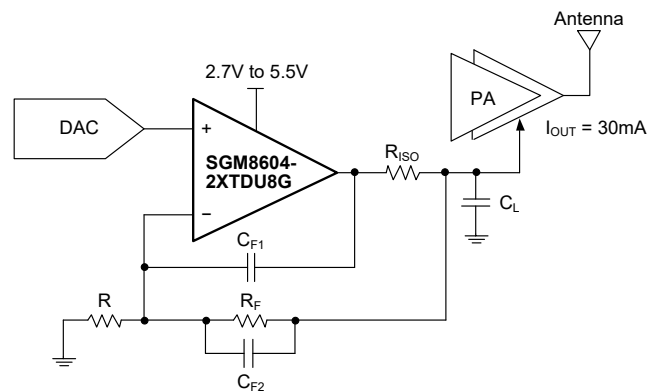

# SGM8604-2XTDU8G

# 15MHz, High Output Drive, High Precision, Low Noise Operational Amplifier

## PACKAGE/ORDERING INFORMATION

MODEL	PACKAGE DESCRIPTION	SPECIFIED TEMPERATURE RANGE	ORDERING NUMBER	PACKAGE MARKING	PACKING OPTION
SGM8604-2XTDU8G	TDFN-3x3-8AL	-40°C to +125°C	SGM8604-2XTDU8G/TR	SGM RC7DU XXXXX	Tape and Reel, 4000

## MARKING INFORMATION

NOTE: XXXXX = Date Code, Trace Code and Vendor Code.

**XXXXX**

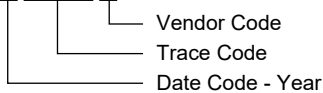

Green (RoHS & HSF): SG Micro Corp defines "Green" to mean Pb-Free (RoHS compatible) and free of halogen substances. If you have additional comments or questions, please contact your SGMICRO representative directly.

## ABSOLUTE MAXIMUM RATINGS

Supply Voltage, +V <sub>s</sub> to -V <sub>s</sub> .....	6V
All Other Pins.....	(-V <sub>s</sub> ) - 0.3V to (+V <sub>s</sub> ) + 0.3V
Junction Temperature.....	+150°C
Storage Temperature Range .....	-65°C to +150°C
Lead Temperature (Soldering, 10s).....	+260°C
ESD Susceptibility	
HBM.....	7000V
CDM .....	1000V

## RECOMMENDED OPERATING CONDITIONS

Operating Temperature Range .....	-40°C to +125°C
Operating Supply Voltage Range .....	2.7V to 5.5V

## OVERSTRESS CAUTION

Stresses beyond those listed in Absolute Maximum Ratings may cause permanent damage to the device. Exposure to absolute maximum rating conditions for extended periods may affect reliability. Functional operation of the device at any conditions beyond those indicated in the Recommended Operating Conditions section is not implied.

## ESD SENSITIVITY CAUTION

This integrated circuit can be damaged if ESD protections are not considered carefully. SGMICRO recommends that all integrated circuits be handled with appropriate precautions. Failure to observe proper handling and installation procedures can cause damage. ESD damage can range from subtle

performance degradation to complete device failure. Precision integrated circuits may be more susceptible to damage because even small parametric changes could cause the device not to meet the published specifications.

## DISCLAIMER

SG Micro Corp reserves the right to make any change in circuit design, or specifications without prior notice.

## PIN CONFIGURATION

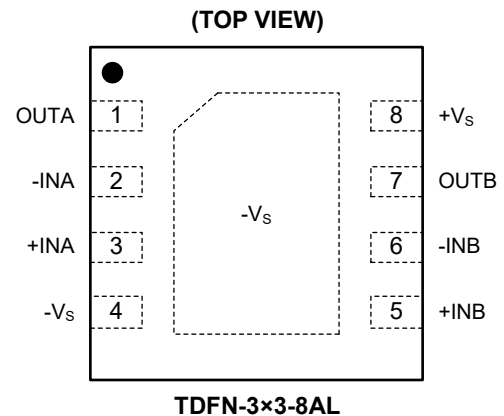

NOTE: The exposed pad must be connected to -V<sub>s</sub> or left floating. Connect it to -V<sub>s</sub> plane can maximize thermal performance.

# 15MHz, High Output Drive, High Precision, Low Noise Operational Amplifier

## SGM8604-2XTDU8G

### ELECTRICAL CHARACTERISTICS

( $V_S = 2.7V$  to  $5V$ ,  $-V_S = 0V$ ,  $V_{CM} = V_S/2$ ,  $V_{OUT} = V_S/2$ ,  $R_L$  connected to  $V_S/2$ , Full =  $-40^\circ C$  to  $+125^\circ C$ , typical values are at  $T_A = +25^\circ C$ , unless otherwise noted.)

PARAMETER	CONDITIONS	TEMP	MIN	TYP	MAX	UNITS	
<b>Input Characteristics</b>							
Input Offset Voltage ( $V_{OS}$ )	$V_S = 2.7V$	+25°C		2	8	μV	
	$V_S = 5V$	+25°C		3	10		
Input Offset Voltage Drift ( $\Delta V_{OS}/\Delta T$ )	$V_S = 2.7V$	+25°C		24	126	nV/°C	
	$V_S = 5V$	+25°C		20	130		
Input Bias Current ( $I_B$ )	$V_S = 5V$	+25°C		300	520	pA	
Input Offset Current ( $I_{OS}$ )	$V_S = 5V$	+25°C		500	1000	pA	
Common Mode Voltage Range ( $V_{CM}$ )		Full	$(-V_S) - 0.1$		$(+V_S) + 0.1$	V	
Common Mode Rejection Ratio (CMRR)	$(-V_S) - 0.1V < V_{CM} < (+V_S) + 0.1V$	+25°C	104	116		dB	
		Full	90				
Open-Loop Voltage Gain ( $A_{OL}$ )	$V_S = 2.7V$ , $(-V_S) + 0.2V < V_{OUT} < (+V_S) - 0.2V$	$R_L = 2k\Omega$	+25°C	112	140	dB	
			Full	110			
		$R_L = 200\Omega$	+25°C	109	135		
			Full	106			
	$V_S = 5V$ , $(-V_S) + 0.2V < V_{OUT} < (+V_S) - 0.2V$	$R_L = 2k\Omega$	+25°C	115	145		
			Full	112			
		$R_L = 200\Omega$	+25°C	110	140		
			Full	108			
<b>Output Characteristics</b>							
Output Voltage Swing from Rail	$V_S = 2.7V$	$R_L = 32\Omega$	+25°C		245	300	mV
			Full			370	
		$R_L = 200\Omega$	+25°C		45	68	
			Full			73	
		$R_L = 2k\Omega$	+25°C		4	12	
			Full			14	
		$I_{OUT} = 10mA$	+25°C		62	100	
			Full			122	
	$V_S = 5V$	$R_L = 32\Omega$	+25°C		360	485	
			Full			585	
		$R_L = 200\Omega$	+25°C		65	95	
			Full			113	
		$R_L = 2k\Omega$	+25°C		7	15	
			Full			18	
		$I_{OUT} = 10mA$	+25°C		54	85	
			Full			102	
Output Short-Circuit Current ( $I_{SC}$ )	$V_S = 2.7V$	+25°C	85	120		mA	
		Full	58				
	$V_S = 5V$	+25°C	185	235			
		Full	154				

# 15MHz, High Output Drive, High Precision, Low Noise Operational Amplifier

## SGM8604-2XTDU8G

### ELECTRICAL CHARACTERISTICS (continued)

( $V_S = 2.7V$  to  $5V$ ,  $-V_S = 0V$ ,  $V_{CM} = V_S/2$ ,  $V_{OUT} = V_S/2$ ,  $R_L$  connected to  $V_S/2$ , Full =  $-40^\circ C$  to  $+125^\circ C$ , typical values are at  $T_A = +25^\circ C$ , unless otherwise noted.)

PARAMETER	CONDITIONS	TEMP	MIN	TYP	MAX	UNITS
<b>Power Supply</b>						
Specified Voltage Range ( $V_S$ )		Full	2.7		5.5	V
Power Supply Rejection Ratio (PSRR)	$V_S = 2.7V$ to $5.5V$	+25°C	102	120		dB
		Full	94			
Quiescent Current ( $I_Q$ )	$I_{OUT} = 0A$	+25°C		2.3	3	mA
		Full			3.64	
<b>Frequency Response</b>						
Gain-Bandwidth Product	$R_L = 10k\Omega$ , $C_L = 100pF$	+25°C		15		MHz
Slew Rate	$G = +1$ , $V_{OUT} = 2V_{P-P}$	+25°C		7		V/ $\mu s$
Total Harmonic Distortion + Noise	$V_S = 5V$ , $R_L = 32\Omega$ , $f = 10kHz$ , $BW = 10Hz$ to $90kHz$ , $V_{OUT} = 2V_{P-P}$ , $A_{VCL} = 1V/V$	+25°C		0.017		%
Input Capacitance		+25°C		20		pF
Channel-to-Channel Isolation	$f = 1kHz$ , $R_L = 100k\Omega$	+25°C		125		dB
Capacitive-Load Stability	$A_{VCL} = 1V/V$ , no sustained oscillations	+25°C		780		pF
Power-Up Time	$V_S = 5V$	+25°C		50		$\mu s$
<b>Noise</b>						
Input Voltage Noise	$f = 0.1Hz$ to $10Hz$	+25°C		0.5		$\mu V_{P-P}$
Input Voltage Noise Density	$f = 1kHz$	+25°C		28		$nV/\sqrt{Hz}$
	$f = 10kHz$	+25°C		25		

# SGM8604-2XTDU8G

# 15MHz, High Output Drive, High Precision, Low Noise Operational Amplifier

## TYPICAL PERFORMANCE CHARACTERISTICS

At  $T_A = +25^\circ\text{C}$ ,  $V_S = 5\text{V}$ , unless otherwise noted.

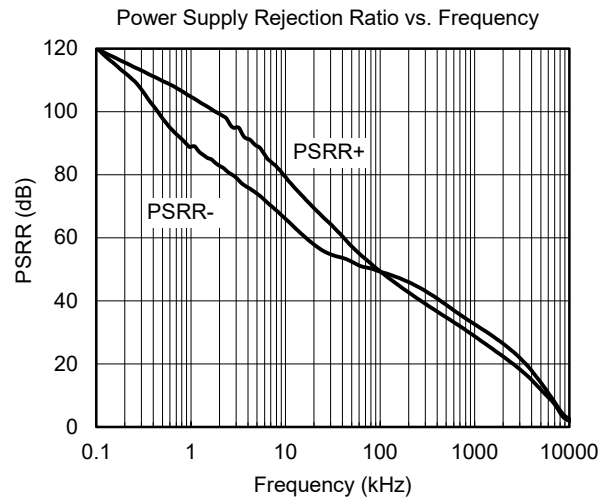
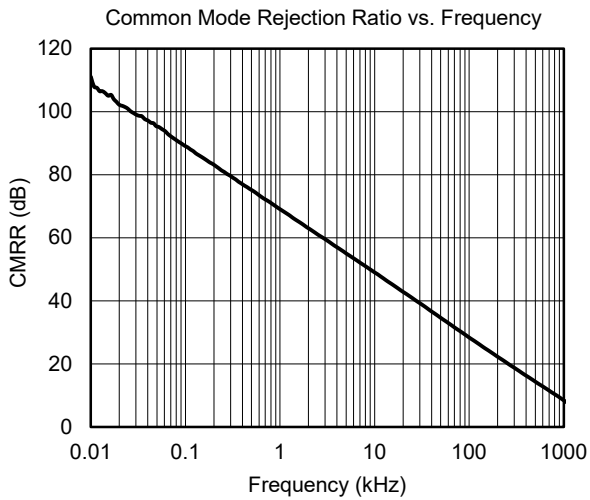
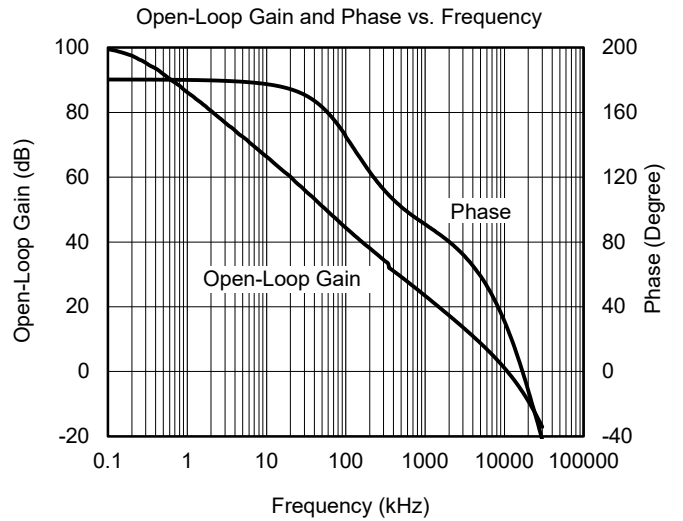
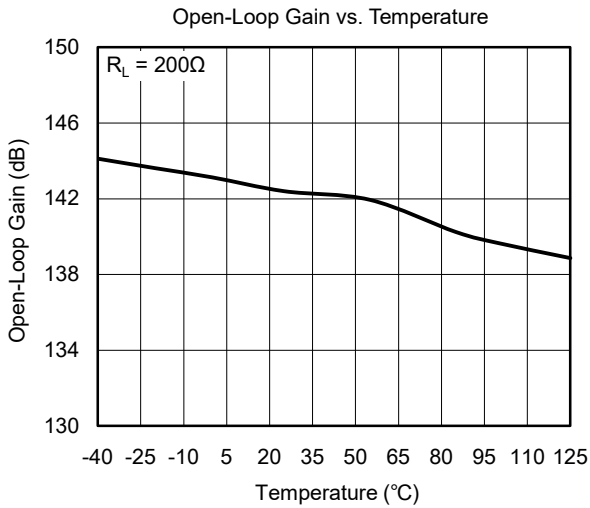
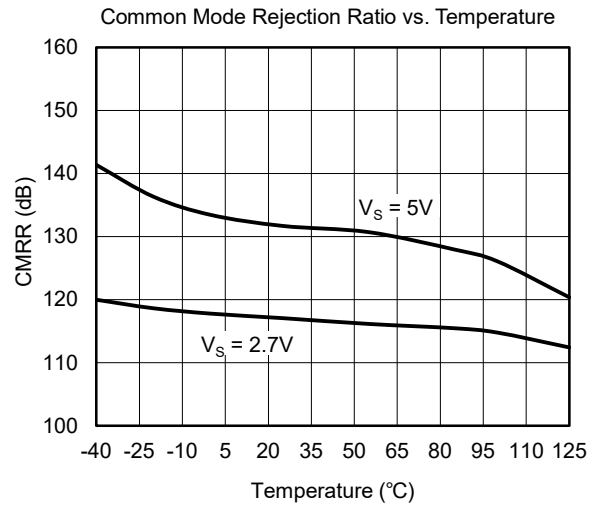
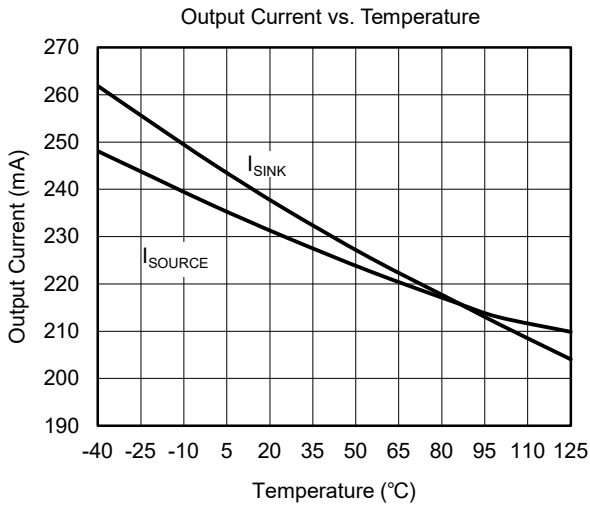

# SGM8604-2XTDU8G

# 15MHz, High Output Drive, High Precision, Low Noise Operational Amplifier

## TYPICAL PERFORMANCE CHARACTERISTICS (continued)

At  $T_A = +25^\circ\text{C}$ ,  $V_S = 5\text{V}$ , unless otherwise noted.

Large-Signal Step Response

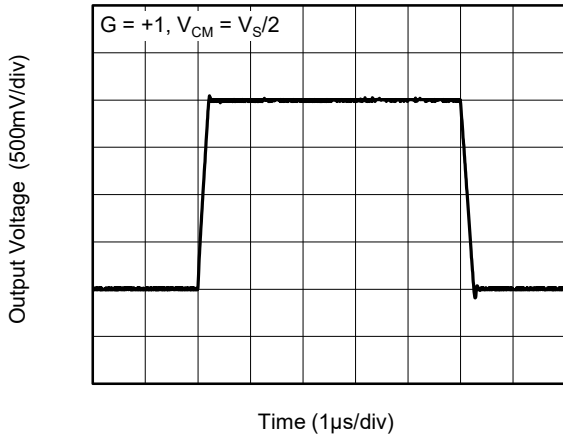

Small-Signal Step Response

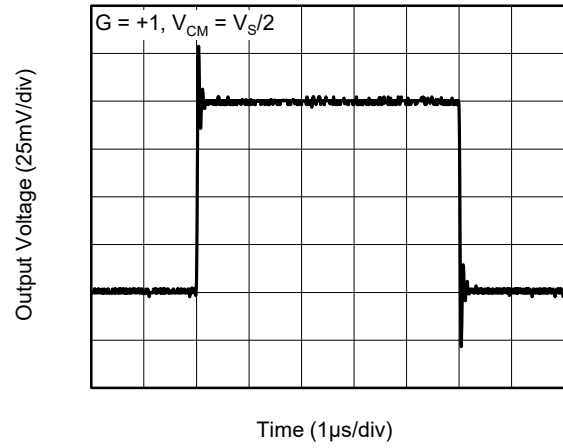

THD+N vs. Output Voltage

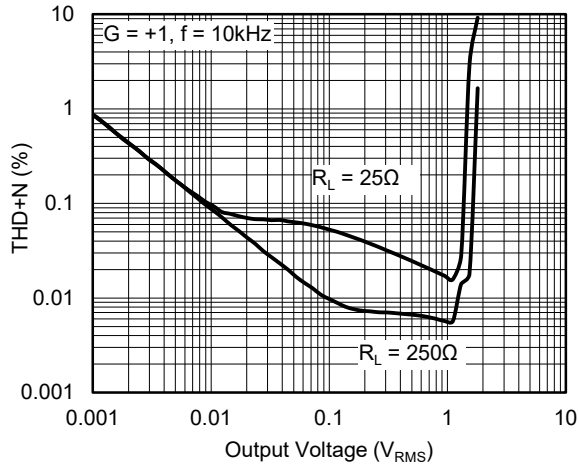

THD+N vs. Output Voltage

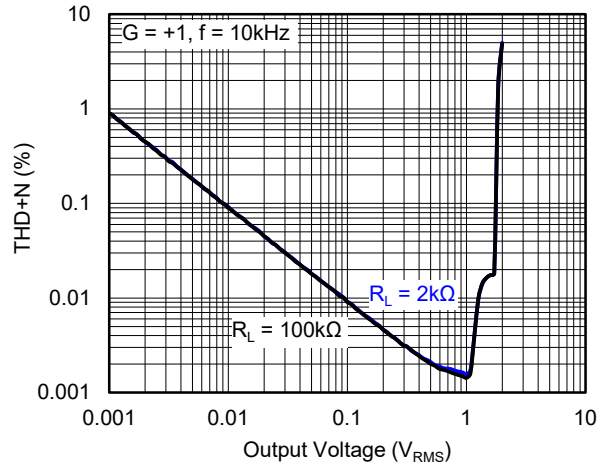

0.1Hz to 10Hz Noise

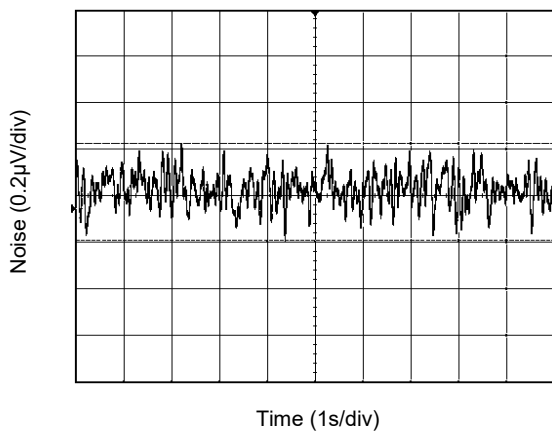

Input Voltage Noise Density vs. Frequency

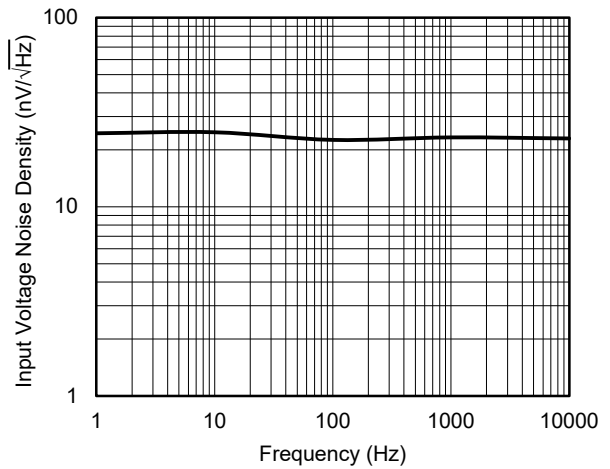

**TYPICAL PERFORMANCE CHARACTERISTICS (continued)**

At  $T_A = +25^\circ\text{C}$ ,  $V_S = 5\text{V}$ , unless otherwise noted.

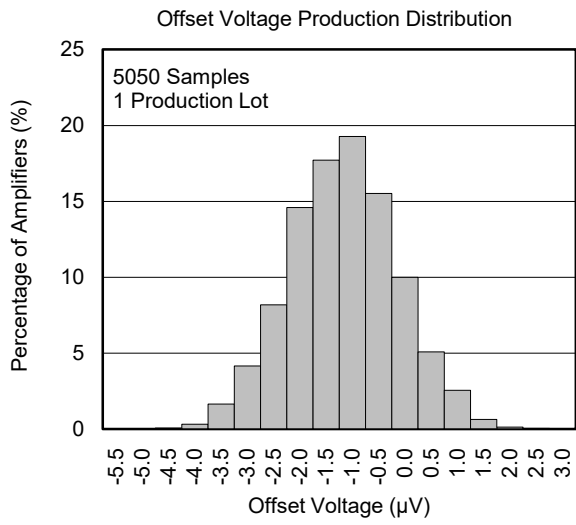

**APPLICATION INFORMATION**

**Single-Supply Stereo Headphone Driver**

A single-supply stereo headphone driver is shown in Figure 1 as an example to explain the simplified design procedure.

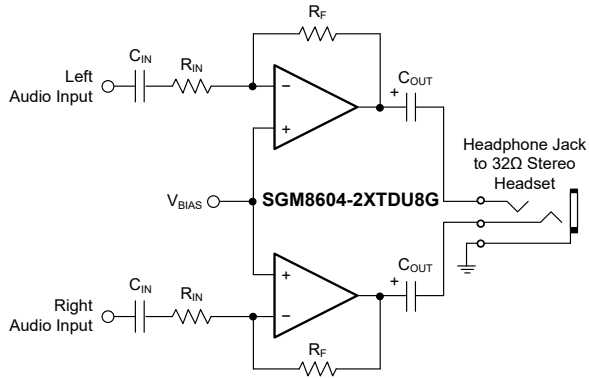

**Figure 1. Stereo Headphone Driver**

In this circuit,  $C_{IN}$  and  $R_{IN}$  form a high-pass filter, the DC bias is removed from the incoming signal. The -3dB point of the high-pass filter is using Equation 1:

$$f_{-3dB} = \frac{1}{2\pi R_{IN} C_{IN}} \quad (1)$$

The gain of driver is  $-R_F/R_{IN}$ . The  $C_{OUT}$  and the load impedance form a high-pass filter with the -3dB point determined by Equation 2:

$$f_{-3dB} = \frac{1}{2\pi R_L C_{OUT}} \quad (2)$$

**Bridge Amplifier**

A bridge amplifier circuit which can provide 200mW at 3V is shown in Figure 2. Due to differential output, this structure eliminates the large coupling capacitors in Figure 1. The voltage gain is 10V/V and the gain can be changed by changing  $R_2$ .

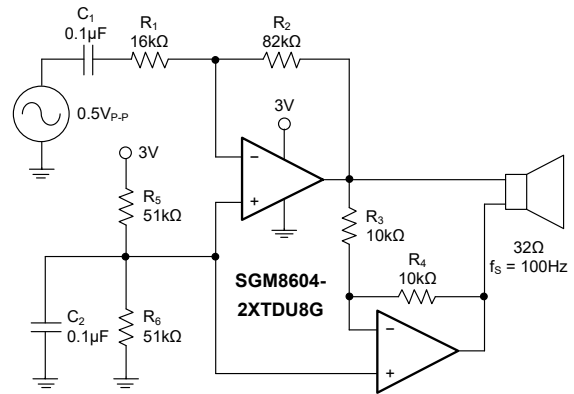

**Figure 2. 200mW Bridge Amplifier at 3V**



**APPLICATIONS INFORMATION (continued)**

**Cancel Input Capacitance**

The  $C_{IN}$  (20pF TYP) at inverting input pin will generate a pole at frequency  $(2\pi R'C_{IN})^{-1}$ , where  $R'$  is the parallel combination of the gain-setting resistor for the inverting or non-inverting amplifier in Figure 3. If the pole-frequency is less than or comparable to the unity-gain bandwidth (15MHz), the phase margin will be reduced, ringing in the step response or sustained oscillation will be generated. To cancel this pole,  $C_F$  is used to compensate  $C_{IN}$  in Figure 3. Equation 3 gives the  $C_F$  feedback capacitance.

$$C_F = 8 \times (R/R_F) \text{ pF} \quad (3)$$

where:

$R_F$  is the feedback resistor.

$R$  is the gain-setting resistor.

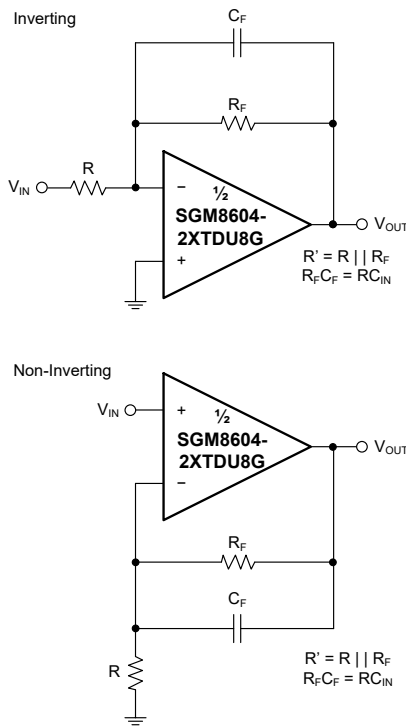

**Figure 3. Inverting and Non-Inverting Amplifiers with  $C_F$  to Compensate  $C_{IN}$**

**Input Current-Limit Protection**

For ESD diode clamping protection, when the current flowing through ESD diode exceeds the maximum rating value, the ESD diode and amplifier will be damaged, so current-limit protection will be added in some applications. One resistor is selected to limit the current not to exceed the maximum rating value. In Figure 4, a series input resistor is used to limit the input current to less than 10mA, but the drawback of this current-limit resistor is to contribute thermal noise at the amplifier input. If this resistor must be added, its value must be selected as small as possible.

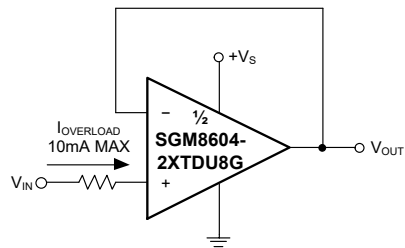

**Figure 4. Input Current-Limit Protection**

**Rail-to-Rail Output**

The SGM8604-2XTDU8G supports rail-to-rail output operation. In single power supply application, for example, when  $+V_S = 5V$ ,  $-V_S = GND$ , 2k $\Omega$  load resistor is tied from OUT pin to  $V_S/2$ , the typical output swing range is from 0.007V to 4.993V.

# 15MHz, High Output Drive, High Precision, SGM8604-2XTDU8G Low Noise Operational Amplifier

## APPLICATIONS INFORMATION (continued)

### Driving Capacitive Loads

The SGM8604-2XTDU8G is designed for unity-gain stable for capacitive load up to 780pF. In Figure 5, it shows the transient response with capacitive load ( $C_L$ ). If greater capacitive load must be driven in application, the circuit in Figure 6 can be used. In this circuit, the IR drop voltage generated by  $R_{ISO}$  is compensated by feedback loop.

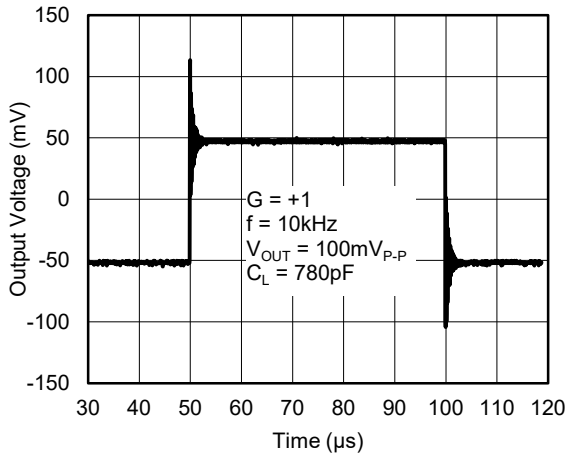

**Figure 5. Small-Signal Transient Response (Capacitive Load)**

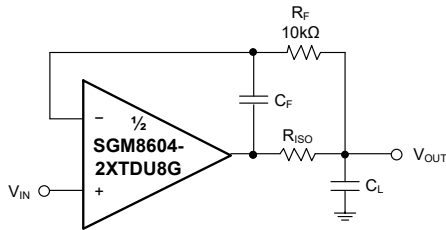

**Figure 6. Circuit to Drive Capacitive Load**

### Power Supply Decoupling and Layout

A clean and low noise power supply is very important in amplifier circuit design, besides of input signal noise, the power supply is one of important source of noise to the amplifiers through  $+V_S$  and  $-V_S$  pins. Power supply bypassing is an effective method to clear up the noise at power supply, and the low impedance path to ground of decoupling capacitor will bypass the noise to GND. In application,  $10\mu\text{F}$  ceramic capacitor paralleled with  $0.1\mu\text{F}$  or  $0.01\mu\text{F}$  ceramic capacitor is used in Figure 7. The ceramic capacitors should be placed as close as possible to  $+V_S$  and  $-V_S$  power supply pins.

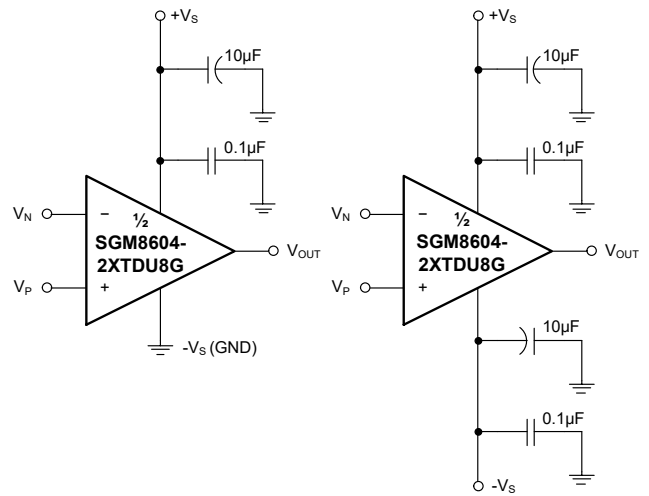

**Figure 7. Amplifier Power Supply Bypassing**

**REVISION HISTORY**

NOTE: Page numbers for previous revisions may differ from page numbers in the current version.

**Changes from Original (AUGUST 2021) to REV.A**

**Page**

---

Changed from product preview to production data.....All

---

# PACKAGE INFORMATION

## PACKAGE OUTLINE DIMENSIONS

### TDFN-3x3-8AL

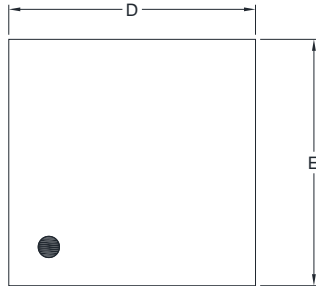

TOP VIEW

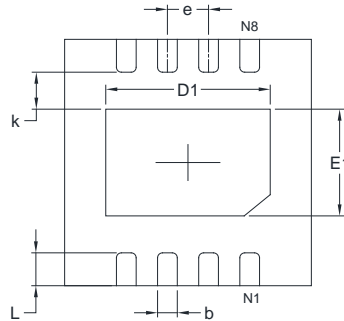

BOTTOM VIEW

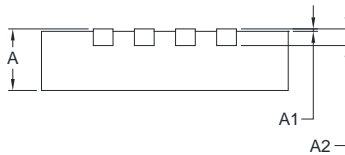

SIDE VIEW

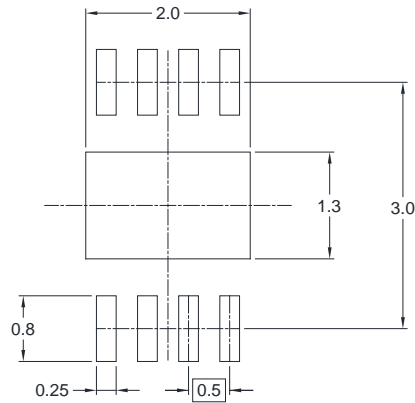

RECOMMENDED LAND PATTERN (Unit: mm)

Symbol	Dimensions In Millimeters		Dimensions In Inches	
	MIN	MAX	MIN	MAX
A	0.700	0.800	0.028	0.031
A1	0.000	0.050	0.000	0.002
A2	0.203 REF		0.008 REF	
D	2.900	3.100	0.114	0.122
D1	1.900	2.100	0.075	0.083
E	2.900	3.100	0.114	0.122
E1	1.200	1.400	0.047	0.055
k	0.350 REF		0.014 REF	
b	0.200	0.300	0.008	0.012
e	0.500 TYP		0.020 TYP	
L	0.400	0.600	0.016	0.024

# PACKAGE INFORMATION

## TAPE AND REEL INFORMATION

### REEL DIMENSIONS

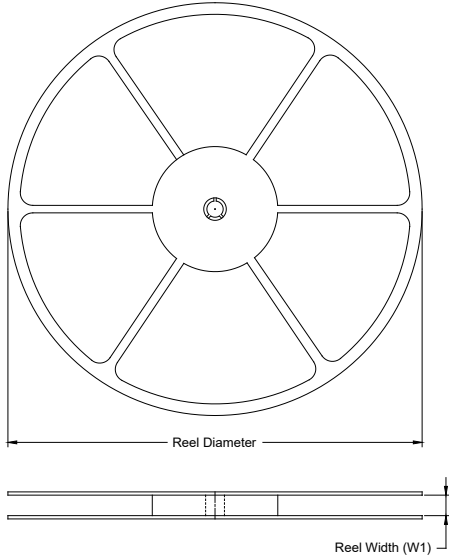

### TAPE DIMENSIONS

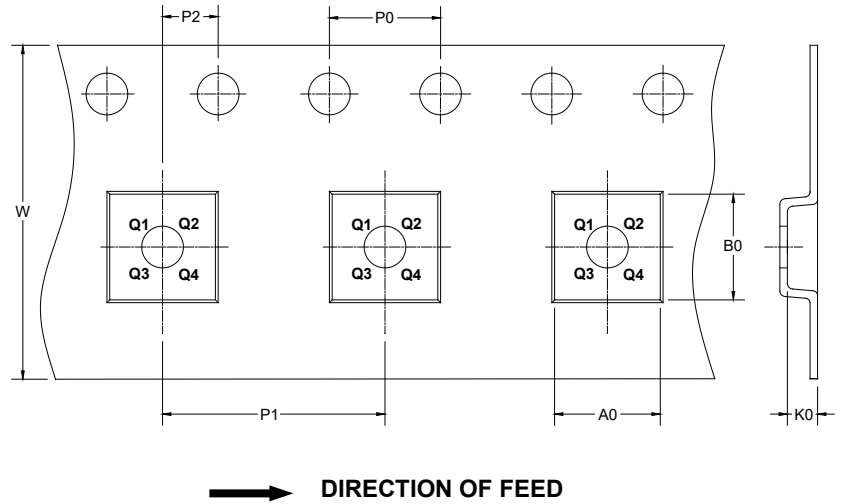

NOTE: The picture is only for reference. Please make the object as the standard.

### KEY PARAMETER LIST OF TAPE AND REEL

Package Type	Reel Diameter	Reel Width W1 (mm)	A0 (mm)	B0 (mm)	K0 (mm)	P0 (mm)	P1 (mm)	P2 (mm)	W (mm)	Pin1 Quadrant
TDFN-3×3-8AL	13"	12.4	3.35	3.35	1.13	4.0	8.0	2.0	12.0	Q2

DD0001

# PACKAGE INFORMATION

## CARTON BOX DIMENSIONS

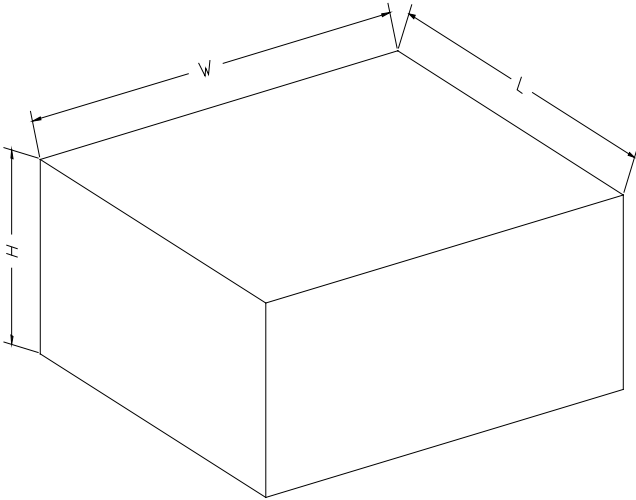

NOTE: The picture is only for reference. Please make the object as the standard.

## KEY PARAMETER LIST OF CARTON BOX

Reel Type	Length (mm)	Width (mm)	Height (mm)	Pizza/Carton
13"	386	280	370	5

DD0002