

GENERAL DESCRIPTION

The SGM66099B is an ultra-low quiescent current synchronous boost converter. 1.15V to 5.2V operation input voltage is suitable for Li-Mn battery, NiMH and Li-Ion rechargeable batteries. The 1.7µA (TYP) quiescent current maximizes the light load efficiency and also increases the effective battery operation time. In addition, the high-side synchronous rectifier provides output disconnect feature which minimizes unnecessary current drawn from the battery during shutdown mode.

The SGM66099B is able to deliver 300mA output current from 3.3V to 5V conversion, and achieves up to 93% efficiency at 200mA load.

The device offers down mode where the desired output voltage is regulated even when input voltage is higher than the output. In addition, when the input voltage is 300mV above the output voltage set point, the device enters pass-through mode.

The device integrates various protection features such as over-current protection, over-voltage protection and thermal shutdown. In addition, the synchronous rectifier supports short circuit protection which further improves the robustness of the device.

The SGM66099B offers both adjustable output voltage and fixed output voltage versions. It is available in Green WLCSP-1.22×0.83-6B and TDFN-2×2-6AL packages.

FEATURES

- **Operating Input Voltage Range: 1.15V to 5.2V**
- **Ultra-Low Quiescent Current**
 - ◆ 1.7µA (TYP) Ultra-Low I_Q into VOUT Pin
 - ◆ 0.05µA (TYP) Ultra-Low I_Q into VIN Pin
- **1.2MHz Fixed Frequency Operation**
- **Adjustable Output Voltage from 2.5V to 5.2V**
- **5.0V Fixed Output Voltage Version**
- **Power-Save Mode for Improved Efficiency at Low Output Power**
- **Regulated Output Voltage in Down Mode**
- **True Disconnection During Shutdown**
- **Up to 93% Efficiency from 10mA to 300mA Load**
- **-40°C to +85°C Operating Temperature Range**
- **Available in Green WLCSP-1.22×0.83-6B and TDFN-2×2-6AL Packages**

APPLICATIONS

- Memory LCD Bias
- Optical Heart Rate Monitor LED Bias
- Wearable Applications
- Low Power Wireless Applications
- Portable Products
- Battery Powered Systems

TYPICAL APPLICATION

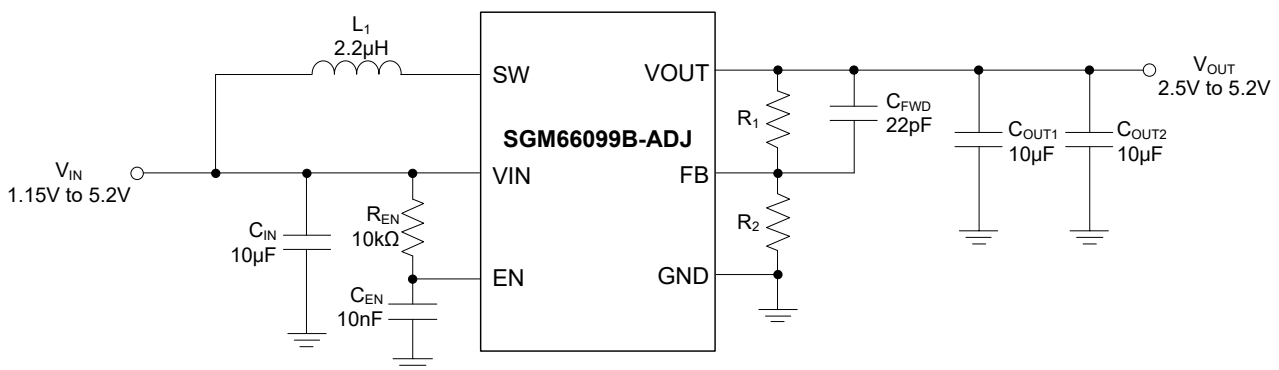

Figure 1. Typical Application Circuit

PACKAGE/ORDERING INFORMATION

MODEL	PACKAGE DESCRIPTION	SPECIFIED TEMPERATURE RANGE	ORDERING NUMBER	PACKAGE MARKING	PACKING OPTION
SGM66099B-5.0	WLCSP-1.22×0.83-6B	-40°C to +85°C	SGM66099B-5.0YG/TR	K8XX	Tape and Reel, 3000
	TDFN-2×2-6AL	-40°C to +85°C	SGM66099B-5.0YTDI6G/TR	CGA XXXX	Tape and Reel, 3000
SGM66099B-ADJ	WLCSP-1.22×0.83-6B	-40°C to +85°C	SGM66099B-ADJYG/TR	G8XX	Tape and Reel, 3000
	TDFN-2×2-6AL	-40°C to +85°C	SGM66099B-ADJYTDI6G/TR	CH0 XXXX	Tape and Reel, 3000

MARKING INFORMATION

NOTE: XX = Date Code. XXXX = Date Code and Trace Code.

WLCSP-1.22×0.83-6B

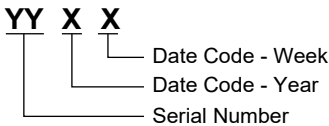

TDFN-2×2-6AL

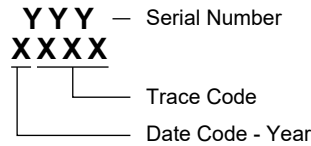

Green (RoHS & HSF): SG Micro Corp defines "Green" to mean Pb-Free (RoHS compatible) and free of halogen substances. If you have additional comments or questions, please contact your SGMICRO representative directly.

ABSOLUTE MAXIMUM RATINGS

- VIN, SW, VOUT, FB, EN to GND..... -0.3V to 6.0V
- Package Thermal Resistance
- WLCSP-1.22×0.83-6B, θ_{JA} 143°C/W
- TQFN-2×2-6AL, θ_{JA} 105°C/W
- Junction Temperature.....+150°C
- Storage Temperature.....-65°C to +150°C
- Lead Temperature (Soldering, 10s).....+260°C
- ESD Susceptibility
- HBM.....4000V
- CDM 1000V

RECOMMENDED OPERATING CONDITIONS

- Input Voltage Range 1.15V ⁽¹⁾ to 5.2V
- Output Voltage Range2.5V to 5.2V
- Operating Ambient Temperature Range.....-40°C to +85°C
- Operating Junction Temperature Range.....-40°C to +125°C

NOTE 1: Refer to the "Start-Up and Low Supply Voltage Operation" for detailed description.

OVERSTRESS CAUTION

Stresses beyond those listed in Absolute Maximum Ratings may cause permanent damage to the device. Exposure to absolute maximum rating conditions for extended periods may affect reliability. Functional operation of the device at any conditions beyond those indicated in the Recommended Operating Conditions section is not implied.

ESD SENSITIVITY CAUTION

This integrated circuit can be damaged by ESD if you don't pay attention to ESD protection. SGMICRO recommends that all integrated circuits be handled with appropriate precautions. Failure to observe proper handling and installation procedures can cause damage. ESD damage can range from subtle performance degradation to complete device failure. Precision integrated circuits may be more susceptible to damage because very small parametric changes could cause the device not to meet its published specifications.

DISCLAIMER

SG Micro Corp reserves the right to make any change in circuit design, or specifications without prior notice.

PIN CONFIGURATIONS

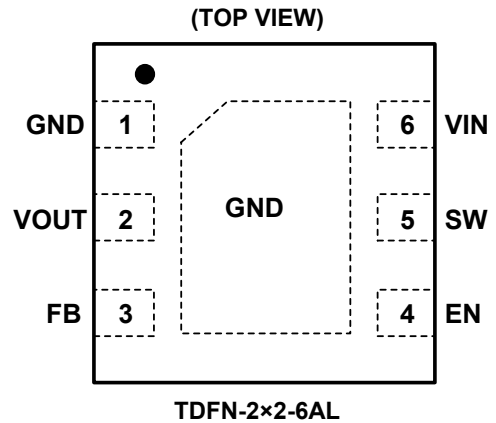
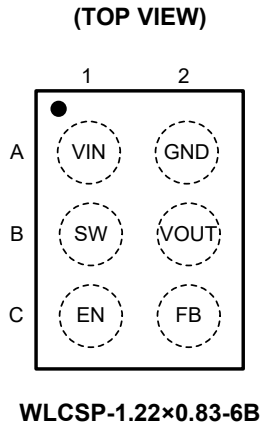

PIN DESCRIPTION

PIN		NAME	TYPE	FUNCTION
WLCSP-1.22x0.83-6B	TDFN-2x2-6AL			
A1	6	VIN	P	Power Supply Input.
A2	1	GND	G	Ground.
B1	5	SW	O	Switch Pin of the Converter. It is connected to the inductor.
B2	2	VOUT	O	Boost Converter Output.
C1	4	EN	I	Enable Logic Input. Logic high voltage enables the device; logic low voltage disables the device. Do not leave it floating.
C2	3	FB	I	Voltage Feedback of Adjustable Output Voltage. Connect to the center tap of a resistor divider to program the output voltage. Connect to the GND pin for fixed output voltage version and do not leave FB pin floating.
—	Exposed Pad	GND	—	Connect to GND.

NOTE: I: input, O: output, G: ground, P: power for the circuit.

ELECTRICAL CHARACTERISTICS

($V_{IN} = 1.15V$ to $5.2V$, $C_{IN} = 10\mu F$, $C_{OUT} = 20\mu F$. Full = $-40^{\circ}C$ to $+85^{\circ}C$, typical values are at $V_{IN} = 3.7V$, $T_A = +25^{\circ}C$, unless otherwise noted.)

PARAMETER	SYMBOL	CONDITIONS	TEMP	MIN	TYP	MAX	UNITS
Power Supply							
Input Voltage Range	V_{IN}		$+25^{\circ}C$	1.15		5.2	V
Quiescent Current into VIN Pin	I_Q	No load, not switching	Full		0.05	0.30	μA
Quiescent Current into VOUT Pin		No load, not switching, boost or down mode (SGM66099B-ADJ)	Full		1.7	7.0	μA
		No load, not switching, boost or down mode (SGM66099B-5.0)	Full		12	22	μA
Shutdown Current into VIN Pin	I_{SD}	EN = GND, $V_{IN} = 3.6V$	Full		0.1	1.0	μA
Output							
Output Voltage Range	V_{OUT}		Full	2.5		5.2	V
Output Voltage		SGM66099B-5.0, $V_{IN} < V_{OUT}$, PWM mode	Full	4.84	5.00	5.10	V
		SGM66099B-5.0, $V_{IN} < V_{OUT}$, PFM mode	$+25^{\circ}C$		5.02		V
Feedback Reference Voltage	V_{REF}	$V_{IN} < V_{OUT}$, PWM mode	Full	0.965	1.000	1.038	V
		$V_{IN} < V_{OUT}$, PFM mode	$+25^{\circ}C$		1.010		V
Output Over-Voltage Protection Threshold	V_{OVP}	V_{OUT} rising (WLCSP)	$+25^{\circ}C$	5.30	5.70	5.87	V
		V_{OUT} rising (TDFN)	$+25^{\circ}C$	5.23	5.70	5.99	
OVP Hysteresis			$+25^{\circ}C$		100		mV
Leakage Current into FB Pin	I_{FB_LKG}	$V_{FB} = 1.1V$	Full		10	50	nA
Switching							
Switching Frequency	f_{SW}	$V_{IN} = 3.7V$	Full	0.9	1.2	1.55	MHz
Power Switch							
Low-side Switch On-Resistance	$R_{DS(ON)_LS}$	$V_{OUT} = 4.7V$ (TDFN)	$+25^{\circ}C$		280	400	m Ω
		$V_{OUT} = 4.7V$ (WLCSP)	$+25^{\circ}C$		230	330	m Ω
		$V_{OUT} = 3.3V$ (TDFN)	$+25^{\circ}C$		340	480	m Ω
		$V_{OUT} = 3.3V$ (WLCSP)	$+25^{\circ}C$		290	400	m Ω
Rectifier On-Resistance	$R_{DS(ON)_HS}$	$V_{OUT} = 4.7V$ (TDFN)	$+25^{\circ}C$		270	380	m Ω
		$V_{OUT} = 4.7V$ (WLCSP)	$+25^{\circ}C$		250	360	m Ω
		$V_{OUT} = 3.3V$ (TDFN)	$+25^{\circ}C$		350	490	m Ω
		$V_{OUT} = 3.3V$ (WLCSP)	$+25^{\circ}C$		330	470	m Ω
Current Limit Threshold	I_{LIM}		$+25^{\circ}C$	0.90	1.30	1.64	A
Control Logic							
EN Input Low Voltage Threshold	V_{IL}	$V_{IN} \leq 1.5V$	Full			$0.14 \times V_{IN}$	V
		$V_{IN} > 1.5V$	Full			0.3	V
EN Input High Voltage Threshold	V_{IH}	$V_{IN} \leq 1.5V$	Full	$0.8 \times V_{IN}$			V
		$V_{IN} > 1.5V$	Full	1.2			V
Leakage Current into EN Pin	I_{EN_LKG}	$V_{EN} = 5.0V$	$+25^{\circ}C$			300	nA
Thermal Shutdown Threshold					150		$^{\circ}C$
Thermal Shutdown Hysteresis					25		$^{\circ}C$

TYPICAL PERFORMANCE CHARACTERISTICS

C_{IN} = 10μF and C_{OUT} = 20μF, unless otherwise noted.

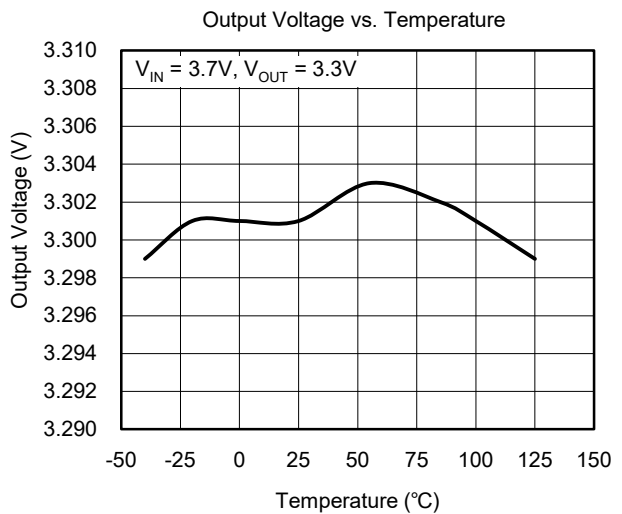
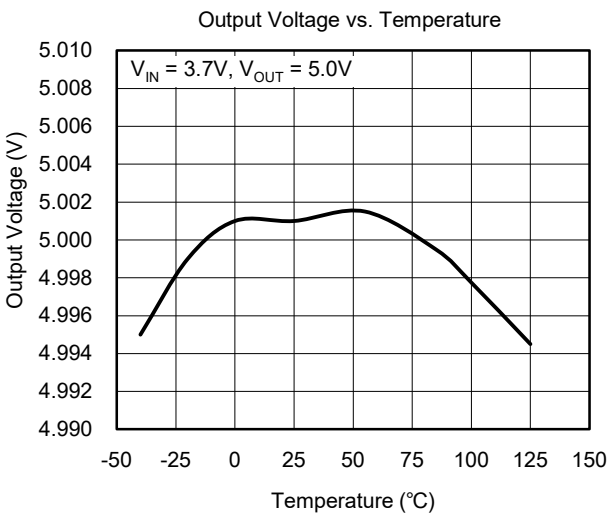
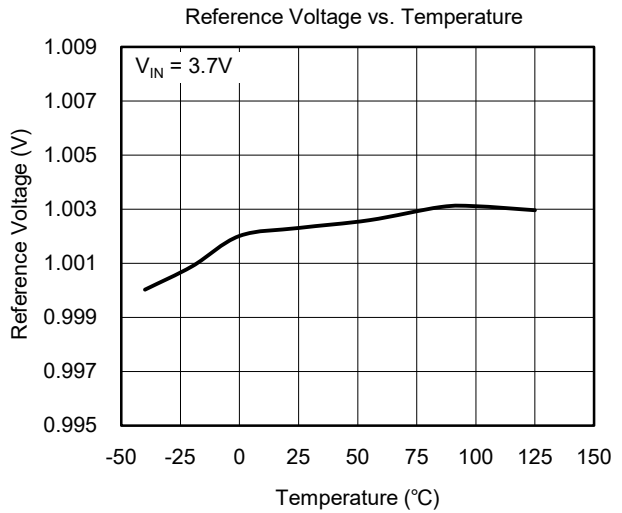
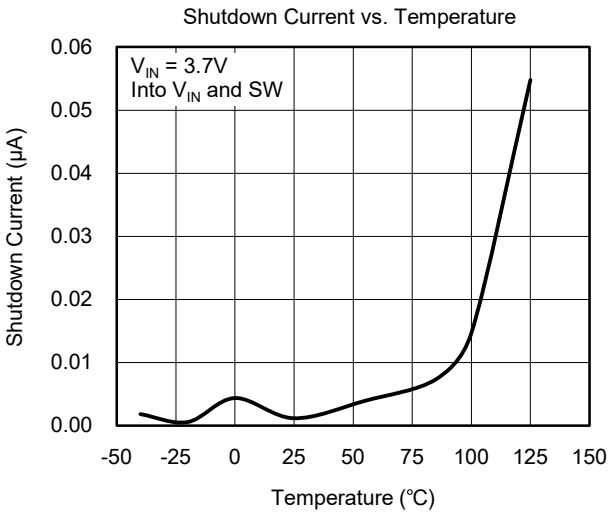
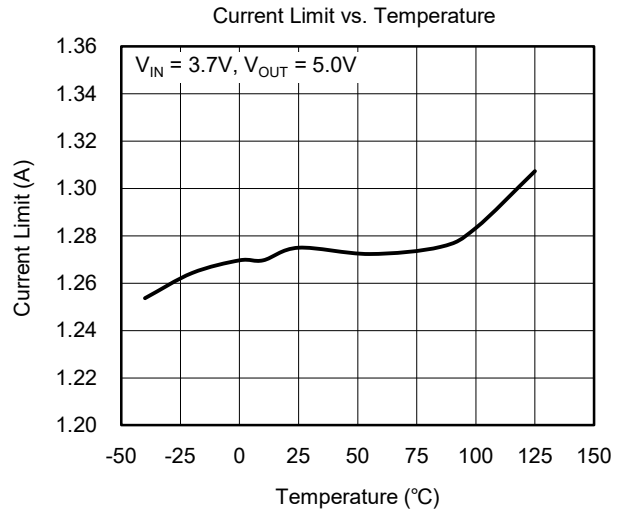
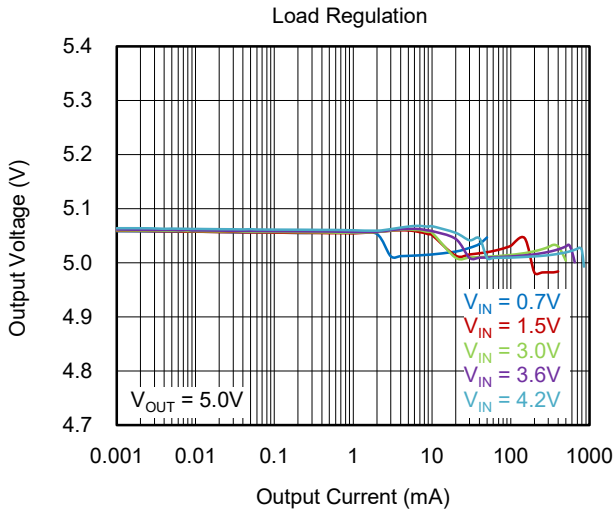

TYPICAL PERFORMANCE CHARACTERISTICS (continued)

$C_{IN} = 10\mu F$ and $C_{OUT} = 20\mu F$, unless otherwise noted.

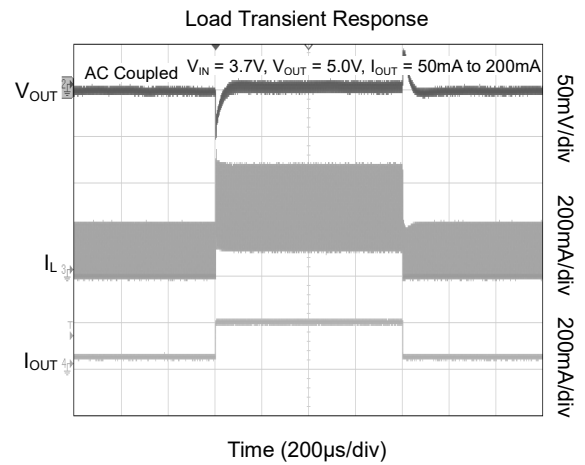
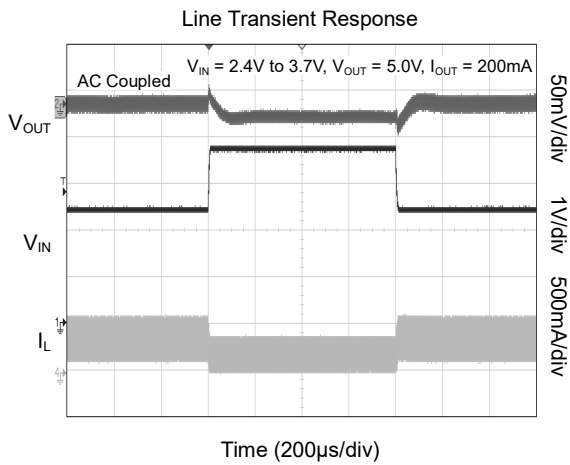
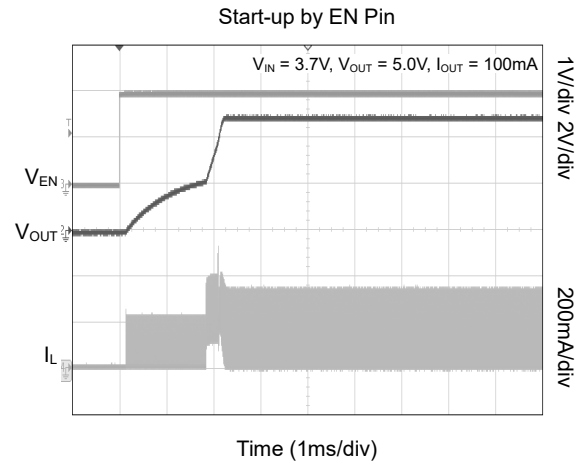
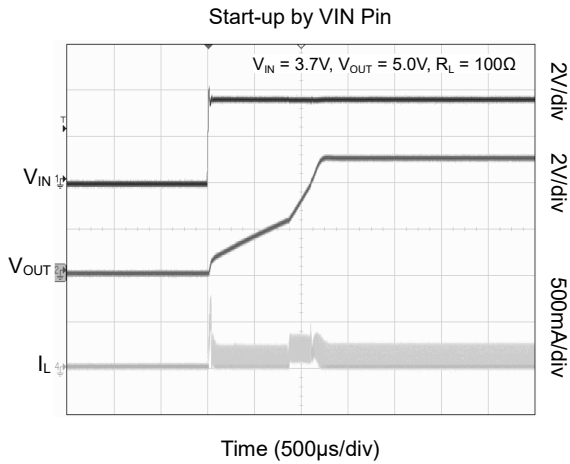
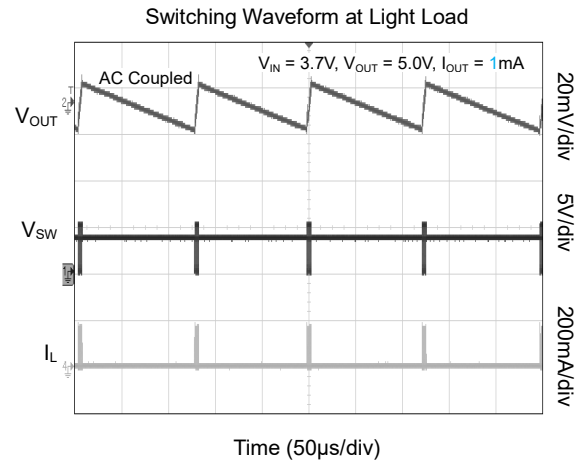
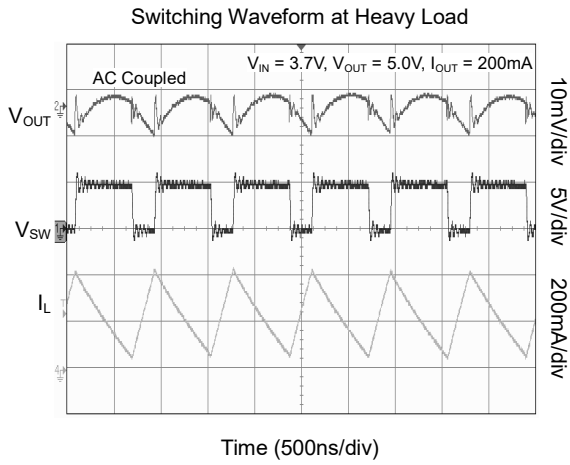

TYPICAL PERFORMANCE CHARACTERISTICS (continued)

C_{IN} = 10μF and C_{OUT} = 20μF, unless otherwise noted.

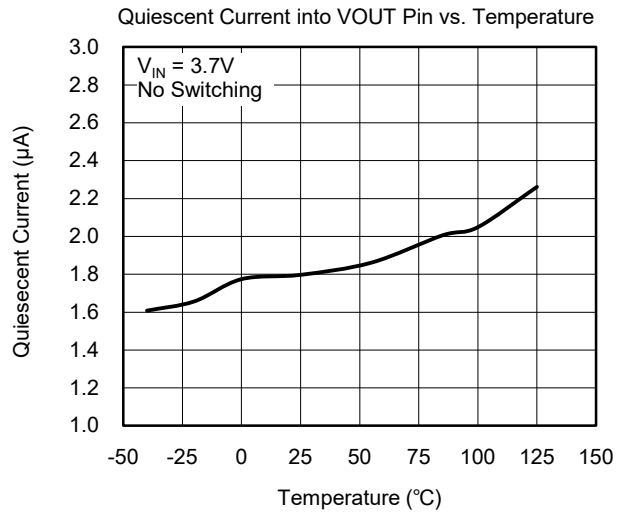
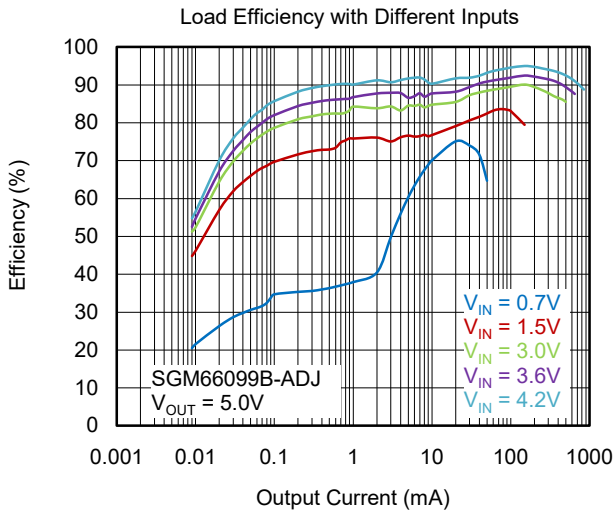
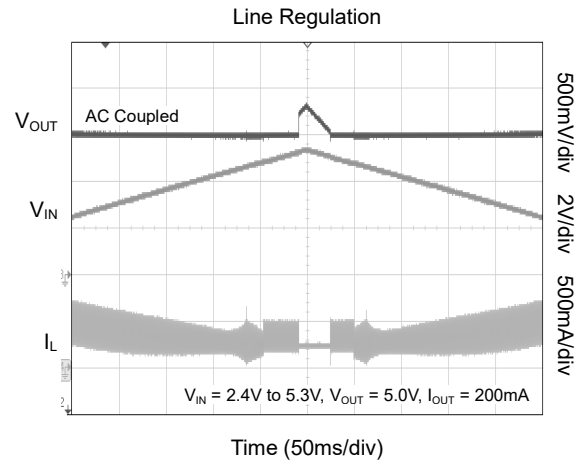
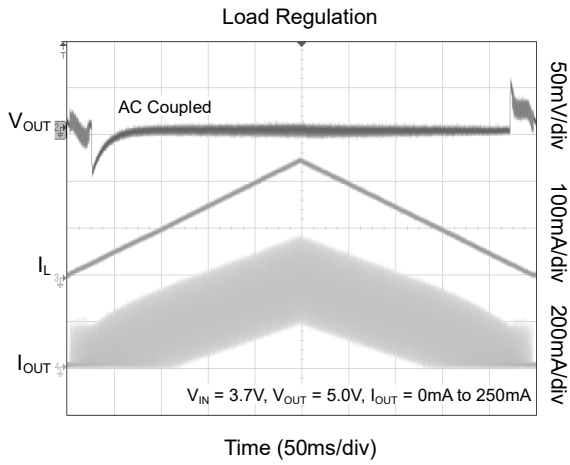

FUNCTIONAL BLOCK DIAGRAM

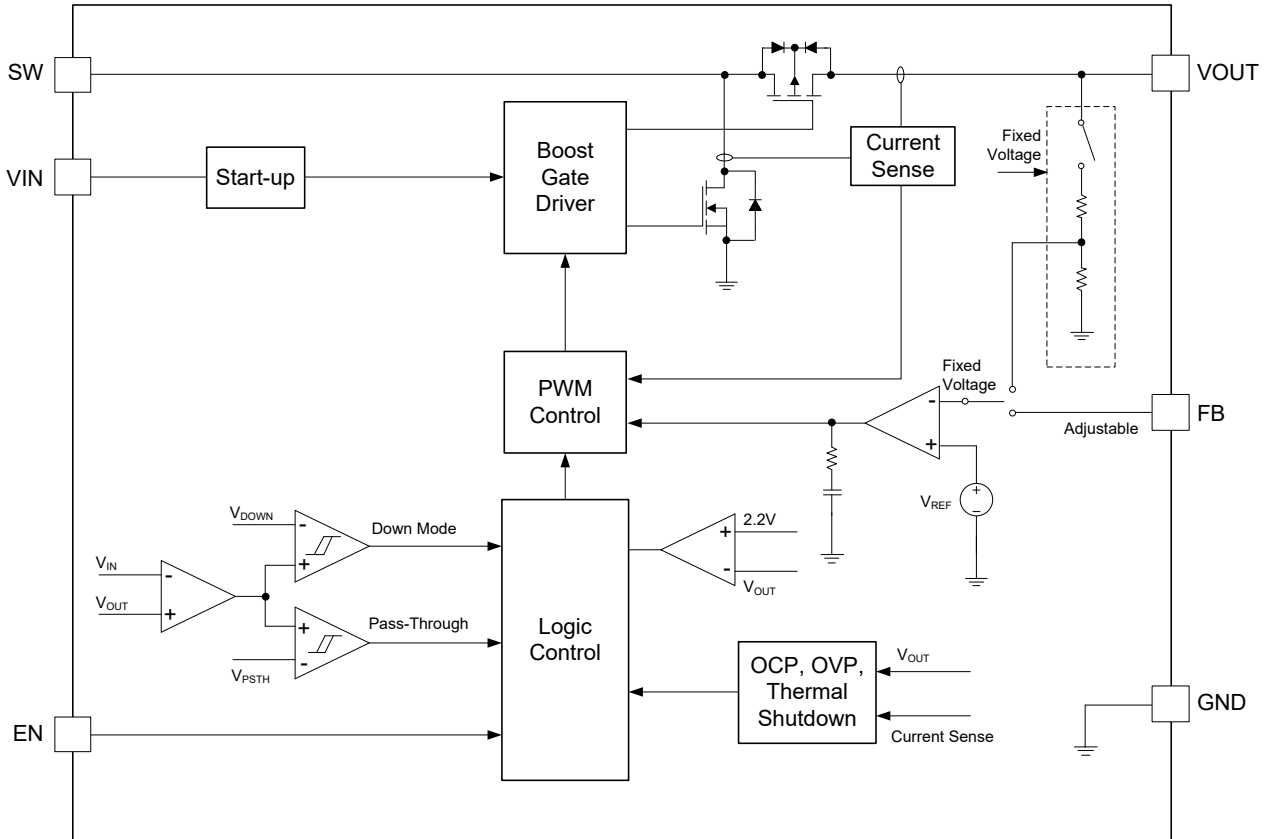

Figure 2. Block Diagram

DETAILED DESCRIPTION

The SGM66099B synchronous boost converter is designed for Li-Ion battery powered systems, where the compact solution size and battery operation time are key criterions. The device can operate with a wide input voltage from 1.15V to 5.2V. The 1.7 μ A (TYP) quiescent current and light load power-save mode further improve the system efficiency.

The device employs peak current mode with typical 1.3A (TYP) peak switch current limit. The device provides the true shutdown function, where the load is completely disconnected from the input to minimize the leakage current. The integrated down mode and pass-through mode ensure a smooth operation when input voltage is close to or higher than the set output voltage. Adjustable version offers programmable output voltage for flexible applications while fixed versions offer minimal solution size.

Enable and Disable

When the EN pin is pulled to high, the SGM66099B is enabled. When the EN pin is pulled to low, the SGM66099B goes into shutdown mode. In shutdown mode, the device stops switching and the rectifying PMOS is fully turned off, providing a complete disconnection between input and output. Less than 1 μ A input current is consumed in shutdown mode. In particular, it is recommended to avoid pulling EN high to start the boost when the power supply voltage is higher than 5.2V. See Figure 1, a RC network of 10k Ω and 10nF at EN pin is suggested to ensure the EN active signal a bit later than the spike of the power supply.

Start-Up and Low Supply Voltage Operation

The SGM66099B is able to start up with 1.15V input voltage with larger than 3k Ω load. Before the output voltage reaches 2.2V during the start-up phase, the switch current is limited to about 200mA. Therefore, if the load during start-up is too heavy, the device will fail to charge the output voltage to above 2.2V after soft-start time expires, and it will not be able to start up successfully.

The SGM66099B may not be shut down by pulling the EN to logic low when the supply voltage is below 0.85V, while the supply voltage can drop to as low as 0.3V for maintain the output voltage with light loadings.

Current Limit Operation

The SGM66099B employs a cycle-by-cycle over-current protection (OCP). If the inductor peak current reaches the current limit threshold I_{LIM} , the main switch is turned off to prevent the inductor current from further increase. In this case the output voltage will decrease until the power balance between input and output is achieved. If the current limit causes the output to drop below the input voltage, the SGM66099B enters into down mode, where the peak current is still limited by I_{LIM} cycle-by-cycle. If the output continues dropping below 2.2V, the SGM66099B enters into start-up process again. In pass-through mode, current limit function is not enabled.

Output Short-to-Ground Protection

During the output short-to-ground case, the SGM66099B starts to limit the switch current to about 200mA when the output voltage drops below 2.2V. Once the short circuit is released, the device goes back to soft-start again and regulates the output voltage.

Over-Voltage Protection

SGM66099B integrates over-voltage protection (OVP) to protect the device in case of feedback resistor short-to-ground or incorrect feedback resistor value being populated. When the output voltage of the SGM66099B exceeds the OVP threshold of 5.7V (TYP), the device stops switching. The device implements 100mV OVP hysteresis. When the output voltage is 100mV lower than the OVP threshold, the device resumes switching.

Power-Save Mode under Light Load Condition

The SGM66099B enters into power-save mode under light load condition.

Down Mode Regulation and Pass-Through Mode

SGM66099B offers down mode feature where the device can still regulate the set output voltage even when the input voltage is higher than output voltage. If the input voltage continues increasing in down mode, the device automatically enters pass-through mode. Care should be taken in pass-through mode, where the input voltage should not exceed the recommended maximum input voltage.

DETAILED DESCRIPTION (continued)

In down mode, the control logic pulls the gate of PMOS to the input voltage rather than ground. This method allows effective control of inductor current when $V_{IN} > V_{OUT}$. Thermal consideration should be taken in down mode, where the voltage drop across the PMOS increases as the delta of V_{IN} and V_{OUT} increases.

In pass-through mode, the complimentary switching action stops. The gate of PMOS is pulled to ground for always-on and the low-side switch remains off. The output voltage is the input voltage minus the voltage drop across the DC resistance (DCR) of the inductor and the on-resistance of the rectifying PMOS.

SGM66099B enters down mode when the input voltage is equal to or higher than $V_{OUT} - 100mV$. It remains in down mode until $V_{IN} > V_{OUT} + 0.3V$ and then goes automatically into pass-through mode. In pass-through mode, the high-side PMOS is always turned on to pass the input voltage to the output. The SGM66099B exits pass-through mode and goes back to down mode when V_{IN} ramps down to 101% of the target output voltage. It

stays in down mode until input voltage falls 150mV below the output voltage, returning to boost operation.

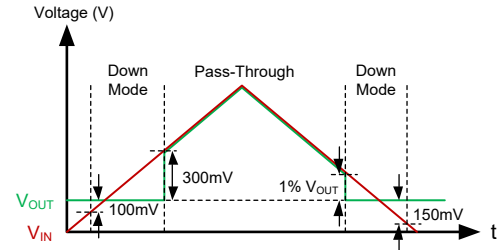

Figure 3. Down Mode and Pass-Through Mode

Thermal Shutdown

A thermal shutdown function is implemented to prevent damage caused by excessive heat and power dissipation. Once a junction temperature of typically +150°C (TYP) is exceeded, the device is shut down. The device is released from shutdown automatically when the junction temperature decreases by 25°C.

APPLICATION INFORMATION

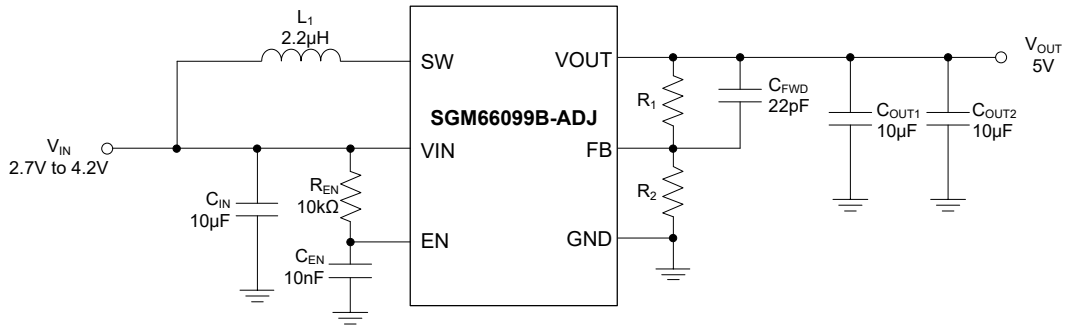

Figure 4. 5V Output Boost Converter

Design Requirements

5V output at 1mA load current is used to provide system bias power or LED bias voltage from a single cell Li-Ion battery as an example. The following design procedure can be used to select external component values for the SGM66099B-ADJ.

Table 1. Design Requirements

PARAMETERS	VALUES
Input Voltage	2.7V ~ 4.2V
Output Voltage	5V
Output Current	1mA
Output Voltage Ripple	±50mV

Programming the Output Voltage

An external resistor divider (R₁ and R₂ in Figure 4) can be used to set the output voltage. The typical voltage at the FB pin is V_{REF} of 1.0V.

$$V_{OUT} = V_{REF} \times \frac{R_1 + R_2}{R_2} \tag{1}$$

The leakage current into the FB pin affects the accuracy of output voltage. To minimize the leakage current effect, the current flowing through R₂ should be 100 times larger than FB pin leakage current. Small R₂ increases the noise immunity, while large R₂ reduces the leakage current flowing through feedback resistors, which improves the no load efficiency of the device.

1MΩ and 249kΩ resistors are selected for R₁ and R₂ respectively in this case. ±1% accuracy resistors are recommended for R₁ and R₂ to improve output voltage accuracy.

An external feed-forward capacitor (C_{FWD}) from 10pF to 22pF in parallel with R₁ is recommended to improve device’s stability.

For fixed output voltage version, connect the FB pin to GND and do not leave FB pin floating.

Maximum Output Current

The maximum output load capability of SGM66099B depends on the minimum desired operation input voltage and the current limit of the device. The maximum load current can be estimated by Equation 2,

$$I_{OUT(MAX)} = \frac{V_{IN} \cdot (I_{LIM} - \frac{I_{LH}}{2}) \cdot \eta}{V_{OUT}} \tag{2}$$

where η is the conversion efficiency, using 85% for estimation. I_{LH} is the inductor peak-to-peak ripple current and I_{LIM} is the switch current limit.

For worst-case condition analysis, minimum input voltage, maximum boost output voltage and minimum current limit I_{LIM} should be used.

APPLICATION INFORMATION (continued)

Inductor Selection

Inductor selection is one of the most important criteria for switch mode power supply, because the inductor selection may affect the power supply's transient response, loop stability, efficiency and steady-state operation. Inductor parameters of DC resistance (DCR), inductance and saturation current are critical for a smooth and efficient power supply operation.

The internal compensation of the device is optimized with 1 μ H and 2.2 μ H. When V_{OUT} is higher than 3V, 2.2 μ H inductance should be selected. When V_{OUT} is less than 3V, 1.1 μ H inductance should be selected.

Capacitor Selection

The input capacitor of boost converter not only minimizes input voltage ripple, but also reduces any voltage spike presenting on IC's VIN pin. A 10 μ F, low ESR and X5R or higher temperature coefficient ceramic capacitor is recommended to place as close to the VIN and GND pins as possible to improve transient response and EMI behavior.

Boost converter's output capacitor plays a significant role in ensuring good system performance. The location of output capacitor will have an effect on the switching spikes on the SW pin, which ultimately affects EMI performance and potentially damages the IC due to large switching spikes. The current loop formed by the output capacitor flowing from the VOUT pin and back to the GND pin should be as small as possible.

Therefore, a ceramic cap should be placed as close to the VOUT and GND pins of the IC as possible.

Boost topology presents right-half-plane-zero which is dictated by inductance. In addition, the output capacitor sets the corner frequency of the converter for current mode controlled method. Consequently, with a larger inductor, a larger output capacitor must be used. The device's internal compensation is optimized to operate with inductance values between 1 μ H and 2.2 μ H, resulting in the minimum output capacitor value of 20 μ F (nominal value). Increasing the output capacitor can reduce output ripple in PWM mode.

Due to the nature of ceramic capacitors' DC bias effect, effective capacitance at the bias voltage should be verified. GRM188R60J106ME84D, which is a 10 μ F ceramic capacitor with high effective capacitance value at DC biased condition, is selected for V_{OUT} rail.

In the case of load hot-plugging, the input capacitance of load device needs to be less than 1/10 of the output capacitance of SGM66099B.

Layout

In addition to component selection, layout is a critical step to ensure the performance of any switch mode power supplies. Poor layout could result in system instability, EMI failure, and device damage. Thus, place the inductor, input and output capacitors as close to the IC as possible, and use wide and short traces for current carrying traces to minimize PCB inductance.

Table 2. List of Inductors

V_{OUT} (V)	Inductance (μ H)	Saturation Current (A)	DC Resistance (m Ω)	Size (L x W x H)	Part Number	Manufacturer
> 3.0	2.2	1.95	80	2.5 x 2.0 x 1.2	74404024022	Würth Elektronik
	2.2	1.7	92	2.5 x 2.0 x 1.1	LQH2HPN2R2MJR	muRata
	2.2	1.45	163	2.0 x 1.6 x 1.0	VLS201610CX-2R2M	TDK
\leq 3.0	1.0	2.6	37	2.5 x 2.0 x 1.2	74404024010	Würth Elektronik
	1.0	2.3	48	2.5 x 2.0 x 1.0	MLP2520W1R0MT0S1	TDK
	1.0	1.5	80	2.0 x 1.2 x 1.0	LQM21PN1R0MGH	muRata

REVISION HISTORY

NOTE: Page numbers for previous revisions may differ from page numbers in the current version.

AUGUST 2021 – REV.A.2 to REV.A.3	Page
Updated Figure 1 and Application Information section	1, 11
<hr/>	
JULY 2021 – REV.A.1 to REV.A.2	Page
Updated the Functional Block Diagram and product description sections	1, 8, 9, 10, 11, 12
<hr/>	
FEBRUARY 2021 – REV.A to REV.A.1	Page
Updated FB pin function	3, 11
<hr/>	
Changes from Original (JUNE 2020) to REV.A	Page
Changed from product preview to production data.....	All

PACKAGE OUTLINE DIMENSIONS

WLCSP-1.22x0.83-6B

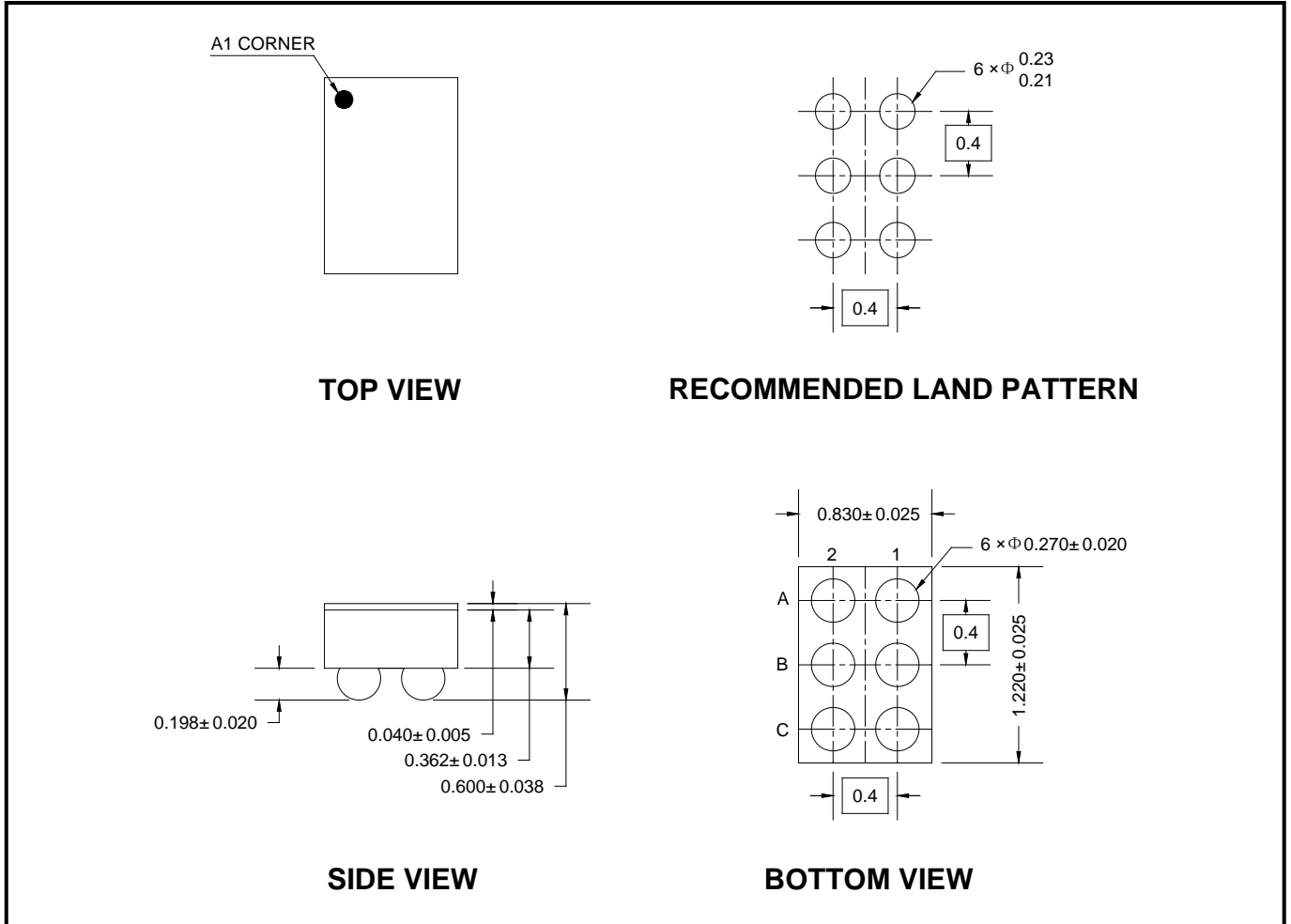

NOTE: All linear dimensions are in millimeters.

PACKAGE OUTLINE DIMENSIONS

TDFN-2x2-6AL

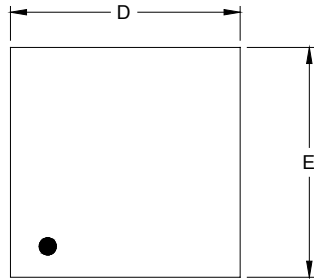

TOP VIEW

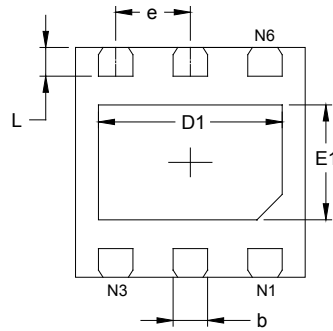

BOTTOM VIEW

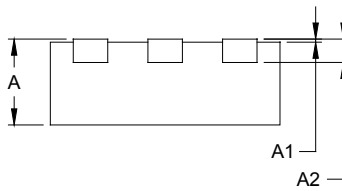

SIDE VIEW

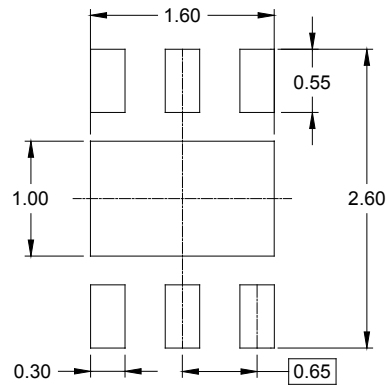

RECOMMENDED LAND PATTERN (Unit: mm)

Symbol	Dimensions In Millimeters		Dimensions In Inches	
	MIN	MAX	MIN	MAX
A	0.700	0.800	0.028	0.031
A1	0.000	0.050	0.000	0.002
A2	0.203 REF		0.008 REF	
D	1.900	2.100	0.075	0.083
D1	1.500	1.700	0.059	0.067
E	1.900	2.100	0.075	0.083
E1	0.900	1.100	0.035	0.043
b	0.250	0.350	0.010	0.014
e	0.650 BSC		0.026 BSC	
L	0.174	0.326	0.007	0.013

TAPE AND REEL INFORMATION

REEL DIMENSIONS

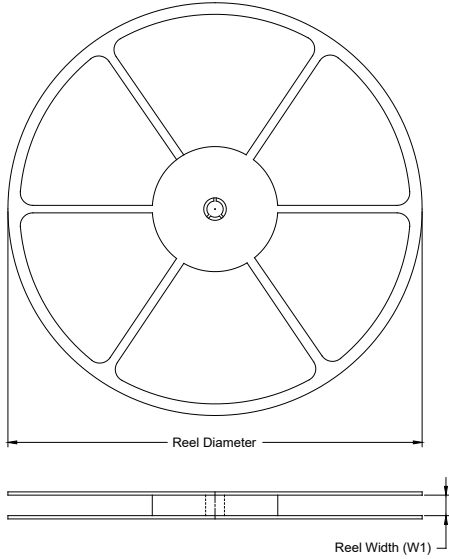

TAPE DIMENSIONS

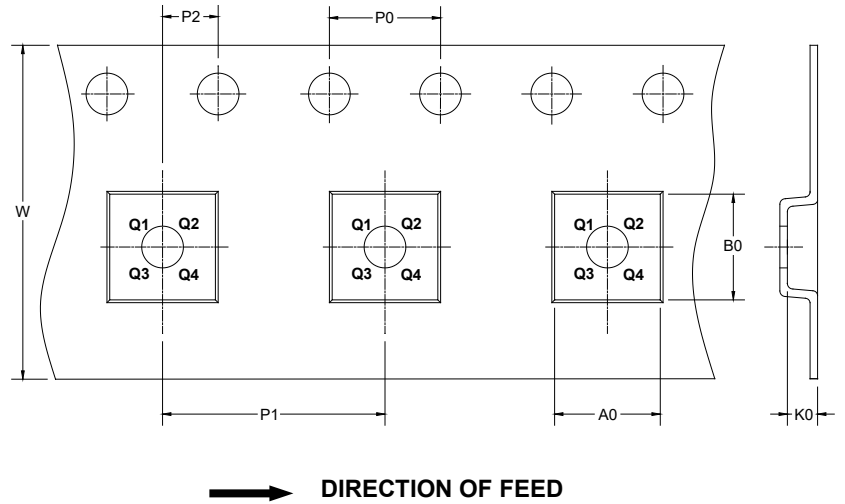

NOTE: The picture is only for reference. Please make the object as the standard.

KEY PARAMETER LIST OF TAPE AND REEL

Package Type	Reel Diameter	Reel Width W1 (mm)	A0 (mm)	B0 (mm)	K0 (mm)	P0 (mm)	P1 (mm)	P2 (mm)	W (mm)	Pin1 Quadrant
WLCSP-1.22×0.83-6B	7"	9.5	0.91	1.31	0.71	4.0	4.0	2.0	8.0	Q1
TDFN-2×2-6AL	7"	9.5	2.30	2.30	1.10	4.0	4.0	2.0	8.0	Q1

000001

PACKAGE INFORMATION

CARTON BOX DIMENSIONS

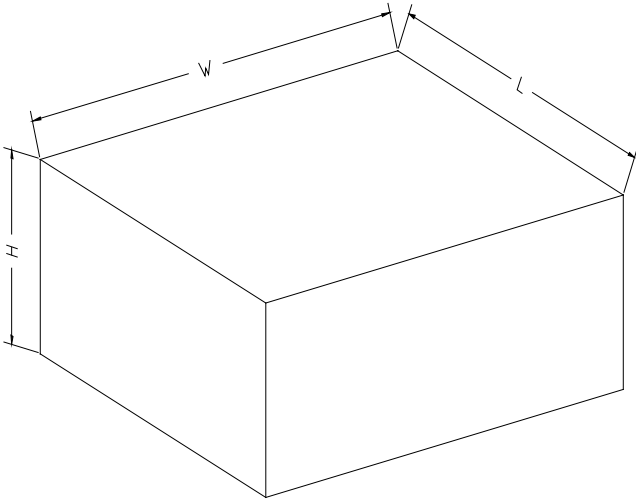

NOTE: The picture is only for reference. Please make the object as the standard.

KEY PARAMETER LIST OF CARTON BOX

Reel Type	Length (mm)	Width (mm)	Height (mm)	Pizza/Carton
7" (Option)	368	227	224	8
7"	442	410	224	18

DD0002