

GENERAL DESCRIPTION

The SGM431x is a three-terminal adjustable shunt regulator, with specified thermal stability over applicable commercial, industrial and extended industrial temperature ranges. The output voltage can be set to any value between V_{REF} (approximately 2.5V) and 36V, with two external resistors. The SGM431x has a typical output impedance of 0.1Ω. Active output circuitry provides a very sharp turn-on characteristic, making it an excellent replacement for Zener diodes in many applications, such as onboard regulation, adjustable power supplies and switching power supplies.

In addition, low output drift versus temperature ensures good stability over the entire temperature range.

The SGM431 is available in Green SOIC-8, SOT-23, SOT-89-3, SOT-23-5 and SC70-6 packages. The SGM431B is available in Green SOIC-8, SOT-23, SOT-89-3 and SOT-23-5 packages.

FEATURES

- **Reference Voltage Tolerance at +25°C:**
 - ◆ **SGM431: 1% (Standard Grade)**
 - ◆ **SGM431B: 0.5% (B Grade)**
- **Adjustable Output Voltage: V_{REF} to 36V**
- **High Stability under Capacitive Load**
- **Typical Temperature Drift: 5mV**
- **Low Output Noise**
- **Typical Output Impedance: 0.1Ω**
- **Sink-Current Capability: 1mA to 100mA**
- **Operating Junction Temperature Range: -40°C to +125°C**
- **The SGM431 is available in Green SOIC-8, SOT-23, SOT-89-3, SOT-23-5 and SC70-6 Packages**
- **The SGM431B is available in Green SOIC-8, SOT-23, SOT-89-3 and SOT-23-5 Packages**

APPLICATIONS

- Adjustable Voltage and Current Referencing
- Secondary Side Regulation in Flyback SMPSs
- Zener Replacement
- Voltage Monitoring
- Comparator with Integrated Reference

TYPICAL APPLICATION

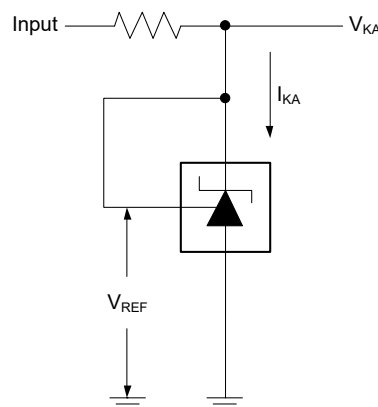

Figure 1. Typical Application Circuit

PACKAGE/ORDERING INFORMATION

MODEL	PACKAGE DESCRIPTION	SPECIFIED TEMPERATURE RANGE	ORDERING NUMBER	PACKAGE MARKING	PACKING OPTION
SGM431	SOIC-8	-40°C to +125°C	SGM431XS8G/TR	SGM 431XS8 XXXXX	Tape and Reel, 4000
	SOT-23	-40°C to +125°C	SGM431XN3LG/TR	MPCXX	Tape and Reel, 3000
	SOT-23-5	-40°C to +125°C	SGM431XN5G/TR	MPBXX	Tape and Reel, 3000
	SOT-89-3	-40°C to +125°C	SGM431XK3G/TR	SGM431X XXXXX	Tape and Reel, 1000
	SC70-6	-40°C to +125°C	SGM431XC6G/TR	CJEXX	Tape and Reel, 3000
SGM431B	SOIC-8	-40°C to +125°C	SGM431BXS8G/TR	SGM 431BXS8 XXXXX	Tape and Reel, 4000
	SOT-23	-40°C to +125°C	SGM431BXN3LG/TR	CY6XX	Tape and Reel, 3000
	SOT-23-5	-40°C to +125°C	SGM431BXN5G/TR	CY7XX	Tape and Reel, 3000
	SOT-89-3	-40°C to +125°C	SGM431BXK3G/TR	SGM431BX XXXXX	Tape and Reel, 1000

MARKING INFORMATION

NOTE: XX = Date Code, XXXXX = Date Code, Trace Code and Vendor Code.

SOT-23/SOT-23-5/SC70-6

YYY X X

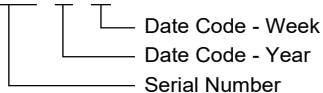

SOIC-8/SOT-89-3

XXXXX

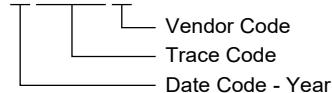

Green (RoHS & HSF): SG Micro Corp defines "Green" to mean Pb-Free (RoHS compatible) and free of halogen substances. If you have additional comments or questions, please contact your SGMICRO representative directly.

ABSOLUTE MAXIMUM RATINGS

Cathode Voltage ⁽¹⁾ , V_{KA}	40V
Package Thermal Resistance	
SOIC-8, θ_{JA}	126°C/W
SOT-23, θ_{JA}	245°C/W
SOT-23-5, θ_{JA}	210°C/W
SOT-89-3, θ_{JA}	71°C/W
SC70-6, θ_{JA}	210°C/W
Junction Temperature.....	+150°C
Storage Temperature Range.....	-65°C to +150°C
Lead Temperature (Soldering, 10s).....	+260°C
ESD Susceptibility	
HBM.....	4000V
CDM.....	1000V

RECOMMENDED OPERATING CONDITIONS

Cathode Voltage, V_{KA}	V_{REF} to 36V
Cathode Current, I_{KA}	1mA to 100mA
Operating Junction Temperature Range.....	-40°C to +125°C

NOTE:

1. All voltage values are with respect to ANODE, unless otherwise noted.

OVERSTRESS CAUTION

Stresses beyond those listed in Absolute Maximum Ratings may cause permanent damage to the device. Exposure to absolute maximum rating conditions for extended periods may affect reliability. Functional operation of the device at any conditions beyond those indicated in the Recommended Operating Conditions section is not implied.

ESD SENSITIVITY CAUTION

This integrated circuit can be damaged if ESD protections are not considered carefully. SGMICRO recommends that all integrated circuits be handled with appropriate precautions. Failure to observe proper handling and installation procedures can cause damage. ESD damage can range from subtle performance degradation to complete device failure. Precision integrated circuits may be more susceptible to damage because even small parametric changes could cause the device not to meet the published specifications.

DISCLAIMER

SG Micro Corp reserves the right to make any change in circuit design, or specifications without prior notice.

PIN CONFIGURATIONS

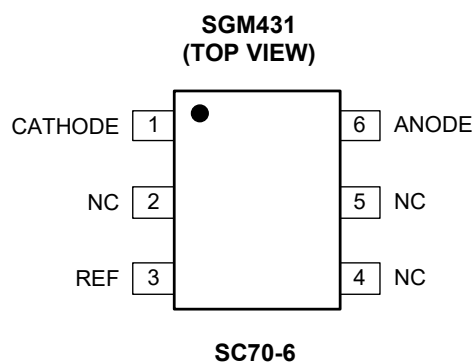
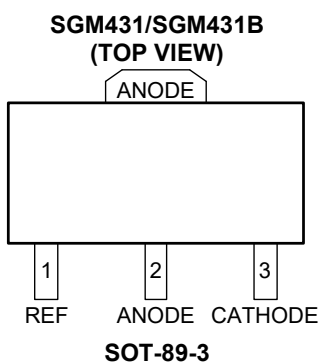
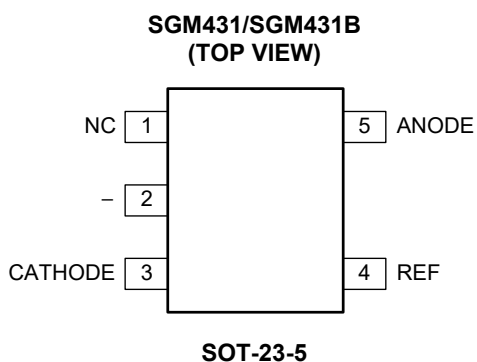
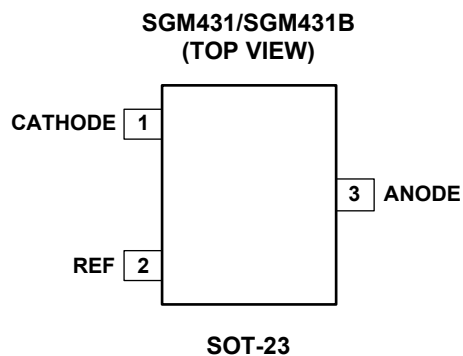
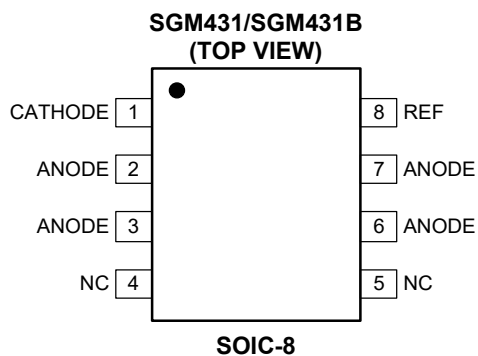

PIN DESCRIPTION

PIN					NAME	TYPE	DESCRIPTION
SOIC-8	SOT-23	SOT-23-5	SOT-89-3	SC70-6			
1	1	3	3	1	CATHODE	I/O	Shunt Current/Voltage Input.
2, 3, 6, 7	3	5	2	6	ANODE	O	Common Pin. Normally connected to ground.
4, 5	-	1	-	2, 4, 5	NC	-	Not Connected.
8	2	4	1	3	REF	I	Threshold Relative to Common Anode.
-	-	2	-	-	-	-	Pin 2 is attached to substrate and must be connected to anode or left open.

NOTE: I: input, O: output, I/O: input or output.

ELECTRICAL CHARACTERISTICS

(Over recommended operating conditions, T_J = +25°C, unless otherwise noted.)

PARAMETER	SYMBOL	CONDITIONS	MIN	TYP	MAX	UNITS
SGM431						
Reference Voltage	V _{REF}	V _{KA} = V _{REF} , I _{KA} = 10mA	2.475	2.500	2.525	V
Deviation of Reference Input Voltage over Full Temperature Range ⁽¹⁾	V _{I(DEV)}	V _{KA} = V _{REF} , I _{KA} = 10mA		5	25	mV
Ratio of Change in Reference Voltage to the Change in Cathode Voltage	ΔV _{REF} /ΔV _{KA}	I _{KA} = 10mA	ΔV _{KA} = 10V - V _{REF}	-0.5	-1.0	mV/V
			ΔV _{KA} = 36V - 10V	0.1	0.5	
Reference Input Current	I _{REF}	I _{KA} = 10mA, R ₁ = 10kΩ, R ₂ = ∞		1	2	μA
Deviation of Reference Input Current over Full Temperature Range ⁽¹⁾	I _{I(DEV)}	I _{KA} = 10mA, R ₁ = 10kΩ, R ₂ = ∞		0.4	0.8	μA
Minimum Cathode Current for Regulation	I _{MIN}	V _{KA} = V _{REF}		0.4	0.7	mA
Off-State Cathode Current	I _{OFF}	V _{KA} = 36V, V _{REF} = 0		0.1	1	μA
Dynamic Impedance ⁽²⁾	Z _{KA}	V _{KA} = V _{REF} , f ≤ 1kHz, I _{KA} = 1mA to 100mA		0.1	0.5	Ω
SGM431B						
Reference Voltage	V _{REF}	V _{KA} = V _{REF} , I _{KA} = 10mA	2.488	2.500	2.512	V
Deviation of Reference Input Voltage over Full Temperature Range ⁽¹⁾	V _{I(DEV)}	V _{KA} = V _{REF} , I _{KA} = 10mA		5	25	mV
Ratio of Change in Reference Voltage to the Change in Cathode Voltage	ΔV _{REF} /ΔV _{KA}	I _{KA} = 10mA	ΔV _{KA} = 10V - V _{REF}	-0.5	-1.0	mV/V
			ΔV _{KA} = 36V - 10V	0.1	0.5	
Reference Input Current	I _{REF}	I _{KA} = 10mA, R ₁ = 10kΩ, R ₂ = ∞		1	2	μA
Deviation of Reference Input Current over Full Temperature Range ⁽¹⁾	I _{I(DEV)}	I _{KA} = 10mA, R ₁ = 10kΩ, R ₂ = ∞		0.4	0.8	μA
Minimum Cathode Current for Regulation	I _{MIN}	V _{KA} = V _{REF}		0.4	0.7	mA
Off-State Cathode Current	I _{OFF}	V _{KA} = 36V, V _{REF} = 0		0.1	1	μA
Dynamic Impedance ⁽²⁾	Z _{KA}	V _{KA} = V _{REF} , f ≤ 1kHz, I _{KA} = 1mA to 100mA		0.1	0.5	Ω

NOTES:

1. The deviation parameters V_{I(DEV)} and I_{I(DEV)} are defined as the differences between the maximum and minimum values obtained over the rated temperature range. The average full-range temperature coefficient of the reference input voltage α_{VREF} is defined as:

$$|\alpha_{VREF}| \left(\frac{\text{ppm}}{^\circ\text{C}} \right) = \frac{\left(\frac{V_{I(DEV)}}{V_{REF \text{ at } 25^\circ\text{C}}} \right) \times 10^6}{\Delta T_J}$$

where,

ΔT_J is the rated operating junction temperature range of the device.

α_{VREF} is positive or negative, depending on whether minimum V_{REF} or maximum V_{REF}, respectively, occurs at the lower temperature.

2. The dynamic impedance is defined as:

$$|Z_{KA}| = \frac{\Delta V_{KA}}{\Delta I_{KA}}$$

When the device is operating with two external resistors, the total dynamic impedance of the circuit is given by:

$$|Z'| = \frac{\Delta V}{\Delta I}$$

which is approximately equal to

$$|Z_{KA}| \left(1 + \frac{R_1}{R_2} \right)$$

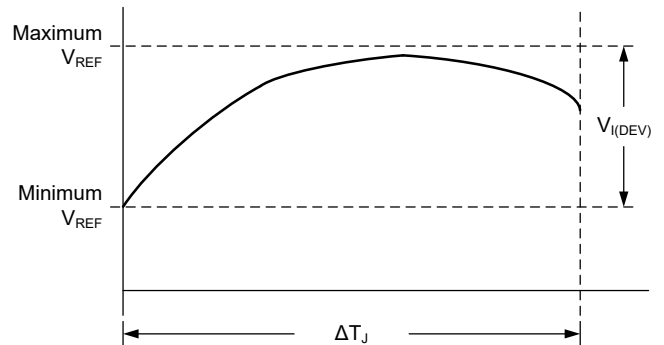

TYPICAL PERFORMANCE CHARACTERISTICS

T_J = +25°C, unless otherwise noted.

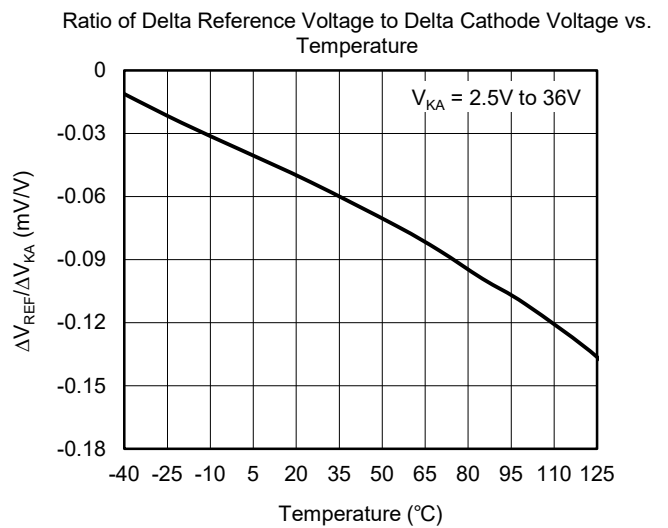
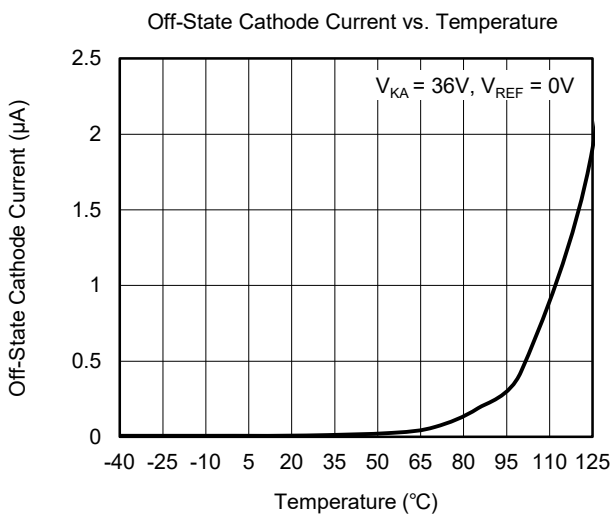
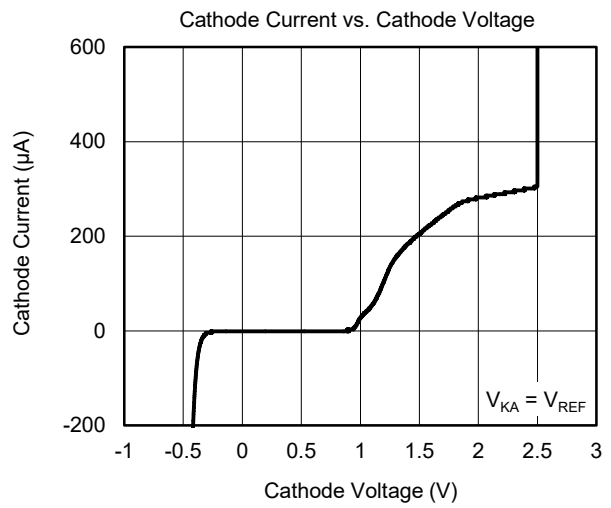
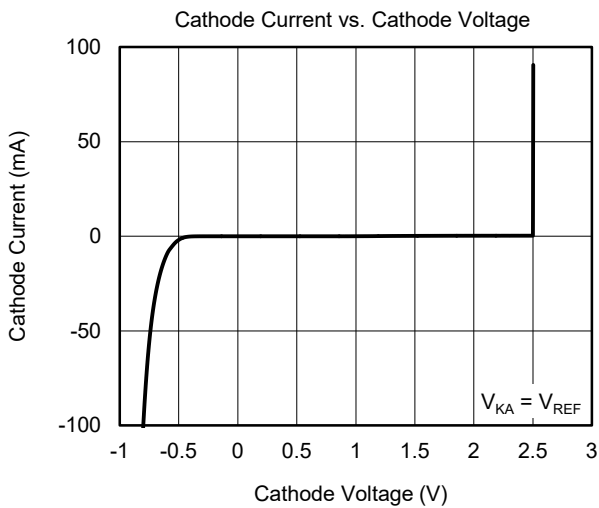
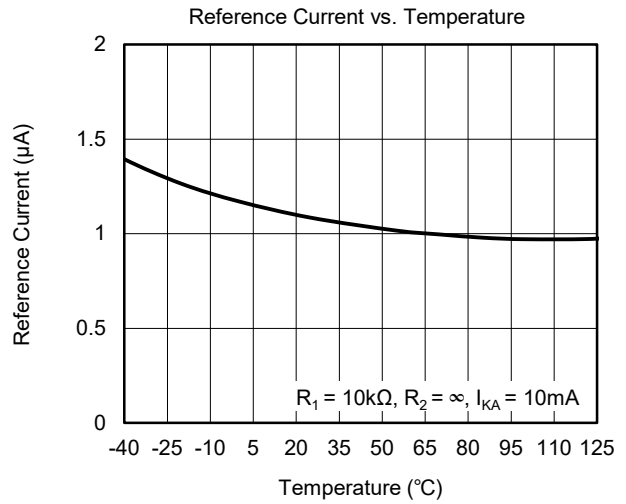
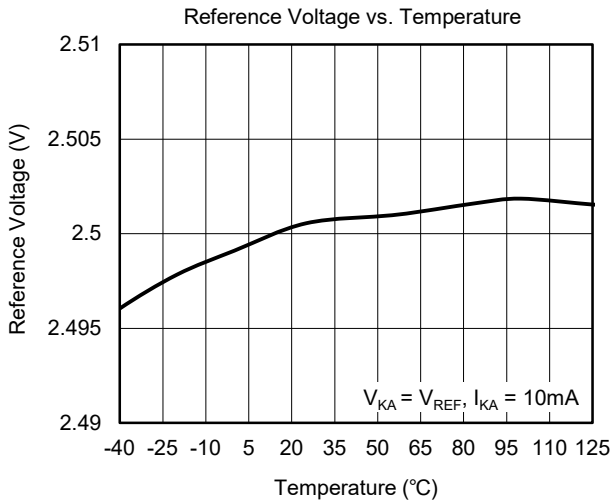

TYPICAL PERFORMANCE CHARACTERISTICS (continued)

T_J = +25°C, unless otherwise noted.

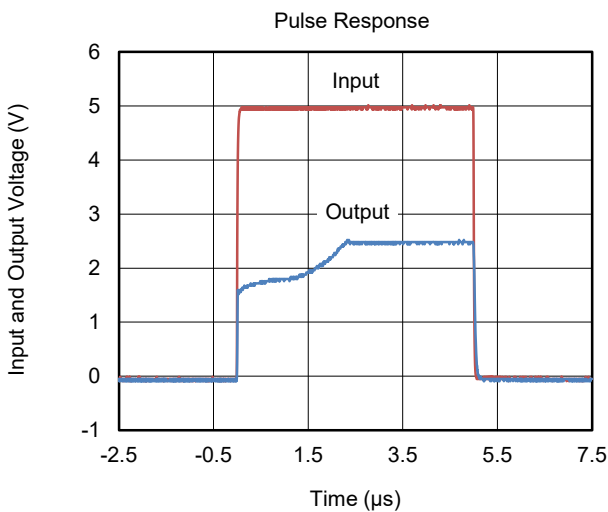
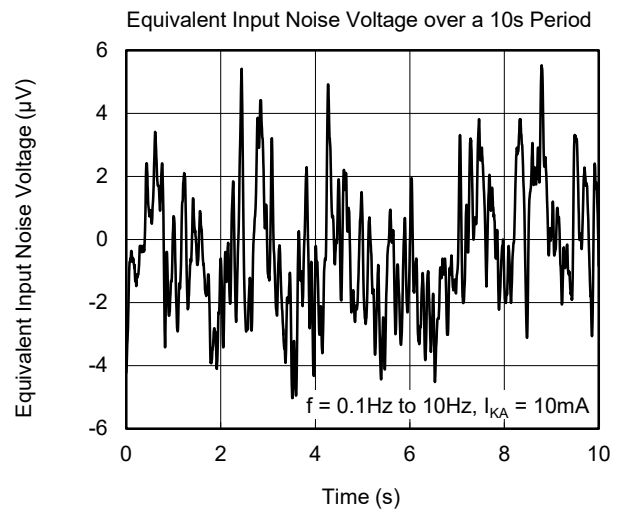
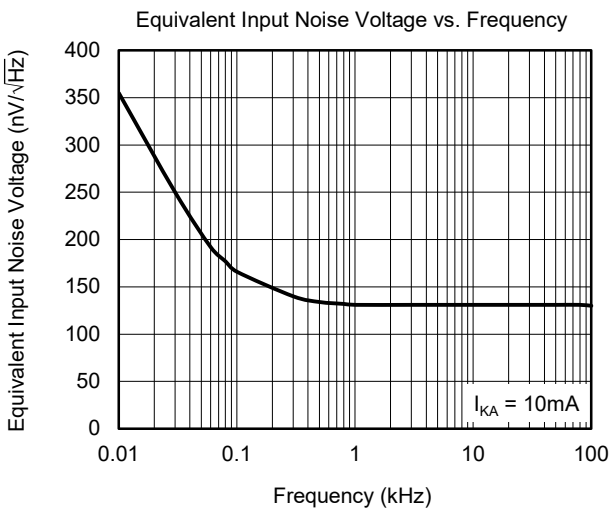
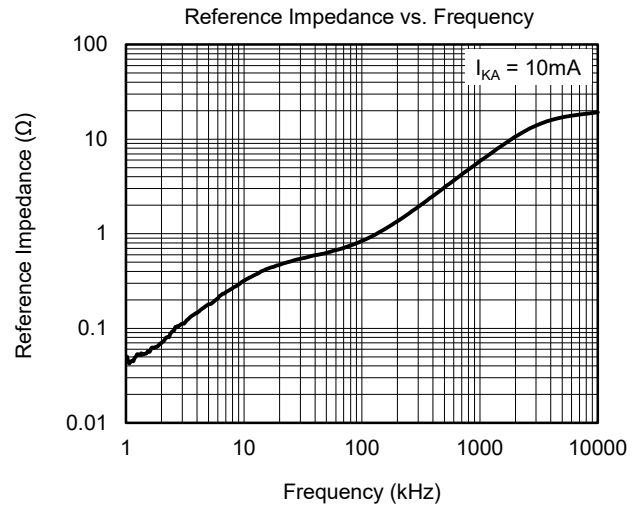
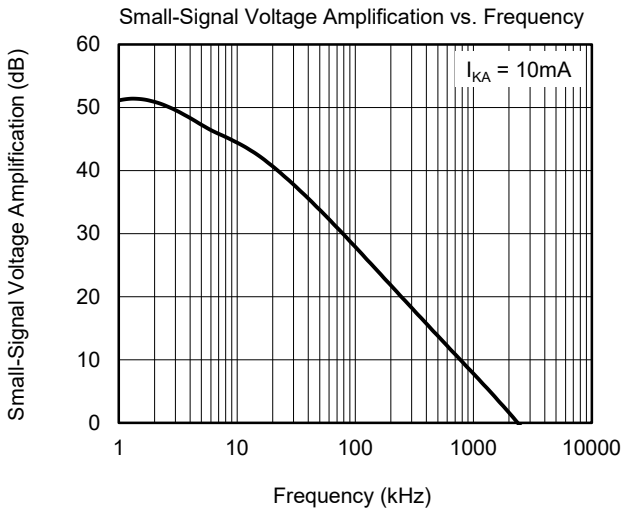

TEST CIRCUITS

Typical Characteristics Measurement Information

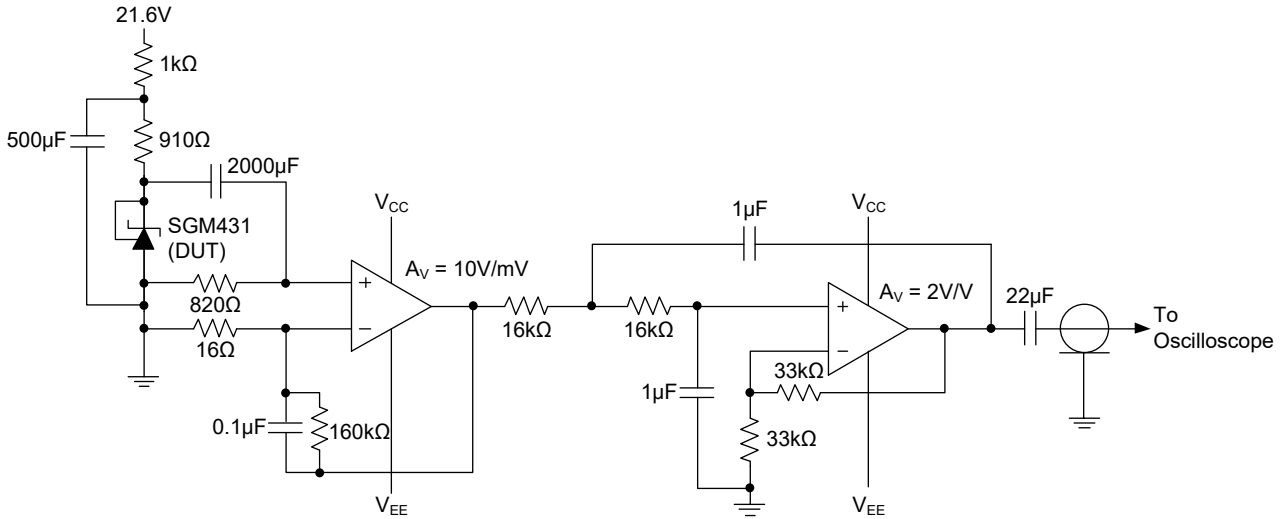

Figure 2. Test Circuit for Equivalent Input Noise Voltage over a 10s Period

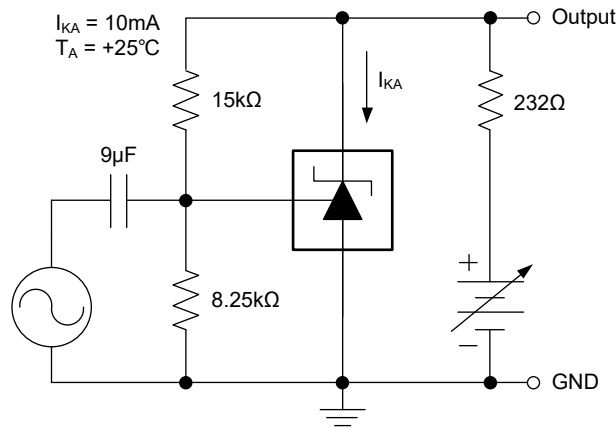

Figure 3. Test Circuit for Voltage Amplification

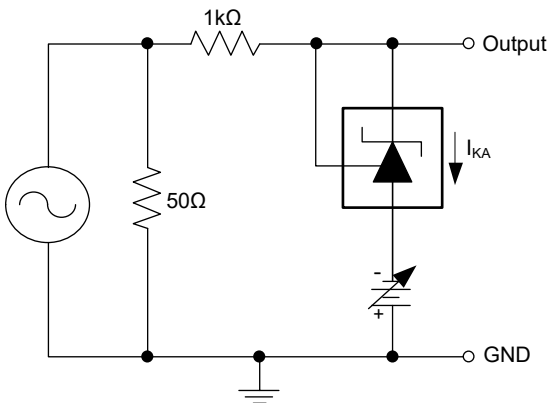

Figure 4. Test Circuit for Reference Impedance

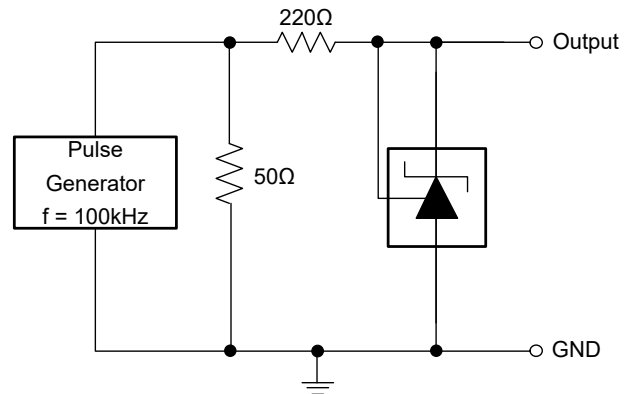

Figure 5. Test Circuit for Pulse Response

TEST CIRCUITS (continued)

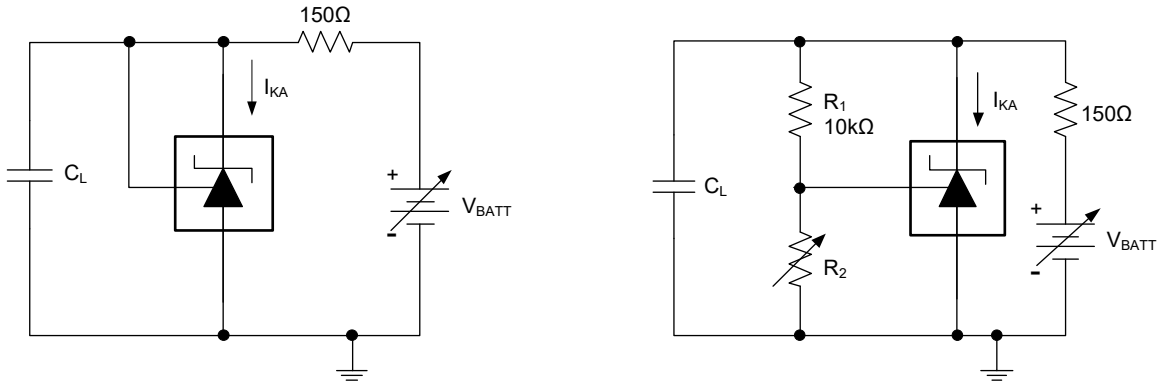

Figure 6. Test Circuits for Stability Boundary Conditions

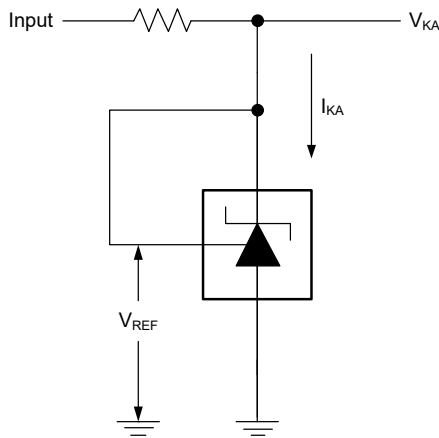
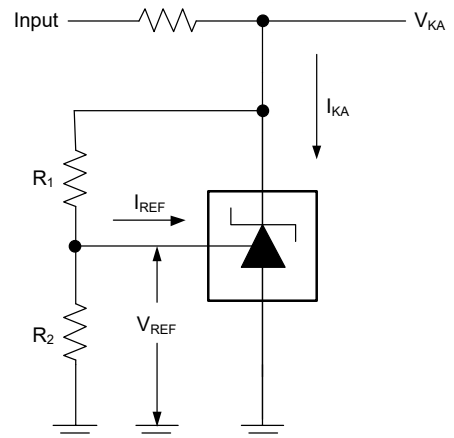

Figure 7. Test Circuit for $V_{KA} = V_{REF}$



$$V_{KA} = V_{REF} \left(1 + \frac{R_1}{R_2} \right) + I_{REF} \times R_1$$

Figure 8. Test Circuit for $V_{KA} > V_{REF}$

FUNCTIONAL BLOCK DIAGRAM

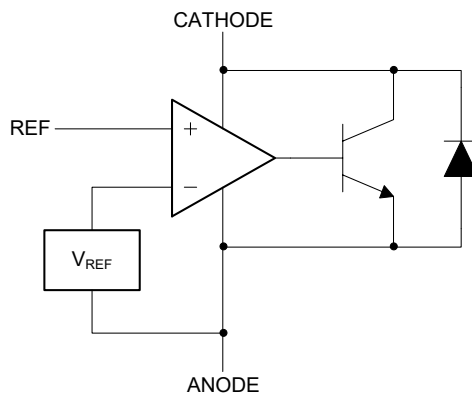

Figure 9. Equivalent Schematic

APPLICATION INFORMATION

SGM431x Used as Comparator with Integrated Reference

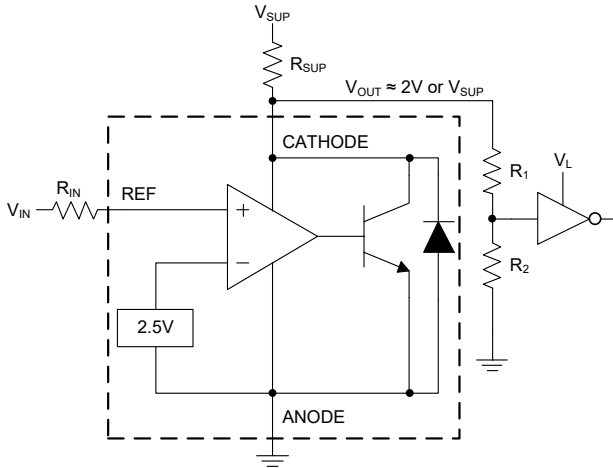

Figure 10. Comparator Application Schematic

SGM431x is always used as a comparator with 2.5V integrated reference in application, for this design, the parameters are listed in Table 1:

Table 1. Design Parameters

Design Parameter	Example Value
Input Voltage Range	0V to 5V
Input Resistance (R_{IN})	10k Ω
Supply Voltage (V_{SUP})	5V to 24V
Supply Resistance (R_{SUP})	1k Ω
Output Voltage Level	~ 2V (Logical "Low") ~ V_{SUP} (Logical "High")

In Figure 10, the SGM431x will behave as a comparator, comparing the REF pin voltage to the internal reference voltage. When provided a proper cathode current (I_{KA}), the SGM431x will have enough open-loop gain to provide a quick response. This can be seen in Figure 11, where the $R_{SUP} = 10k\Omega$ situation responds much slower than $R_{SUP} = 1k\Omega$. With the SGM431x's maximum operating current (I_{MIN}) being 0.7mA, operation below that could result in low gain, leading to a slow response.

Slow or inaccurate responses can also occur when the REF pin is not provided enough overdrive voltage. This is the amount of voltage that is higher than the internal reference. The internal reference voltage will be approximate 2.5V, the more overdrive voltage provided, the faster the SGM431x will respond. For fast response, setting the trip point to > 10% of the internal V_{REF} should suffice.

For minimal voltage drop or difference from V_{IN} to the REF pin, it is recommended to use an input resistor < 10k Ω to provide I_{REF} . The logic output must be readable by the receiving logic device. This is accomplished by knowing the input high and low level threshold voltage levels, typically denoted by V_{IH} and V_{IL} . In Figure 11, the SGM431x's output low level voltage in open-loop/comparator mode is around 2V, which is typically sufficient for 5V supplied logic. However, it would not work for 3.3V or 1.8V supplied logic. In order to accommodate this, a resistive divider can be tied to the output to attenuate the output voltage to a voltage legible to the receiving low voltage logic device. The SGM431x's output high voltage is equal to V_{SUP} due to the SGM431x being open-collector. If V_{SUP} is much higher than the receiving logic's maximum input voltage tolerance, the output must be attenuated to accommodate the outgoing logic's reliability. When using a resistive divider on the output, be sure to make the sum of the resistive divider (R_1 and R_2 in Figure 10) is much greater than R_{SUP} in order to not interfere with the SGM431x's ability to pull close to V_{SUP} when turning off.

The SGM431x requires an input resistance in this application in order to source the reference current (I_{REF}) needed from this device to be in the proper operating regions while turning on. The actual voltage seen at the REF pin will be $V_{REF} = V_{IN} - I_{REF} \times R_{IN}$. Since I_{REF} can be as high as 2 μ A it is recommended to use a resistance small enough that will mitigate the error that I_{REF} creates from V_{IN} .

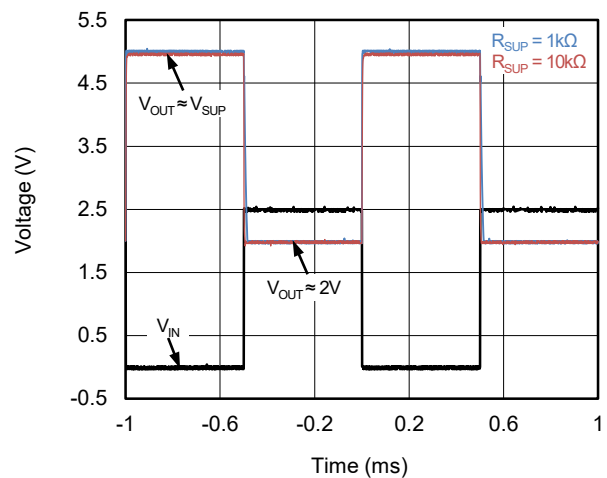

Figure 11. Output Response with Various Cathode Current

APPLICATION INFORMATION (continued)

Shunt Regulator/Reference

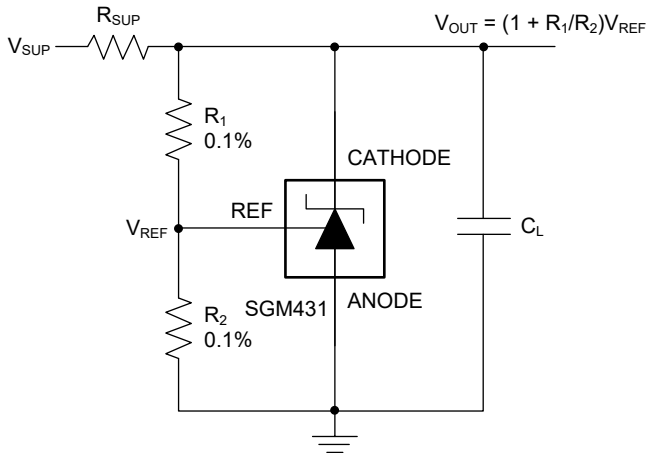

Figure 12. Shunt Regulator Schematic

Design Requirements

For this design example, use the parameters listed in Table 2 as the input parameters.

Table 2. Design Parameters

Design Parameter	Example Value
Supply Voltage	40V
Cathode Current (I_{KA})	5mA
Output Voltage Level	2.5V to 36V
Load Capacitance	100nF
Feedback Resistor Values and Accuracy (R_1 and R_2)	10kΩ (0.1%)

Detailed Design Procedure

When using the SGM431x as a shunt regulator, determine the following:

- ◆ Input Voltage Range
- ◆ Temperature Range
- ◆ Total Accuracy
- ◆ Cathode Current
- ◆ Reference Initial Accuracy
- ◆ Output Capacitance

Programming Output/Cathode Voltage

In order to program the cathode voltage to a regulated voltage a resistive divider must be shunted between the CATHODE and ANODE pins with the mid-point tied to the REF pin. This can be seen in Figure 12, with R_1 and R_2 being the resistive divider. The cathode/output voltage in the shunt regulator configuration can be approximated by the equation shown in Figure 12. The cathode voltage can be more accurately determined by taking into account the reference input current:

$$V_{OUT} = V_{REF} \left(1 + \frac{R_1}{R_2} \right) + I_{REF} \times R_1$$

In order for this equation to be valid, the SGM431x must be fully biased so that it has enough open-loop gain to mitigate any gain error. This can be done by meeting the I_{MIN} specification denoted in Electrical Characteristics.

Total Accuracy

When programming the output above unity gain ($V_{KA} = V_{REF}$), the SGM431x is susceptible to other errors that may effect the overall accuracy beyond V_{REF} . These errors include:

- ◆ R_1 and R_2 accuracies
- ◆ $V_{I(DEV)}$: change in reference voltage over temperature
- ◆ $\Delta V_{REF}/\Delta V_{KA}$: change in reference voltage to the change in cathode voltage
- ◆ $|Z_{KA}|$: dynamic impedance, causing a change in cathode voltage with cathode current

Worst case cathode voltage can be determined by taking all of the variables into account.

APPLICATION INFORMATION (continued)

Stability

For a traditional 431 device, the reference output stability is affected by output decoupling capacitor which must be selected in a limited range in order to keep 431 device stable in applications. However, the SGM431x is different from the others, the SGM431x uses a special design to greatly improve output stability when it drives capacitive load. From the curve of the Cathode Current vs. Load Capacitance in Figure 13, the output of the SGM431x is stable in a wider range of capacitive load. If the SGM431x is used as a linear regulator, a bigger decoupling capacitor can be used to improve regulator's load transient or reduce the noise of power supply. If the SGM431x is used to replace the others, the SGM431x will be stable and there is no need to change the output decoupling capacitor in the original design.

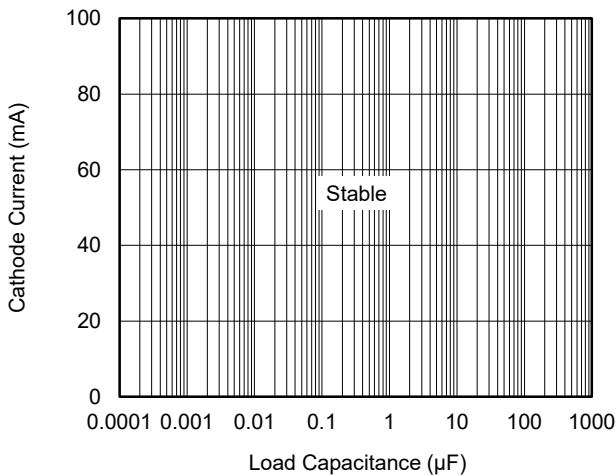

Figure 13. Cathode Current vs. Load Capacitance

Start-Up Time

As shown in Figure 14, the SGM431x has a fast response suitable for many clamp applications.

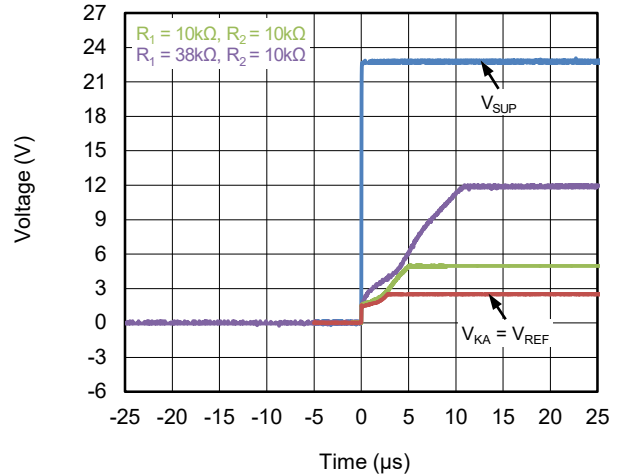

Figure 14. SGM431x Start-Up Response

Power Supply Recommendations

When using the SGM431x as a linear regulator to supply a load, designers will typically use a bypass capacitor on the CATHODE pin. When doing this, the SGM431x remains stable.

In order to not exceed the maximum cathode current, be sure that the supply voltage is current limited. Also, be sure to limit the current being driven into the REF pin, as not to exceed its absolute maximum rating.

For applications shunting high currents, pay attention to the cathode and anode trace lengths, adjusting the width of the traces to have the proper current density.

Layout

Bypass capacitors should be placed as close to the part as possible. Current-carrying traces need to have widths appropriate for the amount of current they are carrying; in the case of the SGM431x, these currents will be low.

REVISION HISTORY

NOTE: Page numbers for previous revisions may differ from page numbers in the current version.

SEPTEMBER 2020 – REV.A.2 to REV.A.3	Page
Updated Application Information section.....	11
AUGUST 2020 – REV.A.1 to REV.A.2	Page
Added Figure 6. Test Circuits for Stability Boundary Conditions.....	9
Updated Application Information section.....	12
JUNE 2020 – REV.A to REV.A.1	Page
Updated Electrical Characteristics section.....	5
Changes from Original (MAY 2020) to REV.A	Page
Changed from product preview to production data.....	All

PACKAGE OUTLINE DIMENSIONS

SOIC-8

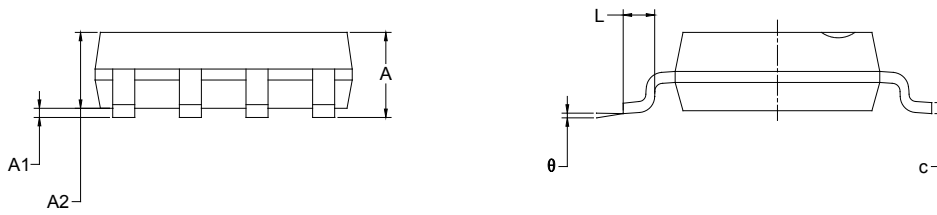
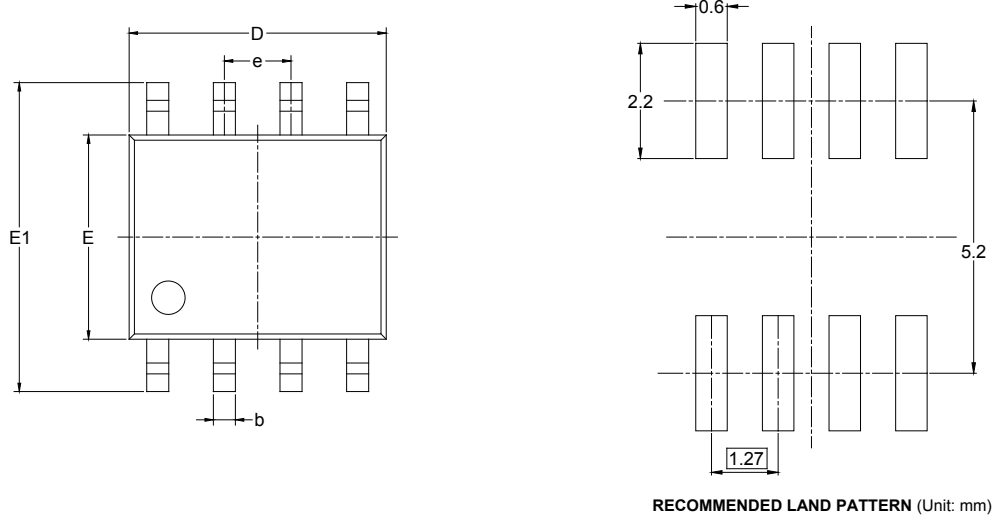

Symbol	Dimensions In Millimeters		Dimensions In Inches	
	MIN	MAX	MIN	MAX
A	1.350	1.750	0.053	0.069
A1	0.100	0.250	0.004	0.010
A2	1.350	1.550	0.053	0.061
b	0.330	0.510	0.013	0.020
c	0.170	0.250	0.006	0.010
D	4.700	5.100	0.185	0.200
E	3.800	4.000	0.150	0.157
E1	5.800	6.200	0.228	0.244
e	1.27 BSC		0.050 BSC	
L	0.400	1.270	0.016	0.050
θ	0°	8°	0°	8°

PACKAGE OUTLINE DIMENSIONS

SOT-23

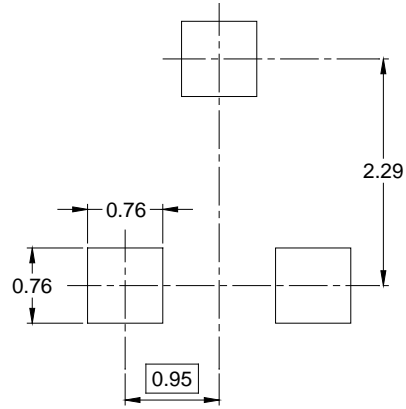
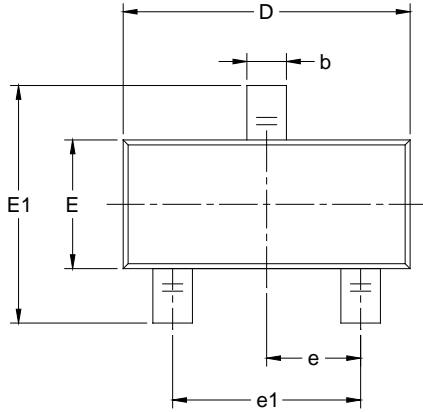

RECOMMENDED LAND PATTERN (Unit: mm)

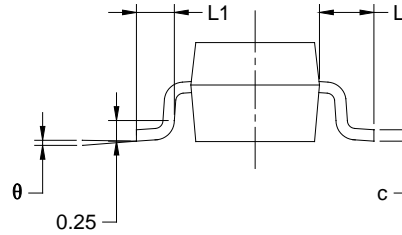
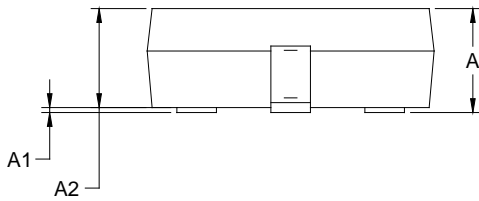

Symbol	Dimensions In Millimeters		Dimensions In Inches	
	MIN	MAX	MIN	MAX
A	0.89	1.12	0.035	0.044
A1	0.01	0.10	0.000	0.004
A2	0.88	1.02	0.035	0.040
b	0.30	0.50	0.012	0.020
c	0.08	0.20	0.003	0.008
D	2.80	3.04	0.110	0.120
E	1.20	1.40	0.047	0.055
E1	2.10	2.64	0.083	0.104
e	0.95 BSC		0.037 BSC	
e1	1.90 BSC		0.075 BSC	
L	0.54 REF		0.021 REF	
L1	0.40	0.60	0.016	0.024
θ	0°	8°	0°	8°

PACKAGE OUTLINE DIMENSIONS

SOT-23-5

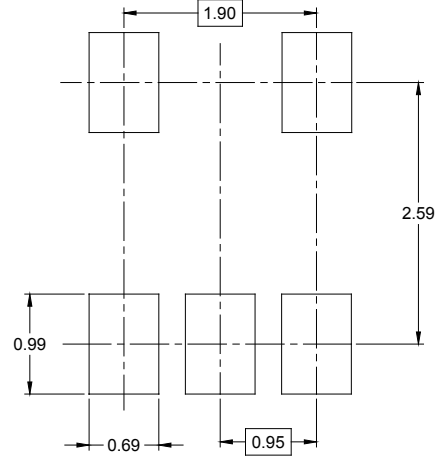
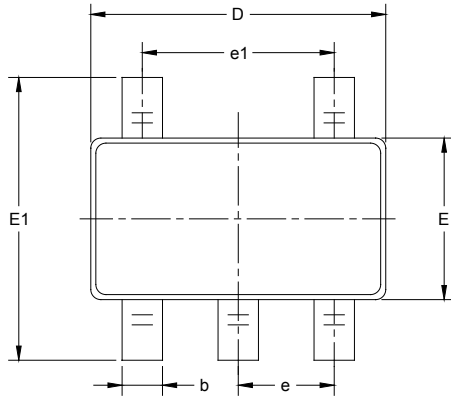

RECOMMENDED LAND PATTERN (Unit: mm)

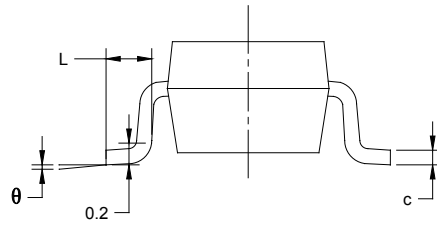
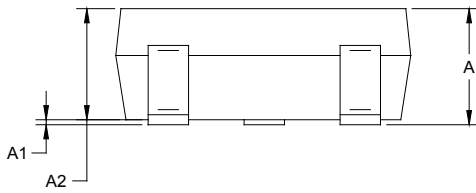

Symbol	Dimensions In Millimeters		Dimensions In Inches	
	MIN	MAX	MIN	MAX
A	1.050	1.250	0.041	0.049
A1	0.000	0.100	0.000	0.004
A2	1.050	1.150	0.041	0.045
b	0.300	0.500	0.012	0.020
c	0.100	0.200	0.004	0.008
D	2.820	3.020	0.111	0.119
E	1.500	1.700	0.059	0.067
E1	2.650	2.950	0.104	0.116
e	0.950 BSC		0.037 BSC	
e1	1.900 BSC		0.075 BSC	
L	0.300	0.600	0.012	0.024
θ	0°	8°	0°	8°

PACKAGE OUTLINE DIMENSIONS

SOT-89-3

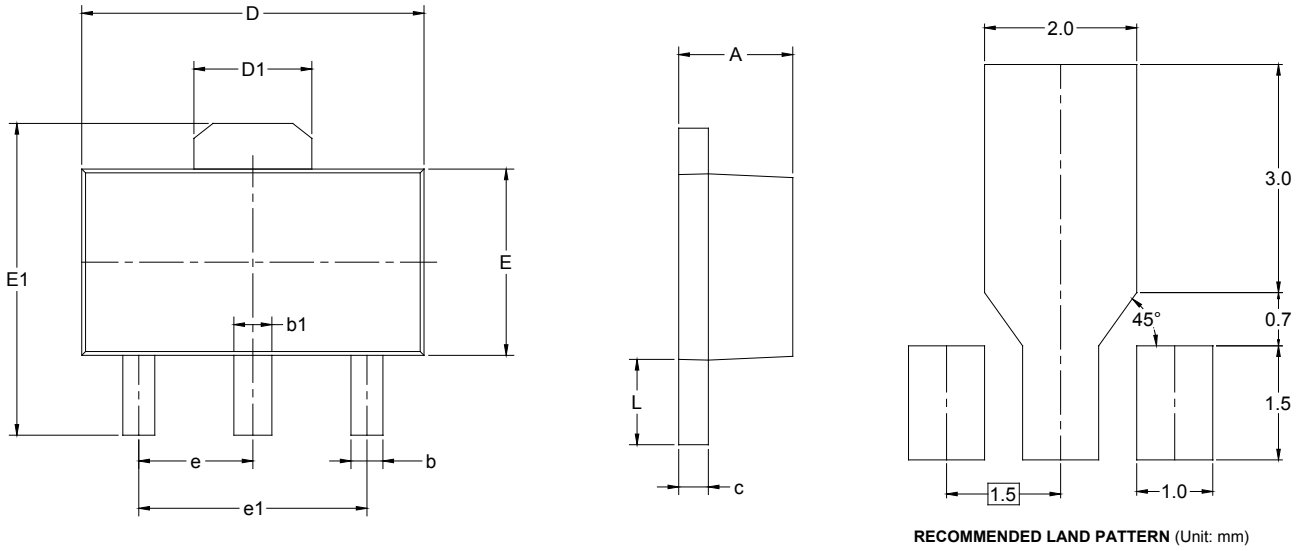

Symbol	Dimensions In Millimeters		Dimensions In Inches	
	MIN	MAX	MIN	MAX
A	1.400	1.600	0.055	0.063
b	0.320	0.520	0.013	0.020
b1	0.400	0.580	0.016	0.023
c	0.350	0.440	0.014	0.017
D	4.400	4.600	0.173	0.181
D1	1.550 REF		0.061 REF	
E	2.300	2.600	0.091	0.102
E1	3.940	4.250	0.155	0.167
e	1.500 TYP		0.060 TYP	
e1	3.000 TYP		0.118 TYP	
L	0.900	1.200	0.035	0.047

PACKAGE OUTLINE DIMENSIONS

SC70-6

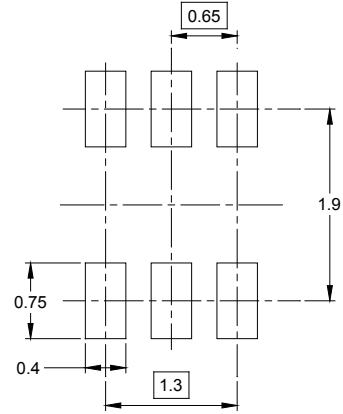
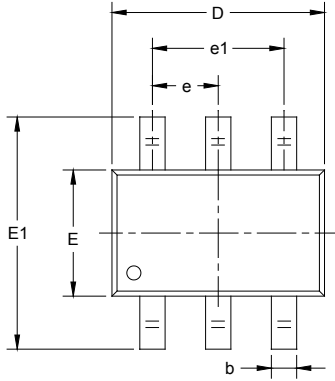

RECOMMENDED LAND PATTERN (Unit: mm)

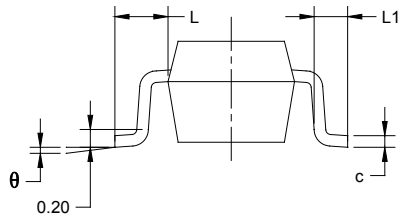
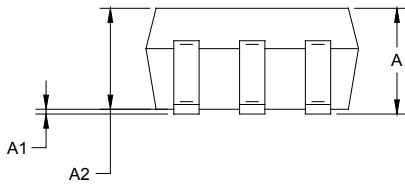

Symbol	Dimensions In Millimeters		Dimensions In Inches	
	MIN	MAX	MIN	MAX
A	0.900	1.100	0.035	0.043
A1	0.000	0.100	0.000	0.004
A2	0.900	1.000	0.035	0.039
b	0.150	0.350	0.006	0.014
c	0.080	0.150	0.003	0.006
D	2.000	2.200	0.079	0.087
E	1.150	1.350	0.045	0.053
E1	2.150	2.450	0.085	0.096
e	0.65 TYP		0.026 TYP	
e1	1.300 BSC		0.051 BSC	
L	0.525 REF		0.021 REF	
L1	0.260	0.460	0.010	0.018
θ	0°	8°	0°	8°

PACKAGE INFORMATION

TAPE AND REEL INFORMATION

REEL DIMENSIONS



TAPE DIMENSIONS



NOTE: The picture is only for reference. Please make the object as the standard.

KEY PARAMETER LIST OF TAPE AND REEL

Package Type	Reel Diameter	Reel Width W1 (mm)	A0 (mm)	B0 (mm)	K0 (mm)	P0 (mm)	P1 (mm)	P2 (mm)	W (mm)	Pin1 Quadrant
SOIC-8	13"	12.4	6.40	5.40	2.10	4.0	8.0	2.0	12.0	Q1
SOT-23	7"	9.5	3.15	2.77	1.22	4.0	4.0	2.0	8.0	Q3
SOT-23-5	7"	9.5	3.20	3.20	1.40	4.0	4.0	2.0	8.0	Q3
SOT-89-3	7"	13.2	4.85	4.45	1.85	4.0	8.0	2.0	12.0	Q3
SC70-6	7"	9.5	2.40	2.50	1.20	4.0	4.0	2.0	8.0	Q3

D20001

PACKAGE INFORMATION

CARTON BOX DIMENSIONS



NOTE: The picture is only for reference. Please make the object as the standard.

KEY PARAMETER LIST OF CARTON BOX

Reel Type	Length (mm)	Width (mm)	Height (mm)	Pizza/Carton
7" (Option)	368	227	224	8
7"	442	410	224	18
13"	386	280	370	5

DD0002