

# TS3702

## Micropower dual CMOS voltage comparators

### Features

- Push-pull CMOS output (no external pull-up resistor required)
- Extremely low supply current: 9 $\mu$ A typ / comparator
- Wide single supply range: 2.7V to 16V or dual supplies ( $\pm 1.35$ V to  $\pm 8$ V)
- Extremely low input bias current: 1pA typ
- Extremely low input offset currents: 1pA typ
- Input common-mode voltage range includes GND
- High input impedance: 10<sup>12</sup> $\Omega$  typ
- Fast response time: 2 $\mu$ s typ for 5mV overdrive
- Pin-to-pin and functionally compatible with bipolar LM393

### Description

The TS3702 is a micropower CMOS dual voltage comparator with extremely low consumption of 9 $\mu$ A typ / comparator (20 times less than bipolar LM393). The push-pull CMOS output stage allows power and space saving by eliminating the external pull-up resistor required by usual open-collector output comparators.

Thus response times remain similar to the LM393.

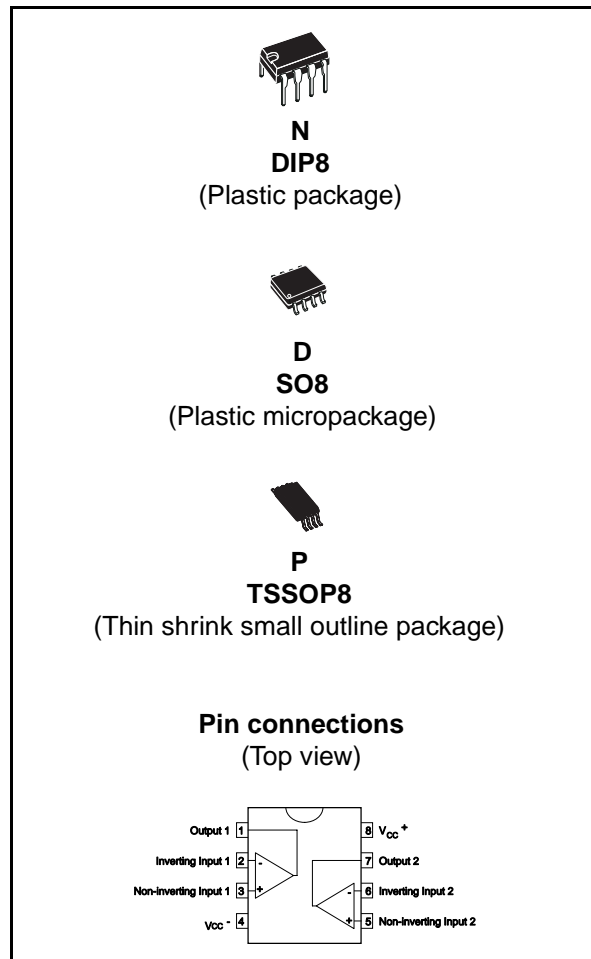

# 1 Schematic diagram

Figure 1. Schematic diagram (for 1/2 TS3702)

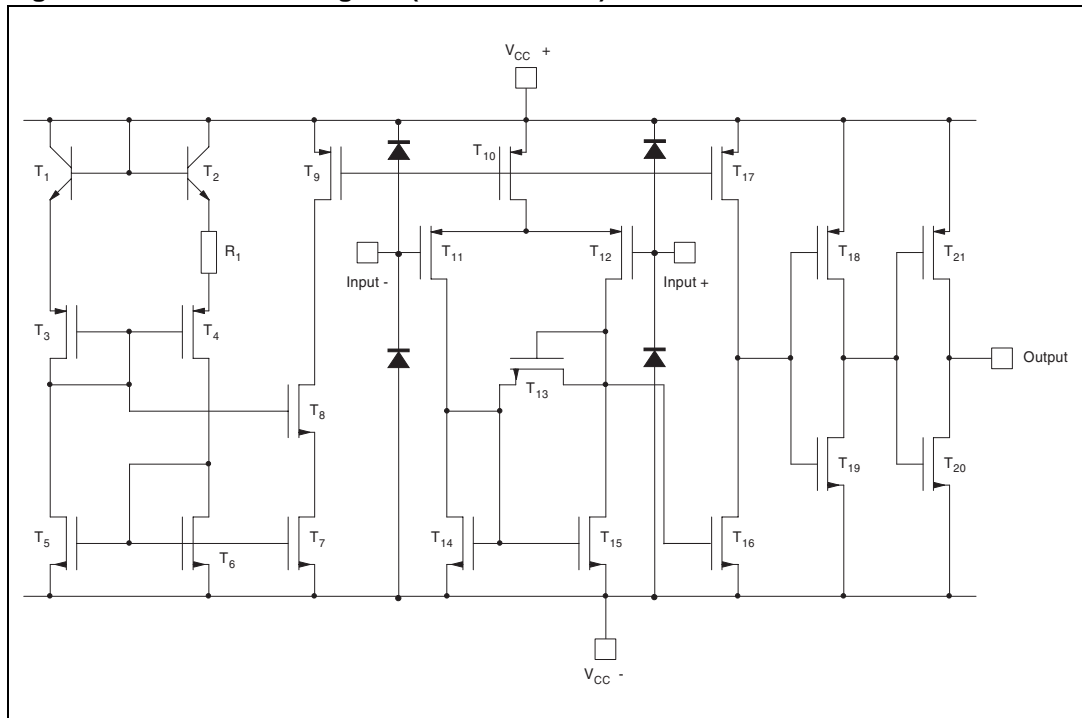

## 2 Absolute maximum ratings and operating conditions

**Table 1. Absolute maximum ratings**

Symbol	Parameter	Value	Unit
$V_{CC}^+$	Supply voltage <sup>(1)</sup>	18	V
$V_{id}$	Differential input voltage <sup>(2)</sup>	±18	V
$V_i$	Input voltage <sup>(3)</sup>	18	V
$V_o$	Output voltage	18	V
$I_o$	Output current	20	mA
$I_F$	Forward current in ESD protection diodes on input <sup>(4)</sup>	50	mA
$P_d$	Power dissipation <sup>(5)</sup>		
	DIP8	1250	mW
	SO8	710	
TSSOP8	625		
$T_{stg}$	Storage temperature range	-65 to +150	°C
ESD	HBM: human body model <sup>(6)</sup>	400	V
	MM: machine model <sup>(7)</sup>	50	V
	CDM: charged device model <sup>(8)</sup>	1.5	kV

- All voltage values, except differential voltage, are with respect to network ground terminal.
- Differential voltages are the non-inverting input terminal with respect to the inverting input terminal.
- The magnitude of the input and the output voltages must never exceed the magnitude of the positive and negative supply voltages.
- Guaranteed by design.
- $P_d$  is calculated with  $T_{amb} = +25^\circ\text{C}$ ,  $T_j = +150^\circ\text{C}$  and  
 $R_{thja} = 100^\circ\text{C/W}$  for DIP8 package  
 $R_{thja} = 175^\circ\text{C/W}$  for SO8 package  
 $R_{thja} = 200^\circ\text{C/W}$  for TSSOP8 package
- Human body model: A 100pF capacitor is charged to the specified voltage, then discharged through a 1.5kΩ resistor between two pins of the device. This is done for all couples of connected pin combinations while the other pins are floating.
- Machine model: A 200pF capacitor is charged to the specified voltage, then discharged directly between two pins of the device with no external series resistor (internal resistor < 5Ω). This is done for all couples of connected pin combinations while the other pins are floating.
- Charged device model: all pins and the package are charged together to the specified voltage and then discharged directly to the ground through only one pin. This is done for all pins.

**Table 2. Operating conditions**

Symbol	Parameter	Value	Unit
$V_{CC}^+$	Supply voltage TS3702C, TS3702I TS3702M	2.7 to 16 4 to 16	V
$V_{icm}$	Common mode input voltage range	0 to $V_{CC}^+ - 1.5$	V
$T_{oper}$	Operating free-air temperature range TS3702C TS3702I TS3702M	0 to +70 -40 to +125 -55 to +125	°C

### 3 Electrical characteristics

**Table 3.**  $V_{CC}^+ = 3V$ ,  $V_{CC}^- = 0V$ ,  $T_{amb} = 25^\circ C$  (unless otherwise specified)

Symbol	Parameter	Min.	Typ.	Max.	Unit
$V_{io}$	Input offset voltage <sup>(1)</sup> $V_{ic} = 1.5V$ $T_{min} \leq T_{amb} \leq T_{max}$			5 6.5	mV
$I_{io}$	Input offset current <sup>(2)</sup> $V_{ic} = 1.5V$ $T_{min} \leq T_{amb} \leq T_{max}$		1	300	pA
$I_{ib}$	Input bias current <sup>(2)</sup> $V_{ic} = 1.5V$ $T_{min} \leq T_{amb} \leq T_{max}$		1	600	pA
$V_{icm}$	Input common mode voltage range $T_{min} \leq T_{amb} \leq T_{max}$	0 0		$V_{CC}^+ - 1.2$ $V_{CC}^+ - 1.5$	V
CMR	Common-mode rejection ratio $V_{ic} = V_{icm\ min}$		80		dB
SVR	Supply voltage rejection ratio $V_{CC}^+ = 3V$ to $5V$		75		dB
$V_{OH}$	High level output voltage $V_{id} = 1V$ , $I_{OH} = -4mA$ $T_{min} \leq T_{amb} \leq T_{max}$	2 1.8	2.4		V
$V_{OL}$	Low level output voltage $V_{id} = -1V$ , $I_{OL} = 4mA$ $T_{min} \leq T_{amb} \leq T_{max}$		300	400 575	mV
$I_{CC}$	Supply current (each comparator) No load - Outputs low $T_{min} \leq T_{amb} \leq T_{max}$		7	20 25	$\mu A$
$t_{PLH}$	Response time low to high $V_{ic} = 0V$ , $f = 10kHz$ , $C_L = 50pF$ , overdrive = 5mV TTL input		1.5 0.7		$\mu s$
$t_{PHL}$	Response time high to low $V_{ic} = 0V$ , $f = 10kHz$ , $C_L = 50pF$ , overdrive = 5mV TTL input		2.2 0.15		$\mu s$

1. The specified offset voltage is the maximum value required to drive the output up to 2.5V or down to 0.3V.
2. Maximum values include unavoidable inaccuracies of the industrial tests.

Table 4.  $V_{CC}^+ = 5V, V_{CC}^- = 0V, T_{amb} = 25^\circ C$  (unless otherwise specified)

Symbol	Parameter	Min.	Typ.	Max.	Unit
$V_{io}$	Input offset voltage $V_{ic} = V_{icm\ min}, V_{CC}^+ = 5V\ to\ 10V$ (1) $T_{min} \leq T_{amb} \leq T_{max}$		1.2	5 6.5	mV
$I_{io}$	Input offset current (2) $V_{ic} = 2.5V$ $T_{min} \leq T_{amb} \leq T_{max}$		1	300	pA
$I_{ib}$	Input bias current (2) $V_{ic} = 2.5V$ $T_{min} \leq T_{amb} \leq T_{max}$		1	600	pA
$V_{icm}$	Input common mode voltage range $T_{min} \leq T_{amb} \leq T_{max}$	0 0		$V_{CC}^+ - 1.2$ $V_{CC}^+ - 1.5$	V
CMR	Common-mode rejection ratio $V_{ic} = V_{icm\ min}$		82		dB
SVR	Supply voltage rejection ratio $V_{CC}^+ = +5V\ to\ +10V$		90		dB
$V_{OH}$	High level output voltage $V_{id} = 1V, I_{OH} = -4mA$ $T_{min} \leq T_{amb} \leq T_{max}$	4.5 4.3	4.7		V
$V_{OL}$	Low level output voltage $V_{id} = -1V, I_{OL} = 4mA$ $T_{min} \leq T_{amb} \leq T_{max}$		200	300 375	mV
$I_{CC}$	Supply current (each comparator) No load - Outputs low $T_{min} \leq T_{amb} \leq T_{max}$		9	20 25	$\mu A$
$t_{PLH}$	Response time low to high $V_{ic} = 0V, f = 10kHz, C_L = 50pF, \text{overdrive} = 5mV$ Overdrive = 10mV Overdrive = 20mV Overdrive = 40mV TTL input		1.5 1.1 0.9 0.7 0.6		$\mu s$
$t_{PHL}$	Response time high to low $V_{ic} = 0V, f = 10kHz, C_L = 50pF, \text{overdrive} = 5mV$ Overdrive = 10mV Overdrive = 20mV Overdrive = 40mV TTL input		2.2 1.6 1.1 0.75 0.17		$\mu s$
$t_f$	Fall time $f = 10kHz, C_L = 50pF, \text{overdrive} = 50mV$		30		ns

1. The specified offset voltage is the maximum value required to drive the output up to 4.5V or down to 0.3V.
2. Maximum values include unavoidable inaccuracies of the industrial tests.

## 4 Package information

In order to meet environmental requirements, STMicroelectronics offers these devices in ECOPACK® packages. These packages have a Lead-free second level interconnect. The category of second level interconnect is marked on the package and on the inner box label, in compliance with JEDEC Standard JESD97. The maximum ratings related to soldering conditions are also marked on the inner box label. ECOPACK is an STMicroelectronics trademark. ECOPACK specifications are available at:

### 4.1 DIP8 package mechanical data

Ref.	Dimensions					
	Millimeters			Inches		
	Min.	Typ.	Max.	Min.	Typ.	Max.
A		3.3			0.130	
a1	0.7			0.028		
B	1.39		1.65	0.055		0.065
B1	0.91		1.04	0.036		0.041
b		0.5			0.020	
b1	0.38		0.5	0.015		0.020
D			9.8			0.386
E		8.8			0.346	
e		2.54			0.100	
e3		7.62			0.300	
e4		7.62			0.300	
F			7.1			0.280
I			4.8			0.189
L		3.3			0.130	
Z	0.44		1.6	0.017		0.063

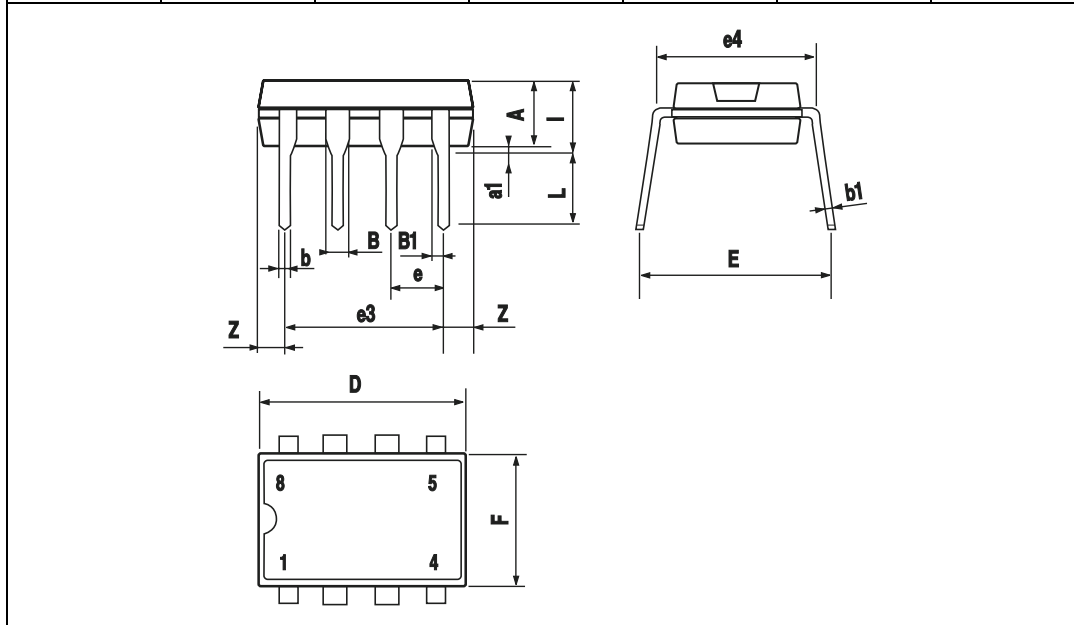

### 4.2 SO8 package mechanical data

Ref.	Dimensions					
	Millimeters			Inches		
	Min.	Typ.	Max.	Min.	Typ.	Max.
A	1.35		1.75	0.053		0.069
A1	0.10		0.25	0.04		0.010
A2	1.10		1.65	0.043		0.065
B	0.33		0.51	0.013		0.020
C	0.19		0.25	0.007		0.010
D	4.80		5.00	0.189		0.197
E	3.80		4.00	0.150		0.157
e		1.27			0.050	
H	5.80		6.20	0.228		0.244
h	0.25		0.50	0.010		0.020
L	0.40		1.27	0.016		0.050
k	8° (max.)					
ddd			0.1			0.04

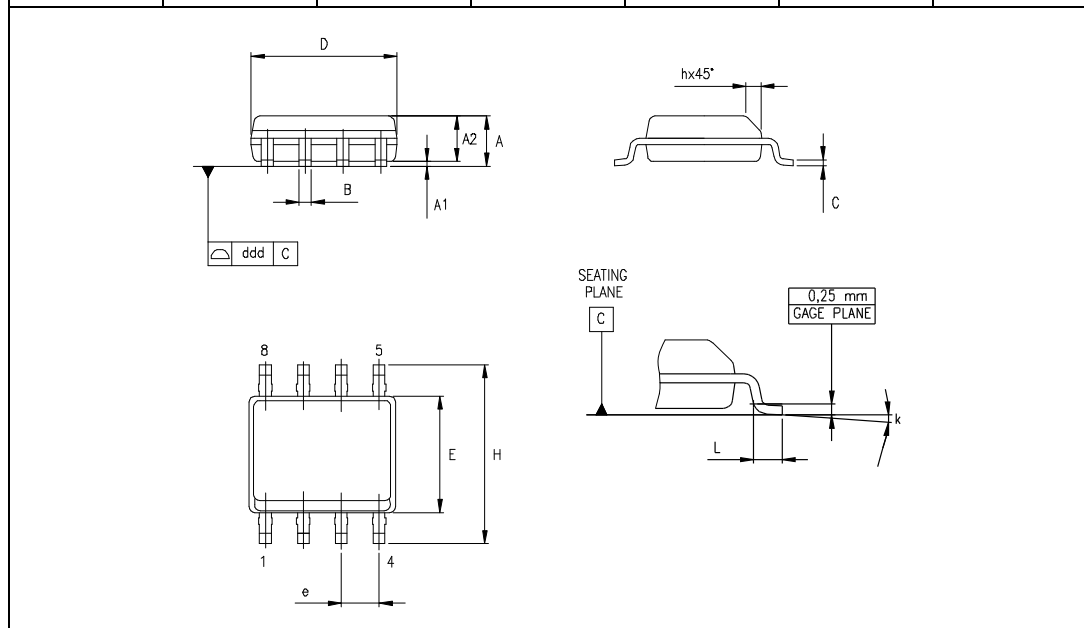



### 4.3 TSSOP8 package mechanical data

Ref.	Dimensions					
	Millimeters			Inches		
	Min.	Typ.	Max.	Min.	Typ.	Max.
A			1.2			0.047
A1	0.05		0.15	0.002		0.006
A2	0.80	1.00	1.05	0.031	0.039	0.041
b	0.19		0.30	0.007		0.012
c	0.09		0.20	0.004		0.008
D	2.90	3.00	3.10	0.114	0.118	0.122
E	6.20	6.40	6.60	0.244	0.252	0.260
E1	4.30	4.40	4.50	0.169	0.173	0.177
e		0.65			0.0256	
K	0°		8°	0°		8°
L	0.45	0.60	0.75	0.018	0.024	0.030
L1		1			0.039	

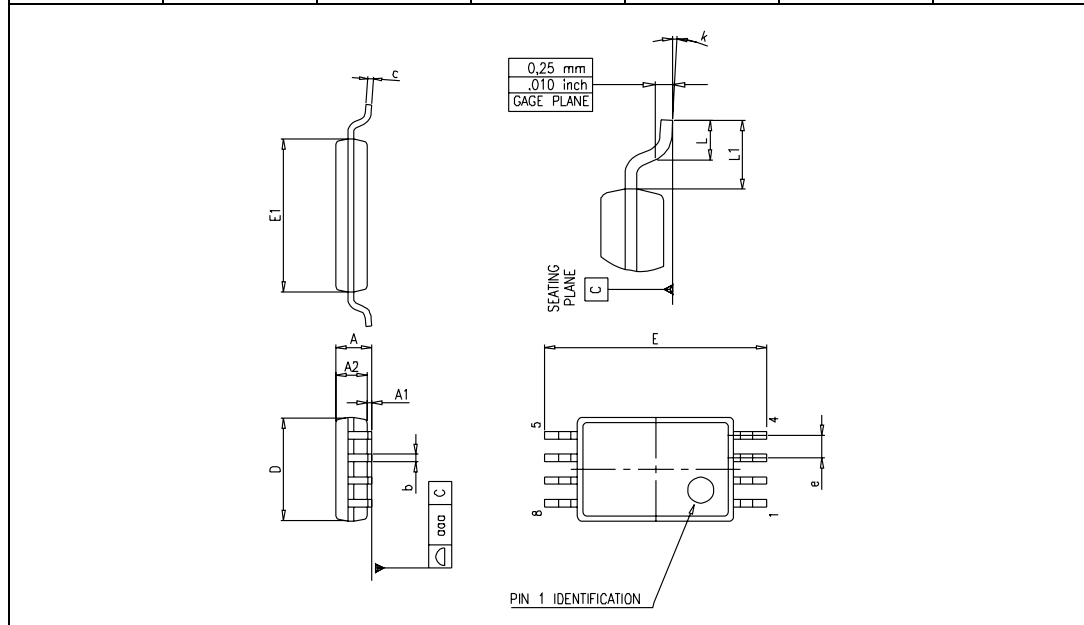

## 5 Ordering information

Table 5. Order codes

Part number	Temperature range	Package	Packaging	Marking
TS3702CN	0°C, +70°C	DIP8	Tube	TS3702CN
TS3702CD/CDT		SO8	Tube or tape & reel	3702C
TS3702IN	-40°C, +125°C	DIP8	Tube	TS3702IN
TS3702ID/IDT		SO8	Tube or tape & reel	3702I
TS3702IPT		TSSOP8	Tape & reel	3702I
TS3702MN	-55°C, +125°C	DIP8	Tube	TS3702MN
TS3702MD/MDT		SO8	Tube or tape & reel	3702M
TS3702MPT		TSSOP8	Tape & reel	3702M

## 6 Revision history

Date	Revision	Changes
2-Jan-2003	1	First release.
2-May-2005	2	PPAP references inserted in the datasheet, see <a href="#">Section 5: Ordering information on page 10</a> .
26-Feb-2007	3	PPAP references removed. ESD data added to <a href="#">Table 1 on page 3</a> . Order codes added to <a href="#">Table 5 on page 10</a> .