

# NCV2393, TS393

## Micropower Dual CMOS Voltage Comparator

The NCV2393 and TS393 are micropower CMOS dual voltage comparators. They feature extremely low consumption of 6  $\mu\text{A}$  typical per comparator and operate over a wide temperature range of  $T_A = -40$  to  $125^\circ\text{C}$ . The NCV2393 and TS393 are available in an SOIC-8 package.

### Features

- Extremely Low Supply Current: 6  $\mu\text{A}$  Typical Per Channel
- Wide Supply Range: 2.7 to 16 V
- Extremely Low Input Bias Current: 1 pA Typical
- Extremely Low Input Offset Current: 1 pA Typical
- Input Common Mode Range Includes  $V_{SS}$
- High Input Impedance:  $10^{12} \Omega$
- Pin-to-Pin Compatibility with Dual Bipolar LM393
- NCV Prefix for Automotive and Other Applications Requiring Unique Site and Control Change Requirements; AEC-Q100 Qualified and PPAP Capable
- These Devices are Pb-Free, Halogen Free/BFR Free and are RoHS Compliant

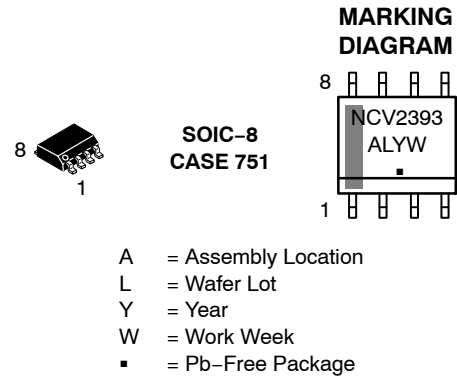

### PIN CONNECTIONS

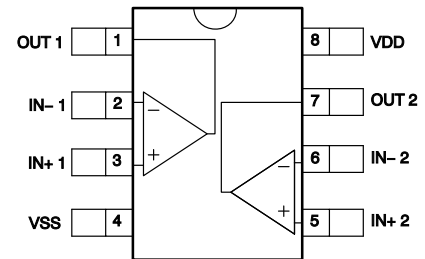

### ORDERING INFORMATION

Device	Package	Shipping <sup>†</sup>
NCV2393DR2G	SOIC-8 (Pb-Free)	2500 / Tape & Reel
TS393DR2G	SOIC-8 (Pb-Free)	2500 / Tape & Reel

<sup>†</sup>For information on tape and reel specifications, including part orientation and tape sizes, please refer to our Tape and Reel Packaging Specifications Brochure, BRD8011/D.

# NCV2393, TS393

## PIN DESCRIPTION

Pin	Name	Type	Description
1	OUT 1	Output	Output of comparator 1. The open-drain output requires an external pull-up resistor.
2	IN- 1	Input	Inverting input of comparator 1
3	IN+ 1	Input	Non-inverting input of comparator 1
4	VSS	Power	Negative supply
5	IN+ 2	Input	Non-inverting input of comparator 2
6	IN- 2	Input	Inverting input of comparator 2
7	OUT 2	Output	Output of comparator 2. The open-drain output requires an external pull-up resistor.
8	VDD	Power	Positive supply

## ABSOLUTE MAXIMUM RATINGS (Note 1)

Over operating free-air temperature, unless otherwise stated

Parameter	Limit	Unit
Supply Voltage, $V_S$ ( $V_{DD}-V_{SS}$ )	18	V

## INPUT AND OUTPUT PINS

Input Voltage (Note 2)	18	V
Input Differential Voltage, $V_{ID}$ (Note 3)	$\pm 18$	V
Input Current (through ESD protection diodes)	50	mA
Output Voltage	18	V
Output Current	20	mA

## TEMPERATURE

Storage Temperature	-65 to +150	°C
Junction Temperature	150	°C

## ESD RATINGS

Human Body Model	1500	V
Machine Model	50	V

## LATCH-UP RATINGS

Latch-up Current	100	mA
------------------	-----	----

Stresses exceeding those listed in the Maximum Ratings table may damage the device. If any of these limits are exceeded, device functionality should not be assumed, damage may occur and reliability may be affected.

- Stresses beyond the absolute maximum ratings can lead to reduced reliability and damage.
- Excursions of input voltages may exceed the power supply level. As long as the common mode voltage [ $V_{CM} = (V_{IN+} + V_{IN-})/2$ ] remains within the specified range, the comparator will provide a stable output state. However, the maximum current through the ESD diodes of the input stage must strictly be observed.
- Input differential voltage is the non-inverting input terminal with respect to the inverting input terminal. To prevent damage to the gates, each comparator includes back-to-back zener diodes between input terminals. When differential voltage exceeds 6.2 V, the diodes turn on. Input resistors of 1 k $\Omega$  have been integrated to limit the current in this event.
- This device series incorporates ESD protection and is tested by the following methods:  
ESD Human Body Model tested per AEC-Q100-002 (JEDEC standard: JESD22-A114)  
ESD Machine Model tested per AEC-Q100-003 (JEDEC standard: JESD22-A115)  
Latch-up Current tested per JEDEC standard: JESD78.

## THERMAL INFORMATION (Note 5)

Thermal Metric	Symbol	Value	Unit
Junction-to-Ambient (Note 6)	$\theta_{JA}$	190	°C/W
Junction-to-Case Top	$\Psi_{JT}$	107	°C/W

- Short-circuits can cause excessive heating and destructive dissipation. Values are typical.
- Multilayer board, 1 oz. copper, 400 mm<sup>2</sup> copper area, both junctions heated equally

# NCV2393, TS393

## OPERATING CONDITIONS

Parameter	Symbol	Limit	Unit
Supply Voltage ( $V_{DD} - V_{SS}$ )	$V_S$	+2.7 to +16	V
Operating Free Air Temperature Range	$T_A$	-40 to +125	°C

Functional operation above the stresses listed in the Recommended Operating Ranges is not implied. Extended exposure to stresses beyond the Recommended Operating Ranges limits may affect device reliability.

## ELECTRICAL CHARACTERISTICS: $V_S = +3\text{ V}$

(**Boldface** limits apply over the specified temperature range,  $T_A = -40^\circ\text{C}$  to  $+125^\circ\text{C}$ , guaranteed by characterization and/or design.)

Parameter	Symbol	Conditions	Min	Typ	Max	Unit
-----------	--------	------------	-----	-----	-----	------

### INPUT CHARACTERISTICS

Offset Voltage	$V_{OS}$	$V_{CM} = \text{mid-supply}$		1.4	13	mV
					<b>14</b>	mV
Input Bias Current (Note 7)	$I_{IB}$	$V_{CM} = \text{mid-supply}$		1		pA
					<b>600</b>	pA
Input Offset Current (Note 7)	$I_{OS}$	$V_{CM} = \text{mid-supply}$		1		pA
					<b>300</b>	pA
Input Common Mode Range	$V_{CM}$		$V_{SS}$		$V_{DD} - 1.5$	V
			<b><math>V_{SS}</math></b>		<b><math>V_{DD} - 2</math></b>	V
Common Mode Rejection Ratio	CMRR	$V_{CM} = V_{SS}$ to $V_{CM} = V_{DD} - 1.5\text{ V}$		70		dB

### OUTPUT CHARACTERISTICS

Output Voltage Low	$V_{OL}$	$V_{ID} = -1\text{ V}$ , $I_{OL} = +6\text{ mA}$		$V_{SS} + 300$	$V_{SS} + 450$	mV
					<b><math>V_{SS} + 700</math></b>	mV
Output Current High	$I_{OH}$	$V_{ID} = +1\text{ V}$ , $V_{OH} = +3\text{ V}$		2	40	nA
					<b>1000</b>	nA

### DYNAMIC PERFORMANCE

Propagation Delay Low to High	$t_{PLH}$	$V_{CM} = \text{mid-supply}$ , $f = 10\text{ kHz}$ , $R_{PU} = 5.1\text{ k}\Omega$ , $C_L = 50\text{ pF}$	5 mV overdrive	2.1		$\mu\text{s}$
			TTL input	0.6		$\mu\text{s}$
Propagation Delay High to Low	$t_{PHL}$	$V_{CM} = \text{mid-supply}$ , $f = 10\text{ kHz}$ , $R_{PU} = 5.1\text{ k}\Omega$ , $C_L = 50\text{ pF}$	5 mV overdrive	3.9		$\mu\text{s}$
			TTL input	0.2		$\mu\text{s}$

### POWER SUPPLY

Power Supply Rejection Ratio	PSRR	$V_S = +3\text{ V}$ to $+5\text{ V}$		70		dB
Quiescent Current	$I_{DD}$	Per channel, no load, output = LOW		6	15	$\mu\text{A}$
					<b>20</b>	$\mu\text{A}$

Product parametric performance is indicated in the Electrical Characteristics for the listed test conditions, unless otherwise noted. Product performance may not be indicated by the Electrical Characteristics if operated under different conditions.

7. Guaranteed by characterization and/or design.

# NCV2393, TS393

**ELECTRICAL CHARACTERISTICS:**  $V_S = +5\text{ V}$ , unless otherwise noted

(**Boldface** limits apply over the specified temperature range,  $T_A = -40^\circ\text{C}$  to  $+125^\circ\text{C}$ , guaranteed by characterization and/or design.)

Parameter	Symbol	Conditions	Min	Typ	Max	Unit
-----------	--------	------------	-----	-----	-----	------

## INPUT CHARACTERISTICS

Offset Voltage	$V_{OS}$	$V_{CM} = \text{mid-supply V, } V_S = 5\text{ V to } 10\text{ V}$		1.4	13	mV
					<b>14</b>	mV
Input Bias Current (Note 8)	$I_{IB}$	$V_{CM} = \text{mid-supply}$		1		pA
					<b>600</b>	pA
Input Offset Current (Note 8)	$I_{OS}$	$V_{CM} = \text{mid-supply}$		1		pA
					<b>300</b>	pA
Input Common Mode Range	$V_{CM}$		$V_{SS}$		$V_{DD} - 1.5$	V
			$V_{SS}$		$V_{DD} - 2$	V
Common Mode Rejection Ratio	CMRR	$V_{CM} = V_{SS}$ to $V_{CM} = V_{DD} - 1.5\text{ V}$		71		dB

## OUTPUT CHARACTERISTICS

Output Voltage Low	$V_{OL}$	$V_{ID} = -1\text{ V, } I_{OL} = +6\text{ mA}$		$V_{SS} + 260$	$V_{SS} + 350$	mV
					<b><math>V_{SS} + 550</math></b>	mV
Output Current High	$I_{OH}$	$V_{ID} = +1\text{ V, } V_{OH} = +5\text{ V}$		2	40	nA
					<b>1000</b>	nA

## DYNAMIC PERFORMANCE

Fall Time	$t_{FALL}$	50 mV overdrive, $f = 10\text{ kHz, } R_{PU} = 5.1\text{ k}\Omega,$ $C_L = 50\text{ pF}$		25		ns
Propagation Delay Low to High	$t_{PLH}$	$V_{CM} = \text{mid-supply,}$ $f = 10\text{ kHz, } R_{PU} = 5.1\text{ k}\Omega,$ $C_L = 50\text{ pF}$	5 mV overdrive	2.1		$\mu\text{s}$
			10 mV overdrive	1.2		$\mu\text{s}$
			20 mV overdrive	0.8		$\mu\text{s}$
			40 mV overdrive	0.5		$\mu\text{s}$
			TTL input	0.6		$\mu\text{s}$
Propagation Delay High to Low	$t_{PHL}$	$V_{CM} = \text{mid-supply,}$ $f = 10\text{ kHz, } R_{PU} = 5.1\text{ k}\Omega,$ $C_L = 50\text{ pF}$	5 mV overdrive	5.8		$\mu\text{s}$
			10 mV overdrive	3.2		$\mu\text{s}$
			20 mV overdrive	1.7		$\mu\text{s}$
			40 mV overdrive	1.0		$\mu\text{s}$
			TTL input	0.3		$\mu\text{s}$

## POWER SUPPLY

Power Supply Rejection Ratio	PSRR	$V_S = +5\text{ V to } +10\text{ V}$		80		dB
Quiescent Current	$I_{DD}$	Per channel, no load, output = LOW		6	15	$\mu\text{A}$
					<b>20</b>	$\mu\text{A}$

Product parametric performance is indicated in the Electrical Characteristics for the listed test conditions, unless otherwise noted. Product performance may not be indicated by the Electrical Characteristics if operated under different conditions.

8. Guaranteed by characterization and/or design

# NCV2393, TS393

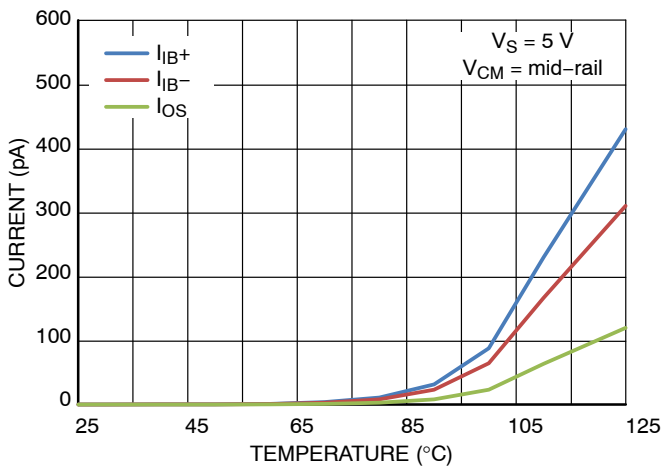

Figure 1.  $I_{IB}$  and  $I_{OS}$  vs. Temperature

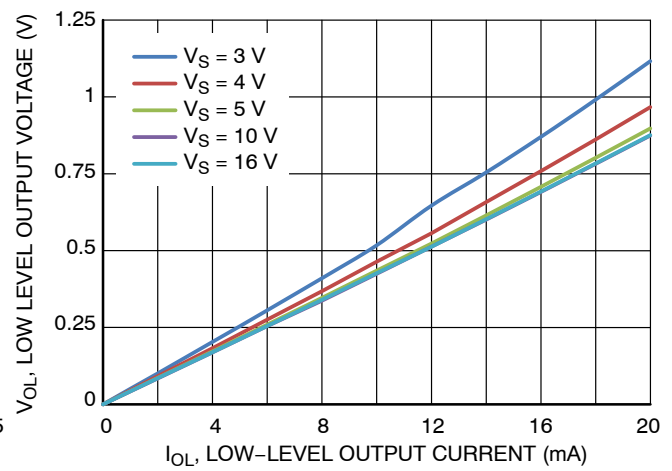

Figure 2.  $V_{OL}$  vs.  $I_{OL}$

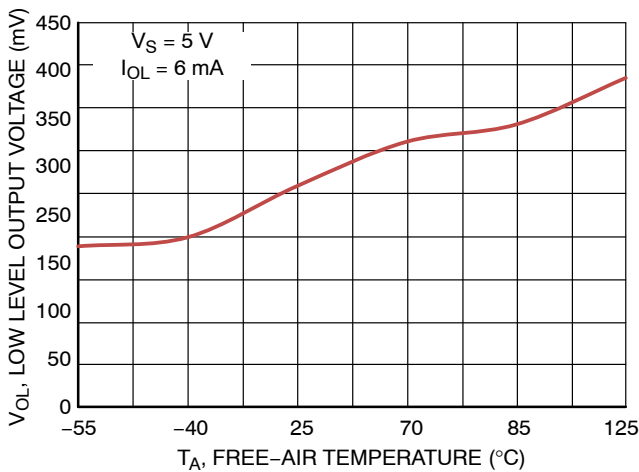

Figure 3.  $V_{OL}$  vs. Temperature

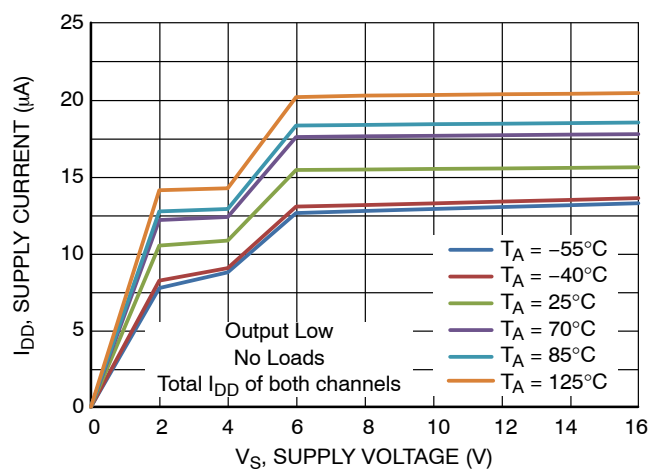

Figure 4.  $I_{DD}$  vs.  $V_S$

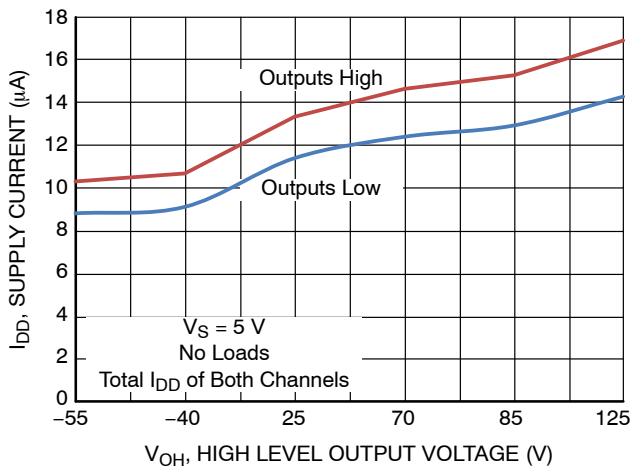

Figure 5.  $I_{DD}$  vs. Temperature

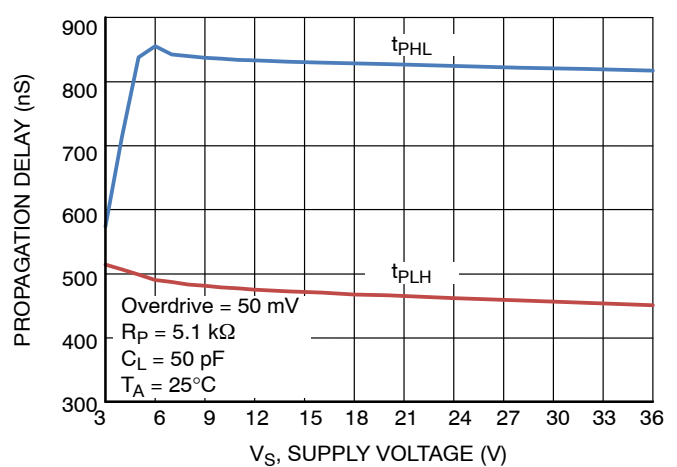

Figure 6. Propagation Delay vs.  $V_S$

# NCV2393, TS393

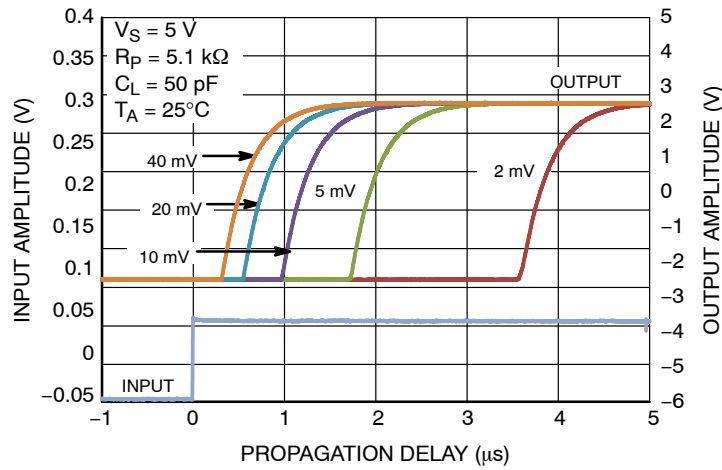

Figure 7.  $t_{pLH}$  vs. Overdrive

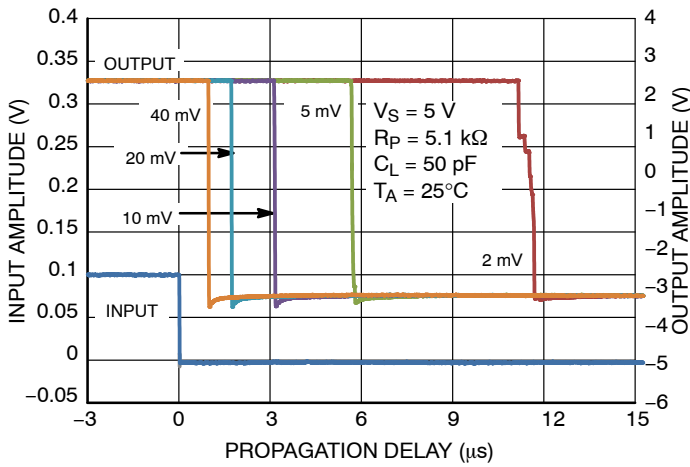

Figure 8.  $t_{pHL}$  vs. Overdrive

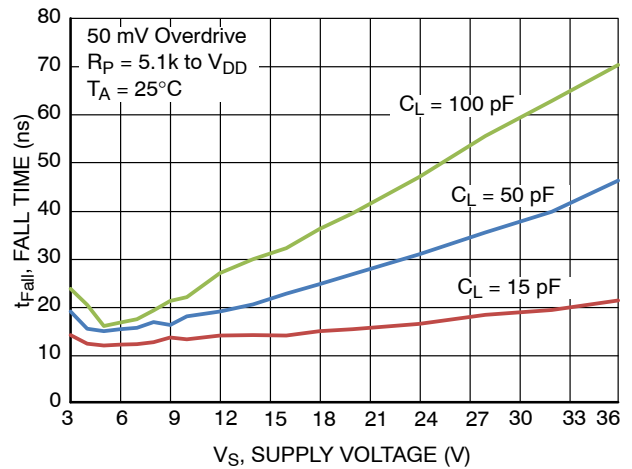

Figure 9. Fall Time vs.  $V_S$

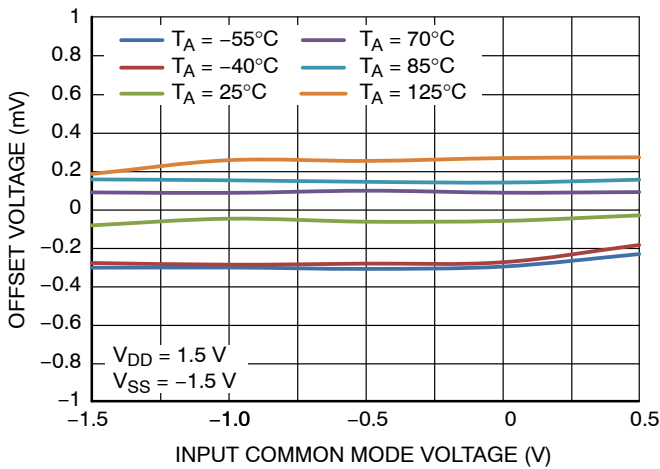

Figure 10.  $V_{OS}$  vs.  $V_{CM}$  ( $V_S = 3\text{ V}$ )

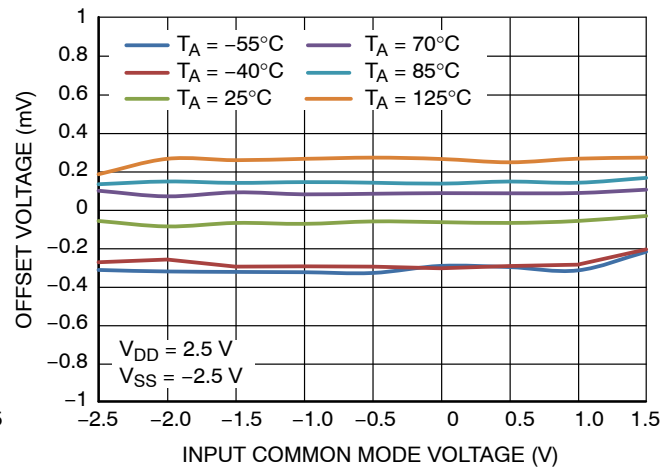
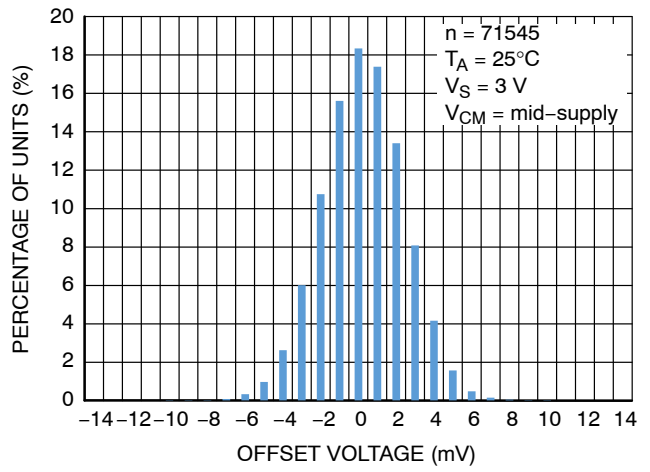
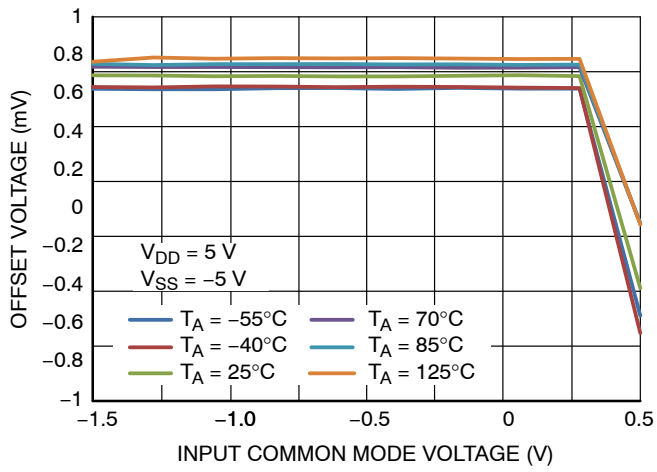

Figure 11.  $V_{OS}$  vs.  $V_{CM}$  ( $V_S = 5\text{ V}$ )

# NCV2393, TS393



# MECHANICAL CASE OUTLINE

## PACKAGE DIMENSIONS

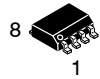

SCALE 1:1

**SOIC-8 NB**  
CASE 751-07  
ISSUE AK

DATE 16 FEB 2011

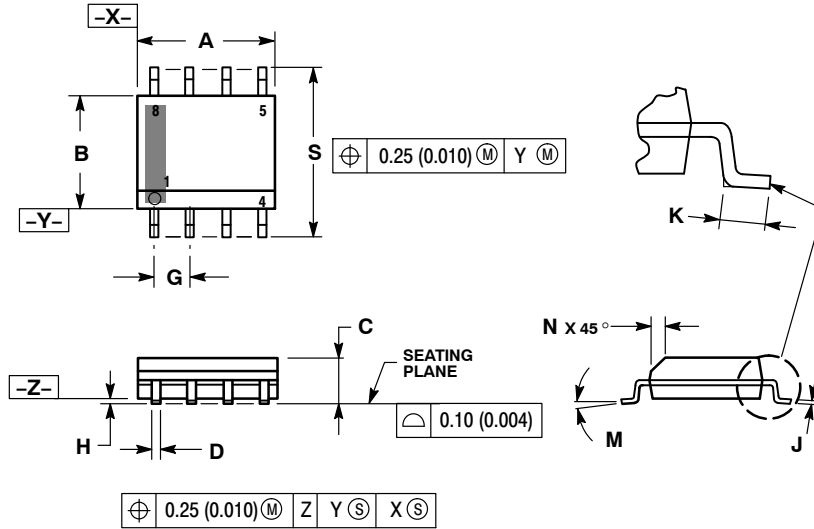

- NOTES:
1. DIMENSIONING AND TOLERANCING PER ANSI Y14.5M, 1982.
  2. CONTROLLING DIMENSION: MILLIMETER.
  3. DIMENSION A AND B DO NOT INCLUDE MOLD PROTRUSION.
  4. MAXIMUM MOLD PROTRUSION 0.15 (0.006) PER SIDE.
  5. DIMENSION D DOES NOT INCLUDE DAMBAR PROTRUSION. ALLOWABLE DAMBAR PROTRUSION SHALL BE 0.127 (0.005) TOTAL IN EXCESS OF THE D DIMENSION AT MAXIMUM MATERIAL CONDITION.
  6. 751-01 THRU 751-06 ARE OBSOLETE. NEW STANDARD IS 751-07.

DIM	MILLIMETERS		INCHES	
	MIN	MAX	MIN	MAX
A	4.80	5.00	0.189	0.197
B	3.80	4.00	0.150	0.157
C	1.35	1.75	0.053	0.069
D	0.33	0.51	0.013	0.020
G	1.27 BSC		0.050 BSC	
H	0.10	0.25	0.004	0.010
J	0.19	0.25	0.007	0.010
K	0.40	1.27	0.016	0.050
M	0°	8°	0°	8°
N	0.25	0.50	0.010	0.020
S	5.80	6.20	0.228	0.244

### GENERIC MARKING DIAGRAM\*

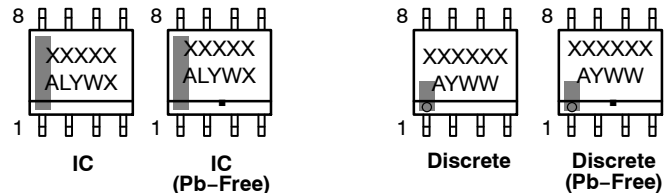
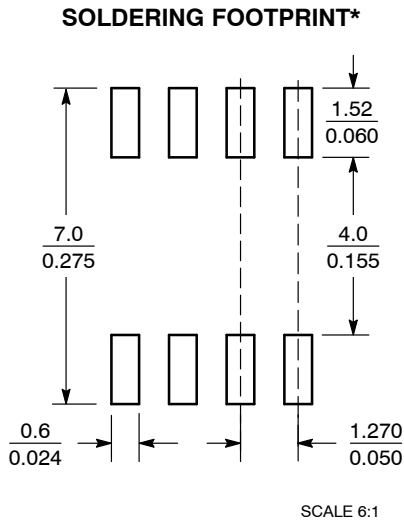

XXXXXX = Specific Device Code  
 A = Assembly Location  
 L = Wafer Lot  
 Y = Year  
 W = Work Week  
 ■ = Pb-Free Package

XXXXXX = Specific Device Code  
 A = Assembly Location  
 Y = Year  
 WW = Work Week  
 ■ = Pb-Free Package

\*This information is generic. Please refer to device data sheet for actual part marking. Pb-Free indicator, "G" or microdot "■", may or may not be present. Some products may not follow the Generic Marking.

\*For additional information on our Pb-Free strategy and soldering details, please download the ON Semiconductor Soldering and Mounting Techniques Reference Manual, SOLDERM/D.

STYLES ON PAGE 2

<b>DOCUMENT NUMBER:</b>	<b>98ASB42564B</b>	Electronic versions are uncontrolled except when accessed directly from the Document Repository. Printed versions are uncontrolled except when stamped "CONTROLLED COPY" in red.
<b>DESCRIPTION:</b>	<b>SOIC-8 NB</b>	<b>PAGE 1 OF 2</b>



SOIC-8 NB  
CASE 751-07  
ISSUE AK

DATE 16 FEB 2011

STYLE 1:

PIN 1. EMITTER  
2. COLLECTOR  
3. COLLECTOR  
4. EMITTER  
5. EMITTER  
6. BASE  
7. BASE  
8. EMITTER

STYLE 5:

PIN 1. DRAIN  
2. DRAIN  
3. DRAIN  
4. DRAIN  
5. GATE  
6. GATE  
7. SOURCE  
8. SOURCE

STYLE 9:

PIN 1. EMITTER, COMMON  
2. COLLECTOR, DIE #1  
3. COLLECTOR, DIE #2  
4. EMITTER, COMMON  
5. EMITTER, COMMON  
6. BASE, DIE #2  
7. BASE, DIE #1  
8. EMITTER, COMMON

STYLE 13:

PIN 1. N.C.  
2. SOURCE  
3. SOURCE  
4. GATE  
5. DRAIN  
6. DRAIN  
7. DRAIN  
8. DRAIN

STYLE 17:

PIN 1. VCC  
2. V2OUT  
3. V1OUT  
4. TXE  
5. RXE  
6. VEE  
7. GND  
8. ACC

STYLE 21:

PIN 1. CATHODE 1  
2. CATHODE 2  
3. CATHODE 3  
4. CATHODE 4  
5. CATHODE 5  
6. COMMON ANODE  
7. COMMON ANODE  
8. CATHODE 6

STYLE 25:

PIN 1. VIN  
2. N/C  
3. REXT  
4. GND  
5. IOUT  
6. IOUT  
7. IOUT  
8. IOUT

STYLE 29:

PIN 1. BASE, DIE #1  
2. EMITTER, #1  
3. BASE, #2  
4. EMITTER, #2  
5. COLLECTOR, #2  
6. COLLECTOR, #2  
7. COLLECTOR, #1  
8. COLLECTOR, #1

STYLE 2:

PIN 1. COLLECTOR, DIE, #1  
2. COLLECTOR, #1  
3. COLLECTOR, #2  
4. COLLECTOR, #2  
5. BASE, #2  
6. EMITTER, #2  
7. BASE, #1  
8. EMITTER, #1

STYLE 6:

PIN 1. SOURCE  
2. DRAIN  
3. DRAIN  
4. SOURCE  
5. SOURCE  
6. GATE  
7. GATE  
8. SOURCE

STYLE 10:

PIN 1. GROUND  
2. BIAS 1  
3. OUTPUT  
4. GROUND  
5. GROUND  
6. BIAS 2  
7. INPUT  
8. GROUND

STYLE 14:

PIN 1. N-SOURCE  
2. N-GATE  
3. P-SOURCE  
4. P-GATE  
5. P-DRAIN  
6. P-DRAIN  
7. N-DRAIN  
8. N-DRAIN

STYLE 18:

PIN 1. ANODE  
2. ANODE  
3. SOURCE  
4. GATE  
5. DRAIN  
6. DRAIN  
7. CATHODE  
8. CATHODE

STYLE 22:

PIN 1. I/O LINE 1  
2. COMMON CATHODE/VCC  
3. COMMON CATHODE/VCC  
4. I/O LINE 3  
5. COMMON ANODE/GND  
6. I/O LINE 4  
7. I/O LINE 5  
8. COMMON ANODE/GND

STYLE 26:

PIN 1. GND  
2. dv/dt  
3. ENABLE  
4. ILIMIT  
5. SOURCE  
6. SOURCE  
7. SOURCE  
8. VCC

STYLE 30:

PIN 1. DRAIN 1  
2. DRAIN 1  
3. GATE 2  
4. SOURCE 2  
5. SOURCE 1/DRAIN 2  
6. SOURCE 1/DRAIN 2  
7. SOURCE 1/DRAIN 2  
8. GATE 1

STYLE 3:

PIN 1. DRAIN, DIE #1  
2. DRAIN, #1  
3. DRAIN, #2  
4. DRAIN, #2  
5. GATE, #2  
6. SOURCE, #2  
7. GATE, #1  
8. SOURCE, #1

STYLE 7:

PIN 1. INPUT  
2. EXTERNAL BYPASS  
3. THIRD STAGE SOURCE  
4. GROUND  
5. DRAIN  
6. GATE 3  
7. SECOND STAGE Vd  
8. FIRST STAGE Vd

STYLE 11:

PIN 1. SOURCE 1  
2. GATE 1  
3. SOURCE 2  
4. GATE 2  
5. DRAIN 2  
6. DRAIN 2  
7. DRAIN 1  
8. DRAIN 1

STYLE 15:

PIN 1. ANODE 1  
2. ANODE 1  
3. ANODE 1  
4. ANODE 1  
5. CATHODE, COMMON  
6. CATHODE, COMMON  
7. CATHODE, COMMON  
8. CATHODE, COMMON

STYLE 19:

PIN 1. SOURCE 1  
2. GATE 1  
3. SOURCE 2  
4. GATE 2  
5. DRAIN 2  
6. MIRROR 2  
7. DRAIN 1  
8. MIRROR 1

STYLE 23:

PIN 1. LINE 1 IN  
2. COMMON ANODE/GND  
3. COMMON ANODE/GND  
4. LINE 2 IN  
5. LINE 2 OUT  
6. COMMON ANODE/GND  
7. COMMON ANODE/GND  
8. LINE 1 OUT

STYLE 27:

PIN 1. ILIMIT  
2. OVLO  
3. UVLO  
4. INPUT+  
5. SOURCE  
6. SOURCE  
7. SOURCE  
8. DRAIN

STYLE 4:

PIN 1. ANODE  
2. ANODE  
3. ANODE  
4. ANODE  
5. ANODE  
6. ANODE  
7. ANODE  
8. COMMON CATHODE

STYLE 8:

PIN 1. COLLECTOR, DIE #1  
2. BASE, #1  
3. BASE, #2  
4. COLLECTOR, #2  
5. COLLECTOR, #2  
6. EMITTER, #2  
7. EMITTER, #1  
8. COLLECTOR, #1

STYLE 12:

PIN 1. SOURCE  
2. SOURCE  
3. SOURCE  
4. GATE  
5. DRAIN  
6. DRAIN  
7. DRAIN  
8. DRAIN

STYLE 16:

PIN 1. EMITTER, DIE #1  
2. BASE, DIE #1  
3. EMITTER, DIE #2  
4. BASE, DIE #2  
5. COLLECTOR, DIE #2  
6. COLLECTOR, DIE #2  
7. COLLECTOR, DIE #1  
8. COLLECTOR, DIE #1

STYLE 20:

PIN 1. SOURCE (N)  
2. GATE (N)  
3. SOURCE (P)  
4. GATE (P)  
5. DRAIN  
6. DRAIN  
7. DRAIN  
8. DRAIN

STYLE 24:

PIN 1. BASE  
2. EMITTER  
3. COLLECTOR/ANODE  
4. COLLECTOR/ANODE  
5. CATHODE  
6. CATHODE  
7. COLLECTOR/ANODE  
8. COLLECTOR/ANODE

STYLE 28:

PIN 1. SW\_TO\_GND  
2. DASIC\_OFF  
3. DASIC\_SW\_DET  
4. GND  
5. V\_MON  
6. VBULK  
7. VBULK  
8. VIN