

# U74HC14

CMOS IC

## HIGH-SPEED CMOS LOGIC HEX INVERTING SCHMITT TRIGGER

### DESCRIPTION

The UTC **U74HC14** each contain six inverting Schmitt triggers in one package. Each of them perform the Boolean function  $Y = \bar{A}$

### FEATURES

- \* Widely range of input rise and fall time
- \* high noise immunity
- \* Fan-out parameters(over temperature range) up to 10 LSTTL Loads
- \* Low power consumption
- \* Wide range operation 2V ~ 6V

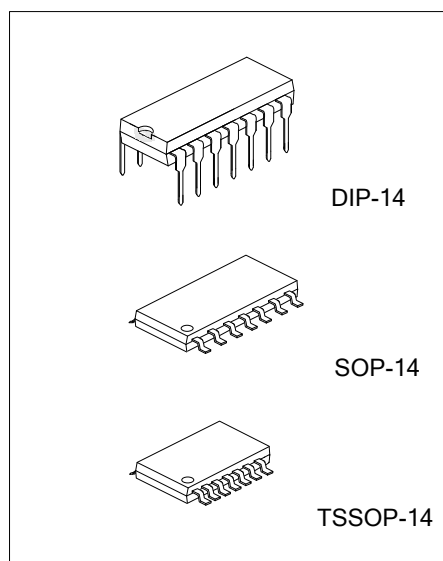

### ORDERING INFORMATION

Ordering Number		Package	Packing
Lead Free	Halogen Free		
U74HC14L-D14-T	U74HC14G-D14-T	DIP-14	Tube
U74HC14L-S14-R	U74HC14G-S14-R	SOP-14	Tape Reel
U74HC14L-P14-R	U74HC14G-P14-R	TSSOP-14	Tape Reel

<p>U74HC14G-D14-T</p> <p>(1)Packing Type (2)Package Type (3)Green Package</p>	<p>(1) R: Tape Reel, T: Tube (2) D14: DIP-14, P14: TSSOP-14, S14: SOP-14 (3) G: Halogen Free and Lead Free, L: Lead Free</p>
---	--

### MARKING

DIP-14	SOP-14 / TSSOP-14

■ PIN CONFIGURATION

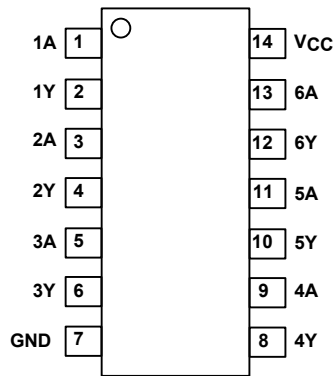

■ FUNCTIONAL DIAGRAM

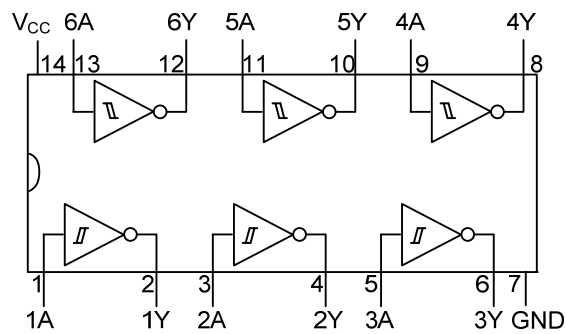

■ TRUTH TABLE

INPUT(A)	OUTPUT(Y)
L	H
H	L

H=High level

L=Low Level

■ LOGIC DIAGRAM

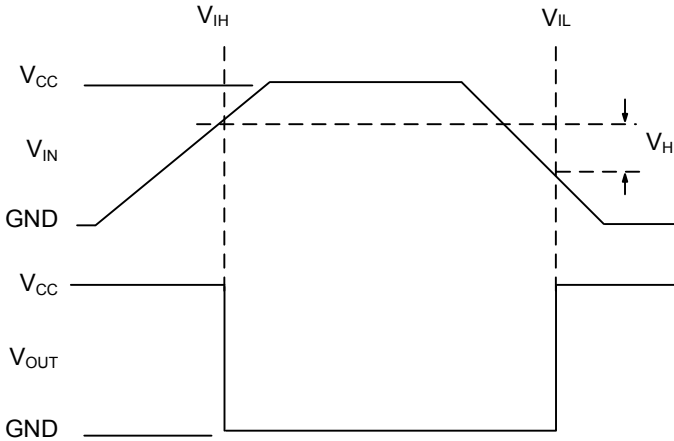
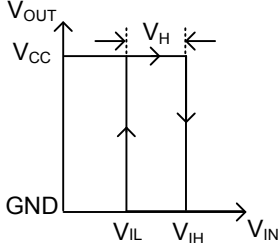
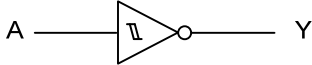

Hysteresis Definition, Characteristic, And Test Setup

### ■ ABSOLUTE MAXIMUM RATINGS

PARAMETER		SYMBOL	RATINGS	UNIT
Supply Voltage		$V_{CC}$	-0.5V ~ 7V	V
Input Clamp Current	For $V_{IN} < 0$ or $V_{IN} > V_{CC}$	$I_{IK}$	$\pm 20$	mA
Output Clamp Current	For $V_{OUT} < 0$ or $V_{OUT} > V_{CC}$	$I_{OK}$	$\pm 20$	mA
Continuous Output Current	For $V_{OUT} = 0$ to $V_{CC}$	$I_{OUT}$	$\pm 25$	mA
$V_{CC}$ or Ground Current		$I_{CC}$	$\pm 50$	mA
Storage Temperature		$T_{STG}$	-65 ~ +150	°C

Note: Absolute maximum ratings are those values beyond which the device could be permanently damaged. Absolute maximum ratings are stress ratings only and functional device operation is not implied.

### ■ THERMAL DATA

PARAMETER		SYMBOL	RATINGS	UNIT
Thermal Resistance Junction Ambient	DIP-14	$\theta_{JA}$	80	°C/W
	SOP-14		76	°C/W
	TSSOP-14		113	°C/W

### ■ RECOMMENDED OPERATING CONDITIONS

PARAMETER	SYMBOL	CONDITIONS	MIN	TYP	MAX	UNIT
Supply Voltage Range HC Types	$V_{CC}$		2	5	6	V
Input or Output Voltage	$V_{IN}, V_{OUT}$		0		$V_{CC}$	V
Operating Temperature	$T_A$		-40		85	°C

### ■ ELECTRICAL CHARACTERISTICS ( $T_A = 25^\circ\text{C}$ , unless otherwise specified)

PARAMETER	SYMBOL	TEST CONDITIONS	MIN	TYP	MAX	UNIT
Input Switch Points	$V_{IH}$	$V_{CC}=2V$	0.7	1.2	1.5	
		$V_{CC}=4.5V$	1.55	2.5	3.15	
		$V_{CC}=6V$	2.1	3.3	4.2	
	$V_{IL}$	$V_{CC}=2V$	0.3	0.6	1	V
		$V_{CC}=4.5V$	0.9	1.6	2.45	V
		$V_{CC}=6V$	1.2	2	3.2	V
	$V_{TH}$	$V_{CC}=2V$	0.2	0.6	1.2	V
		$V_{CC}=4.5V$	0.4	0.9	2.1	V
		$V_{CC}=6V$	0.5	1.3	2.5	V
High Level Output Voltage CMOS Loads	$V_{OH}$	$V_{IN}=V_{IH}$ or $V_{IL}, V_{CC}=2V, I_{OH}=-0.02mA$	1.9			V
$V_{IN}=V_{IH}$ or $V_{IL}, V_{CC}=4.5V, I_{OH}=-0.02mA$		4.4			V	
$V_{IN}=V_{IH}$ or $V_{IL}, V_{CC}=6V, I_{OH}=-0.02mA$		5.9			V	
High Level Output Voltage TTL Loads	$V_{OH}$	$V_{IN}=V_{IH}$ or $V_{IL}, V_{CC}=4.5V, I_{OH}=-4mA$	3.98			V
$V_{IN}=V_{IH}$ or $V_{IL}, V_{CC}=6V, I_{OH}=-5.2mA$		5.48			V	
Low Level Output Voltage CMOS Loads	$V_{OL}$	$V_{IN}=V_{IH}$ or $V_{IL}, V_{CC}=2V, I_{OL}=0.02mA$			0.1	V
$V_{IN}=V_{IH}$ or $V_{IL}, V_{CC}=4.5V, I_{OL}=0.02mA$				0.1	V	
$V_{IN}=V_{IH}$ or $V_{IL}, V_{CC}=6V, I_{OL}=0.02mA$				0.1	V	
Low Level Output Voltage TTL Loads	$V_{OL}$	$V_{IN}=V_{IH}$ or $V_{IL}, V_{CC}=4.5V, I_{OL}=4mA$			0.26	V
$V_{IN}=V_{IH}$ or $V_{IL}, V_{CC}=6V, I_{OL}=5.2mA$				0.26	V	
Input Leakage Current	$I_{IN}$	$V_{IN}=V_{CC}$ and GND, $V_{CC}=6V$			$\pm 0.1$	$\mu A$
Quiescent Device Current	$I_Q$	$V_{IN}=V_{CC}$ or GND, $V_{CC}=6V, I_{OUT}=0$			2	$\mu A$

■ SWITCHING SPECIFICATIONS ( $T_A = 25^\circ\text{C}$ , Input  $t_R, t_F = 6\text{ns}$ , unless otherwise specified)

PARAMETER	SYMBOL	TEST CONDITIONS	MIN	TYP	MAX	UNIT
Propagation Delay, A to Y	$t_{PLH}, t_{PHL}$	$V_{CC}=2\text{V}, C_L=50\text{pF}$		55	125	ns
		$V_{CC}=4.5\text{V}, C_L=50\text{pF}$		12	25	ns
		$V_{CC}=6\text{V}, C_L=50\text{pF}$		11	21	ns
Output Transition Times	$t_{TLH}, t_{THL}$	$V_{CC}=2\text{V}, C_L=50\text{pF}$		38	75	ns
		$V_{CC}=4.5\text{V}, C_L=50\text{pF}$		8	15	ns
		$V_{CC}=6\text{V}, C_L=50\text{pF}$		6	13	ns
Input Capacitance	$C_{IN}$			3	10	pF
Power Dissipation Capacitance	$C_{PD}$	No load		20		pF

■ TEST CIRCUIT AND WAVEFORMS

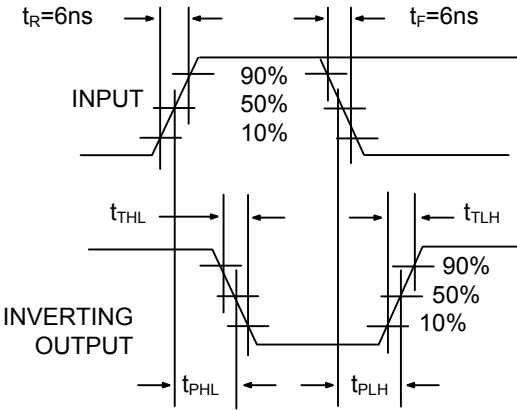

Transition Times And Propagation Delay Times, Combination Logic