

LM2840/LM2841/LM2842/ LM2840-Q1/LM2841-Q1/LM2842-Q1 100/300/600 mA 42V Input Step-Down DC/DC Regulator in Thin SOT

Check for Samples: [LM2841](#), [LM2842](#)

FEATURES

- LM2840Q, LM2841-Q1 and LM2842-Q1 are Automotive Grade Products that are AEC-Q100 Grade 1 Qualified (-40°C to +125°C Operating Junction Temperature)
- Input Voltage Range of 4.5V to 42V
- Output Current Options of 100 mA, 300 mA and 600 mA
- Feedback Pin Voltage of 0.765V
- 550 kHz (X) or 1.25 MHz (Y) Switching Frequency
- Low Shutdown I_Q , 16 μ A Typical
- Short Circuit Protected
- Internally Compensated
- Soft-Start Circuitry
- Small Overall Solution Size (SOT-6L Package)

APPLICATIONS

- Battery Powered Equipment
- Industrial Distributed Power Applications
- Portable Media Players
- Portable Hand Held Instruments

Typical Application Circuit

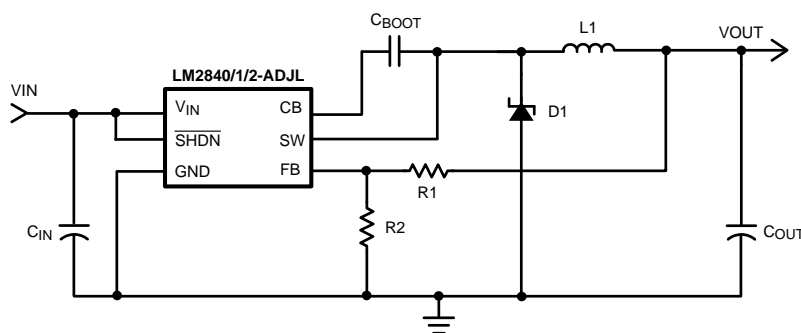

DESCRIPTION

The LM2840, LM2841 and LM2842 are PWM DC/DC buck (step-down) regulators. With a wide input range from 4.5V-42V, they are suitable for a wide range of applications such as power conditioning from unregulated sources. They feature a low $R_{DS(ON)}$ (0.9 Ω typical) internal switch for maximum efficiency (85% typical). Operating frequency is fixed at 550 kHz (X version) and 1.25 MHz (Y version) allowing the use of small external components while still being able to have low output voltage ripple. Soft-start can be implemented using the shutdown pin with an external RC circuit allowing the user to tailor the soft-start time to a specific application.

The LM2840 is optimized for up to 100 mA, the LM2841 for 300 mA and the LM2842 is optimized for up to 600 mA load currents. They all have a 0.765V nominal feedback voltage.

Additional features include: thermal shutdown, V_{IN} under-voltage lockout, and gate drive under-voltage lockout. The LM2840, LM2841 and LM2842 are available in a low profile SOT-6L package.

Connection Diagram

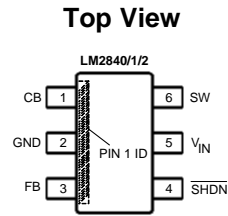

**Figure 1. SOT 6 Lead
See Package Number DDC (R-PDSO-G6)**

PIN DESCRIPTIONS

Pin	Name	Function
1	CB	SW FET gate bias voltage. Connect C _{BOOT} cap between CB and SW.
2	GND	Ground connection.
3	FB	Feedback pin: Set feedback voltage divider ratio with $V_{OUT} = V_{FB} (1+(R1/R2))$. Resistors should be in the 100-10K range to avoid input bias errors.
4	$\overline{\text{SHDN}}$	Logic level shutdown input. Pull to GND to disable the device and pull high to enable the device. If this function is not used tie to V _{IN} or leave open.
5	V _{IN}	Power input voltage pin: 4.5V to 42V normal operating range.
6	SW	Power FET output: Connect to inductor, diode, and C _{BOOT} cap.



These devices have limited built-in ESD protection. The leads should be shorted together or the device placed in conductive foam during storage or handling to prevent electrostatic damage to the MOS gates.

Absolute Maximum Ratings ⁽¹⁾⁽²⁾

V_{IN}		-0.3V to +45V
\overline{SHDN}		-0.3V to $(V_{IN}+0.3V) < 45V$
SW Voltage		-0.3V to +45V
CB Voltage above SW Voltage		7V
FB Voltage		-0.3V to +5V
Maximum Junction Temperature		150°C
Power Dissipation ⁽³⁾		Internally Limited
Lead Temperature		300°C
Vapor Phase (60 sec.)		215°C
Infrared (15 sec.)		220°C
ESD Susceptibility ⁽⁴⁾	Human Body Model	2 kV

- (1) Absolute maximum ratings are limits beyond which damage to the device may occur. Operating Ratings are conditions for which the device is intended to be functional, but device parameter specifications may not be ensured. For ensured specifications and test conditions, see the Electrical Characteristics.
- (2) If Military/Aerospace specified devices are required, please contact the Texas Instruments Sales Office/ Distributors for availability and specifications.
- (3) The maximum allowable power dissipation is a function of the maximum junction temperature, $T_{J(MAX)}$, the junction-to-ambient thermal resistance, θ_{JA} , and the ambient temperature, T_A . The maximum allowable power dissipation at any ambient temperature is calculated using: $P_D (MAX) = (T_{J(MAX)} - T_A)/\theta_{JA}$. Exceeding the maximum allowable power dissipation will cause excessive die temperature, and the regulator will go into thermal shutdown. Internal thermal shutdown circuitry protects the device from permanent damage. Thermal shutdown engages at $T_J=175^\circ\text{C}$ (typ.) and disengages at $T_J= 155^\circ\text{C}$ (typ.).
- (4) Human Body Model, applicable std. JESD22-A114-C.

Operating Conditions

Operating Junction Temperature Range ⁽¹⁾	-40°C to +125°C
Storage Temperature	-65°C to +150°C
Input Voltage V_{IN}	4.5V to 42V
SW Voltage	Up to 42V

- (1) All limits specified at room temperature (standard typeface) and at temperature extremes (bold typeface). All room temperature limits are 100% production tested. All limits at temperature extremes are ensured via correlation using standard Statistical Quality Control (SQC) methods. All limits are used to calculate Average Outgoing Quality Level (AOQL).

Electrical Characteristics

Specifications in standard type face are for $T_J = 25^\circ\text{C}$ and those with **boldface type** apply over the full **Operating Temperature Range** ($T_J = -40^\circ\text{C}$ to $+125^\circ\text{C}$). Minimum and Maximum limits are specified through test, design, or statistical correlation. Typical values represent the most likely parametric norm at $T_J = +25^\circ\text{C}$, and are provided for reference purposes only. Unless otherwise stated the following conditions apply: $V_{IN} = 12V$.

Symbol	Parameter	Conditions	Min ⁽¹⁾	Typ ⁽²⁾	Max ⁽¹⁾	Units
I_Q	Quiescent current	$\overline{SHDN} = 0V$		16	40	μA
		Device On, Not Switching		1.30	1.75	mA
		Device On, No Load		1.35	1.85	
R_{DSON}	Switch ON resistance	See ⁽³⁾		0.9	1.6	Ω
I_{LSW}	Switch leakage current	$V_{IN} = 42V$		0.0	0.5	μA
I_{CL}	Switch current limit	LM2840 ⁽⁴⁾		525	900	mA
		LM2841 ⁽⁴⁾		525	900	mA
		LM2842 ⁽⁴⁾		1.15	1.7	A
I_{FB}	Feedback pin bias current	LM2840/41/42 ⁽⁵⁾		0.1	1.0	μA
V_{FB}	FB Pin reference voltage		0.747	0.765	0.782	V

- (1) All limits specified at room temperature (standard typeface) and at temperature extremes (bold typeface). All room temperature limits are 100% production tested. All limits at temperature extremes are ensured via correlation using standard Statistical Quality Control (SQC) methods. All limits are used to calculate Average Outgoing Quality Level (AOQL).
- (2) Typical numbers are at 25°C and represent the most likely norm.
- (3) Includes the bond wires, R_{DSON} from V_{IN} pin to SW pin.
- (4) Current limit at 0% duty cycle. May be lower at higher duty cycle or input voltages below 6V.
- (5) Bias currents flow into pin.

LM2841, LM2842

SNVS540H – MARCH 2009 – REVISED APRIL 2013

Electrical Characteristics (continued)

Specifications in standard type face are for $T_J = 25^\circ\text{C}$ and those with **boldface type** apply over the full **Operating Temperature Range** ($T_J = -40^\circ\text{C}$ to $+125^\circ\text{C}$). Minimum and Maximum limits are specified through test, design, or statistical correlation. Typical values represent the most likely parametric norm at $T_J = +25^\circ\text{C}$, and are provided for reference purposes only. Unless otherwise stated the following conditions apply: $V_{IN} = 12\text{V}$.

Symbol	Parameter	Conditions	Min ⁽¹⁾	Typ ⁽²⁾	Max ⁽¹⁾	Units
$t_{ON(min)}$	Minimum ON time	See ⁽⁶⁾		100	150	ns
$t_{OFF(min)}$	Minimum OFF time	X option		110	370	ns
		Y option		104	200	ns
f_{SW}	Switching frequency	LM2840/41/42X, $V_{FB} = 0.5\text{V}$	325	550	750	kHz
		LM2840/41/42X, $V_{FB} = 0\text{V}$		140		
		LM2840/41/42Y, $V_{FB} = 0.5\text{V}$	0.95	1.25	1.50	MHz
		LM2840/41/42Y, $V_{FB} = 0\text{V}$		0.35		
D_{MAX}	Maximum duty cycle	LM2840/41/42X	88	94		%
		LM2840/41/42Y	81	87		
V_{UVP}	Undervoltage lockout thresholds	On threshold	4.4	3.7		V
		Off threshold		3.5	3.25	
V_{SHDN}	Shutdown threshold	Device on	2.3	1.0		V
		Device off		0.9	0.3	
I_{SHDN}	Shutdown pin input bias current	$V_{SHDN} = 2.3\text{V}$ ⁽⁵⁾		0.05	1.5	μA
		$V_{SHDN} = 0\text{V}$		0.02	1.5	
THERMAL SPECIFICATIONS						
$R_{\theta JA}$	Junction-to-Ambient Thermal Resistance, SOT-6L Package	See ⁽⁷⁾		121		$^\circ\text{C/W}$
$R_{\theta JC}$	Junction-to-Case Thermal Resistance, SOT-6L Package			94		$^\circ\text{C/W}$

(6) Minimum On Time specified by design and simulation.

(7) All numbers apply for packages soldered directly onto a 3" x 3" PC board with 2 oz. copper on 4 layers in still air in accordance to JEDEC standards. Thermal resistance varies greatly with layout, copper thickness, number of layers in PCB, power distribution, number of thermal vias, board size, ambient temperature, and air flow.

Typical Performance Characteristics

Efficiency vs. Load Current (LM2842X, $V_{OUT} = 3.3V$)

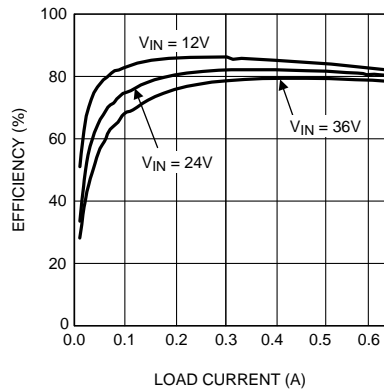

Figure 2.

Efficiency vs. Load Current (LM2841X, $V_{OUT} = 3.3V$)

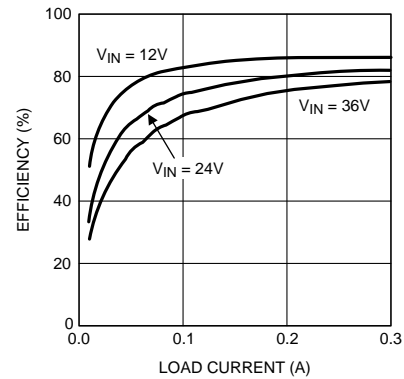

Figure 3.

Efficiency vs. Load Current (LM2840X, $V_{OUT} = 8V$)

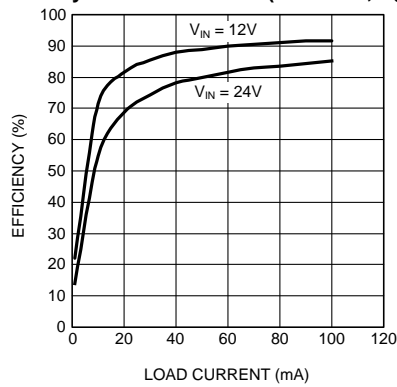

Figure 4.

Switching Frequency vs. Temperature (X version)

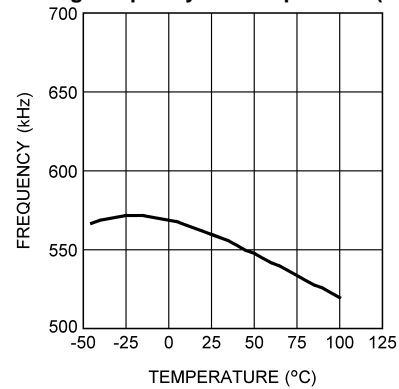

Figure 5.

Input UVLO Voltage vs. Temperature

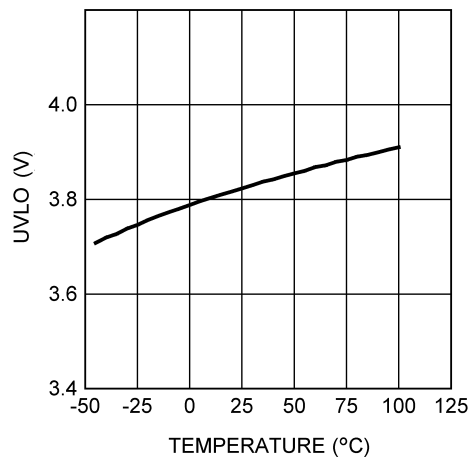

Figure 6.

Switch Current Limit vs. \overline{SHDN} Pin Voltage (Soft-start Implementation, LM2840/41)

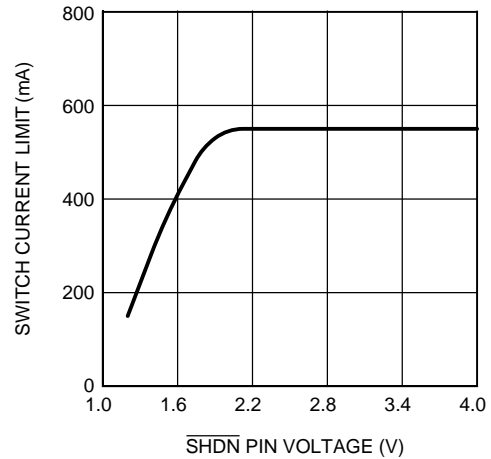

Figure 7.

Typical Performance Characteristics (continued)

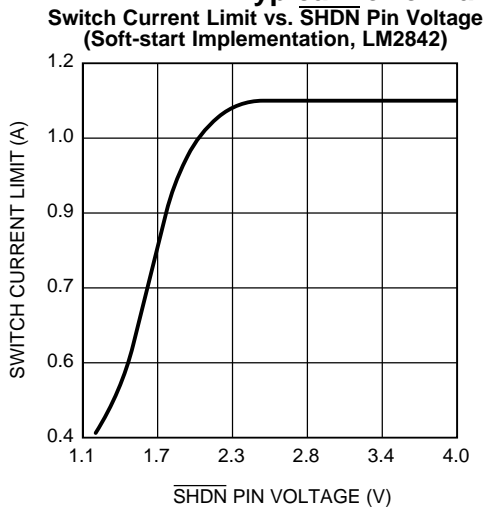

Figure 8.

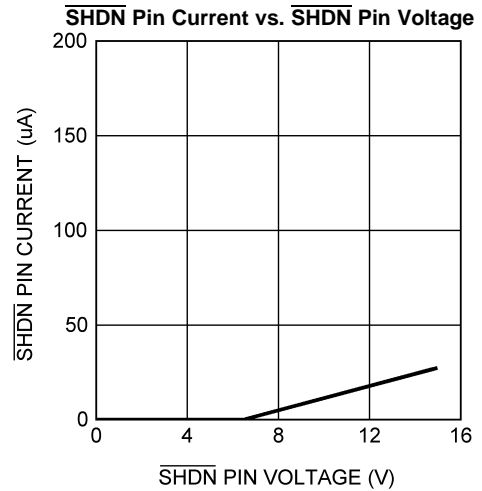
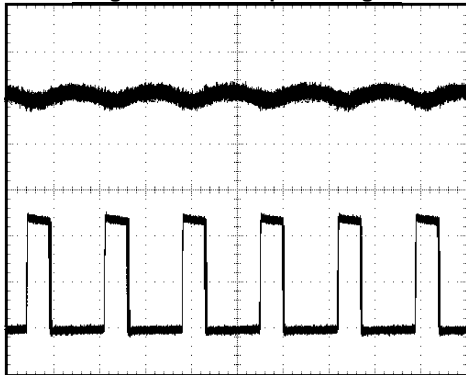

Figure 9.

Switching Node and Output Voltage Waveforms



$V_{\text{IN}} = 12\text{V}$, $V_{\text{OUT}} = 3.3\text{V}$, $I_{\text{OUT}} = 200\text{ mA}$
Top trace: V_{OUT} , 10 mV/div, AC Coupled
Bottom trace: SW, 5V/div, DC Coupled
 $T = 1\ \mu\text{s/div}$

Figure 10.

Load Transient Waveforms



$V_{\text{IN}} = 12\text{V}$, $V_{\text{OUT}} = 3.3\text{V}$, $I_{\text{OUT}} = 300\text{ mA to } 200\text{ mA to } 300\text{ mA}$
Top trace: V_{OUT} , 20 mV/div, AC Coupled
Bottom trace: I_{OUT} , 100 mA/div, DC Coupled
 $T = 200\ \mu\text{s/div}$

Figure 11.

Start-up Waveform

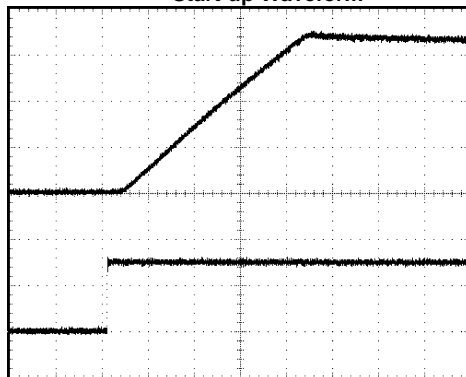

$V_{\text{IN}} = 12\text{V}$, $V_{\text{OUT}} = 3.3\text{V}$, $I_{\text{OUT}} = 50\text{ mA}$
Top trace: V_{OUT} , 1V/div, DC Coupled
Bottom trace: $\overline{\text{SHDN}}$, 2V/div, DC Coupled
 $T = 40\ \mu\text{s/div}$

Figure 12.

BLOCK DIAGRAM

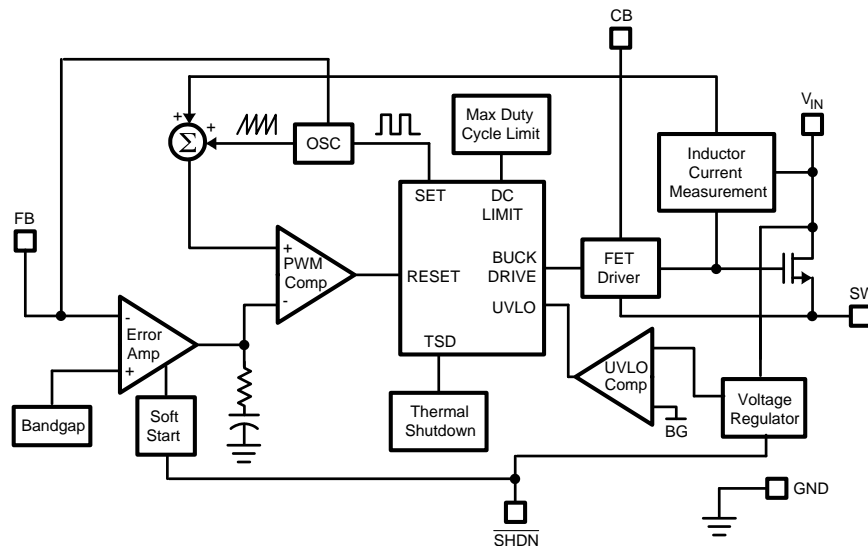

Figure 13. Block Diagram

OPERATION

PROTECTION

The LM2840/1/2 has dedicated protection circuitry running during normal operation to protect the IC. The thermal shutdown circuitry turns off the power device when the die temperature reaches excessive levels. The UVLO comparator protects the power device during supply power startup and shutdown to prevent operation at voltages less than the minimum input voltage. A gate drive (CB) under-voltage lockout is included to ensure that there is enough gate drive voltage to drive the MOSFET before the device tries to start switching. The LM2840/1/2 also features a shutdown mode decreasing the supply current to approximately 16 μA .

CONTINUOUS CONDUCTION MODE

The LM2840/1/2 contains a current-mode, PWM buck regulator. A buck regulator steps the input voltage down to a lower output voltage. In continuous conduction mode (when the inductor current never reaches zero at steady state), the buck regulator operates in two cycles. The power switch is connected between V_{IN} and SW. In the first cycle of operation the transistor is closed and the diode is reverse biased. Energy is collected in the inductor and the load current is supplied by C_{OUT} and the rising current through the inductor. During the second cycle the transistor is open and the diode is forward biased due to the fact that the inductor current cannot instantaneously change direction. The energy stored in the inductor is transferred to the load and output capacitor. The ratio of these two cycles determines the output voltage. The output voltage is defined approximately as: $D=V_{OUT}/V_{IN}$ and $D' = (1-D)$ where D is the duty cycle of the switch. D and D' will be required for design calculations.

DESIGN PROCEDURE

This section presents guidelines for selecting external components.

SETTING THE OUTPUT VOLTAGE

The output voltage is set using the feedback pin and a resistor divider connected to the output as shown on the front page schematic. The feedback pin voltage 0.765V, so the ratio of the feedback resistors sets the output voltage according to the following equation: $V_{OUT}=0.765V(1+(R1/R2))$

Typically R2 will be given as 100 Ω -10 k Ω for a starting value. To solve for R1 given R2 and V_{OUT} use $R1=R2((V_{OUT}/0.765V)-1)$.

INPUT CAPACITOR

A low ESR ceramic capacitor (C_{IN}) is needed between the V_{IN} pin and GND pin. This capacitor prevents large voltage transients from appearing at the input. Use a 2.2 μF -10 μF value with X5R or X7R dielectric. Depending on construction, a ceramic capacitor's value can decrease up to 50% of its nominal value when rated voltage is applied. Consult with the capacitor manufacturer's data sheet for information on capacitor derating over voltage and temperature.

INDUCTOR SELECTION

The most critical parameters for the inductor are the inductance, peak current, and the DC resistance. The inductance is related to the peak-to-peak inductor ripple current, the input and the output voltages.

$$L = \frac{(V_{IN} - V_{OUT})V_{OUT}}{V_{IN} \times I_{RIPPLE} \times f_{SW}} \quad (1)$$

A higher value of ripple current reduces inductance, but increases the conductance loss, core loss, and current stress for the inductor and switch devices. It also requires a bigger output capacitor for the same output voltage ripple requirement. A reasonable value is setting the ripple current to be 30% of the DC output current. Since the ripple current increases with the input voltage, the maximum input voltage is always used to determine the inductance. The DC resistance of the inductor is a key parameter for the efficiency. Lower DC resistance is available with a bigger winding area. A good tradeoff between the efficiency and the core size is letting the inductor copper loss equal 2% of the output power. See AN-1197 [SNVA038](#) for more information on selecting inductors. A good starting point for most applications is a 10 μH to 22 μH with 1.1A or greater current rating for the LM2842 or a 0.7A or greater current rating for the LM2840/41. Using such a rating will enable the LM2840/1/2 to current limit without saturating the inductor. This is preferable to the LM2840/1/2 going into thermal shutdown mode and the possibility of damaging the inductor if the output is shorted to ground or other longterm overload.

OUTPUT CAPACITOR

The selection of C_{OUT} is driven by the maximum allowable output voltage ripple. The output ripple in the constant frequency, PWM mode is approximated by: $V_{RIPPLE} = I_{RIPPLE}(ESR + (1/(8f_{SW}C_{OUT})))$ The ESR term usually plays the dominant role in determining the voltage ripple. Low ESR ceramic capacitors are recommended. Capacitors in the range of 22 μF -100 μF are a good starting point with an ESR of 0.1 Ω or less.

BOOTSTRAP CAPACITOR

A 0.15 μF ceramic capacitor or larger is recommended for the bootstrap capacitor (C_{BOOT}). For applications where the input voltage is less than twice the output voltage a larger capacitor is recommended, generally 0.15 μF to 1 μF to ensure plenty of gate drive for the internal switches and a consistently low $R_{DS(ON)}$.

SOFT-START COMPONENTS

The LM2840/1/2 has circuitry that is used in conjunction with the $\overline{\text{SHDN}}$ pin to limit the inrush current on start-up of the DC/DC switching regulator. The $\overline{\text{SHDN}}$ pin in conjunction with a RC filter is used to tailor the soft-start for a specific application. When a voltage applied to the $\overline{\text{SHDN}}$ pin is between 0V and up to 2.3V it will cause the cycle by cycle current limit in the power stage to be modulated for minimum current limit at 0V up to the rated current limit at 2.3V. Thus controlling the output rise time and inrush current at startup. The resistor value should be selected so the current sourced into the $\overline{\text{SHDN}}$ pin will be greater than the leakage current of the $\overline{\text{SHDN}}$ pin (1.5 μA) when the voltage at $\overline{\text{SHDN}}$ is equal or greater than 2.3V.

SHUTDOWN OPERATION

The $\overline{\text{SHDN}}$ pin of the LM2840/1/2 is designed so that it may be controlled using 2.3V or higher logic signals. If the shutdown function is not to be used the $\overline{\text{SHDN}}$ pin may be tied to V_{IN} . The maximum voltage to the $\overline{\text{SHDN}}$ pin should not exceed 42V. If the use of a higher voltage is desired due to system or other constraints it may be used, however a 100 k Ω or larger resistor is recommended between the applied voltage and the $\overline{\text{SHDN}}$ pin to protect the device.

SCHOTTKY DIODE

The breakdown voltage rating of the diode (D1) is preferred to be 25% higher than the maximum input voltage. The current rating for the diode should be equal to the maximum output current for best reliability in most applications. In cases where the duty cycle is greater than 50%, the average diode current is lower. In this case it is possible to use a diode with a lower average current rating, approximately $(1-D)I_{OUT}$, however the peak current rating should be higher than the maximum load current. A 0.5A to 1A rated diode is a good starting point.

LAYOUT CONSIDERATIONS

To reduce problems with conducted noise pick up, the ground side of the feedback network should be connected directly to the GND pin with its own connection. The feedback network, resistors R1 and R2, should be kept close to the FB pin, and away from the inductor to minimize coupling noise into the feedback pin. The input bypass capacitor C_{IN} must be placed close to the V_{IN} pin. This will reduce copper trace resistance which effects input voltage ripple of the IC. The inductor L1 should be placed close to the SW pin to reduce EMI and capacitive coupling. The output capacitor, C_{OUT} should be placed close to the junction of L1 and the diode D1. The L1, D1, and C_{OUT} trace should be as short as possible to reduce conducted and radiated noise and increase overall efficiency. The ground connection for the diode, C_{IN} , and C_{OUT} should be as small as possible and tied to the system ground plane in only one spot (preferably at the C_{OUT} ground point) to minimize conducted noise in the system ground plane. For more detail on switching power supply layout considerations see Application Note AN-1149: *Layout Guidelines for Switching Power Supplies* [SNVA021](#).

Application Information

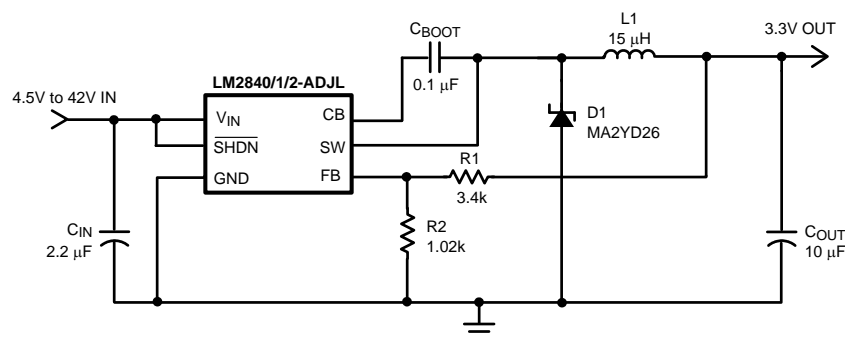

Figure 14. Application Circuit, 3.3V Output @ 100 mA

Table 1. Some Recommended Inductors (Others May Be Used)

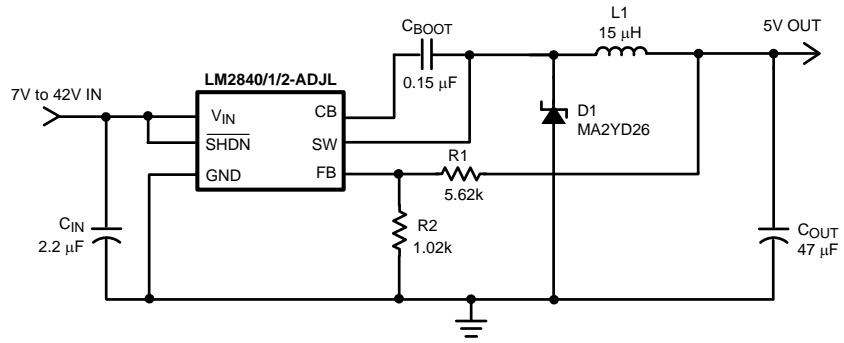

Figure 15. Application Circuit, 5V Output

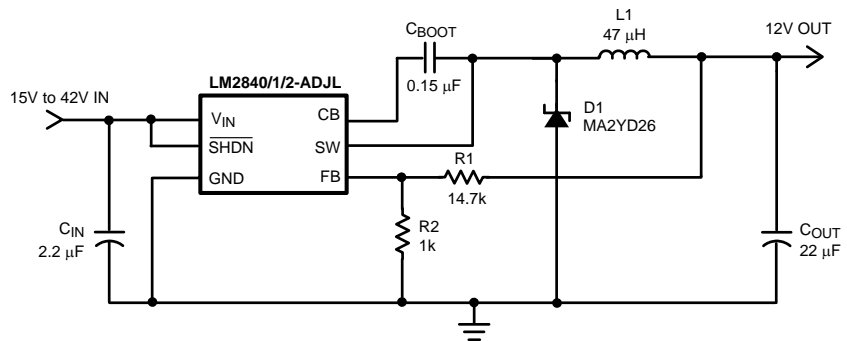

Figure 16. Application Circuit, 12V Output

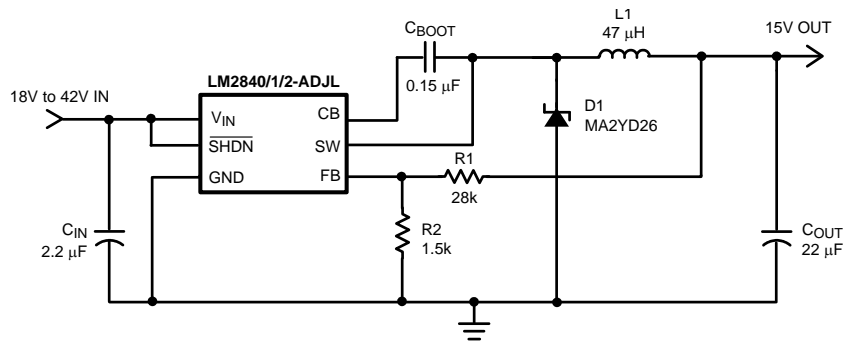

Figure 17. Application Circuit, 15V Output

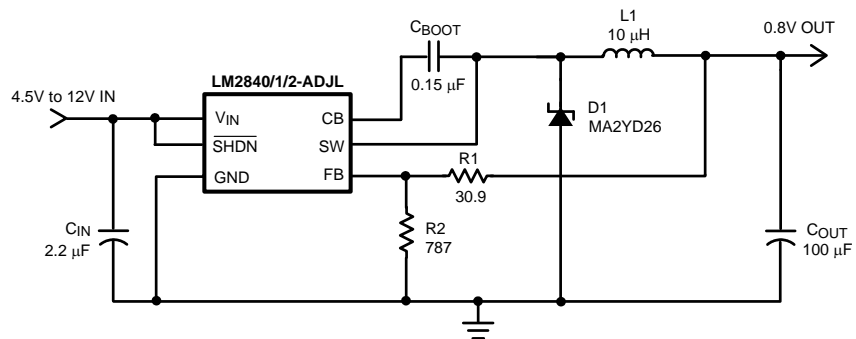

Figure 18. Application Circuit, 0.8V Output

PACKAGE OPTION ADDENDUM

8-Oct-2015

PACKAGING INFORMATION

Orderable Device	Status (1)	Package Type	Package Drawing	Pins	Package Qty	Eco Plan (2)	Lead/Ball Finish (6)	MSL Peak Temp (3)	Op Temp (°C)	Device Marking (4/5)	Samples
LM2840XMK-ADJL/NOPB	ACTIVE	SOT	DDC	6	1000	Green (RoHS & no Sb/Br)	CU SN	Level-1-260C-UNLIM	-40 to 125	SE8B	Samples
LM2840XMKX-ADJL/NOPB	ACTIVE	SOT	DDC	6	3000	Green (RoHS & no Sb/Br)	CU SN	Level-1-260C-UNLIM	-40 to 125	SE8B	Samples
LM2840XQMK/NOPB	ACTIVE	SOT	DDC	6	1000	Green (RoHS & no Sb/Br)	CU SN	Level-1-260C-UNLIM	-40 to 125	SE9B	Samples
LM2840YMK-ADJL/NOPB	ACTIVE	SOT	DDC	6	1000	Green (RoHS & no Sb/Br)	CU SN	Level-1-260C-UNLIM	-40 to 125	SF1B	Samples
LM2840YQMK/NOPB	ACTIVE	SOT	DDC	6	1000	Green (RoHS & no Sb/Br)	CU SN	Level-1-260C-UNLIM	-40 to 125	SF2B	Samples
LM2840YQMKX/NOPB	ACTIVE	SOT	DDC	6	3000	Green (RoHS & no Sb/Br)	CU SN	Level-1-260C-UNLIM	-40 to 125	SF2B	Samples
LM2841XMK-ADJL/NOPB	ACTIVE	SOT	DDC	6	1000	Green (RoHS & no Sb/Br)	CU SN	Level-1-260C-UNLIM	-40 to 125	STFB	Samples
LM2841XMKX-ADJL/NOPB	ACTIVE	SOT	DDC	6	3000	Green (RoHS & no Sb/Br)	CU SN	Level-1-260C-UNLIM	-40 to 125	STFB	Samples
LM2841XQMK/NOPB	ACTIVE	SOT	DDC	6	1000	Green (RoHS & no Sb/Br)	CU SN	Level-1-260C-UNLIM	-40 to 125	SB1B	Samples
LM2841YMK-ADJL/NOPB	ACTIVE	SOT	DDC	6	1000	Green (RoHS & no Sb/Br)	CU SN	Level-1-260C-UNLIM	-40 to 125	STTB	Samples
LM2841YMKX-ADJL/NOPB	ACTIVE	SOT	DDC	6	3000	Green (RoHS & no Sb/Br)	CU SN	Level-1-260C-UNLIM	-40 to 125	STTB	Samples
LM2841YQMK/NOPB	ACTIVE	SOT	DDC	6	1000	Green (RoHS & no Sb/Br)	CU SN	Level-1-260C-UNLIM	-40 to 125	SB2B	Samples
LM2841YQMKX/NOPB	ACTIVE	SOT	DDC	6	3000	Green (RoHS & no Sb/Br)	CU SN	Level-1-260C-UNLIM	-40 to 125	SB2B	Samples
LM2842XMK-ADJL/NOPB	ACTIVE	SOT	DDC	6	1000	Green (RoHS & no Sb/Br)	CU SN	Level-1-260C-UNLIM	-40 to 125	STVB	Samples
LM2842XMKX-ADJL/NOPB	ACTIVE	SOT	DDC	6	3000	Green (RoHS & no Sb/Br)	CU SN	Level-1-260C-UNLIM	-40 to 125	STVB	Samples
LM2842XQMK/NOPB	ACTIVE	SOT	DDC	6	1000	Green (RoHS & no Sb/Br)	CU SN	Level-1-260C-UNLIM	-40 to 125	SB3B	Samples
LM2842XQMKX/NOPB	ACTIVE	SOT	DDC	6	3000	Green (RoHS & no Sb/Br)	CU SN	Level-1-260C-UNLIM	-40 to 125	SB3B	Samples

PACKAGE OPTION ADDENDUM

8-Oct-2015

Orderable Device	Status (1)	Package Type	Package Drawing	Pins	Package Qty	Eco Plan (2)	Lead/Ball Finish (6)	MSL Peak Temp (3)	Op Temp (°C)	Device Marking (4/5)	Samples
LM2842YMK-ADJL/NOPB	ACTIVE	SOT	DDC	6	1000	Green (RoHS & no Sb/Br)	CU SN	Level-1-260C-UNLIM	-40 to 125	STXB	Samples
LM2842YMKX-ADJL/NOPB	ACTIVE	SOT	DDC	6	3000	Green (RoHS & no Sb/Br)	CU SN	Level-1-260C-UNLIM	-40 to 125	STXB	Samples
LM2842YQMK/NOPB	ACTIVE	SOT	DDC	6	1000	Green (RoHS & no Sb/Br)	CU SN	Level-1-260C-UNLIM	-40 to 125	SB4B	Samples
LM2842YQMKX/NOPB	ACTIVE	SOT	DDC	6	3000	Green (RoHS & no Sb/Br)	CU SN	Level-1-260C-UNLIM	-40 to 125	SB4B	Samples

continues to take reasonable steps to provide representative and accurate information but may not have conducted destructive testing or chemical analysis on incoming materials and chemicals. TI and TI suppliers consider certain information to be proprietary, and thus CAS numbers and other limited information may not be available for release.

In no event shall TI's liability arising out of such information exceed the total purchase price of the TI part(s) at issue in this document sold by TI to Customer on an annual basis.

OTHER QUALIFIED VERSIONS OF LM2840, LM2840-Q1, LM2841, LM2841-Q1, LM2842, LM2842-Q1 :

- Catalog: [LM2840](#), [LM2841](#), [LM2842](#)
- Automotive: [LM2840-Q1](#), [LM2841-Q1](#), [LM2842-Q1](#)

NOTE: Qualified Version Definitions:

- Catalog - TI's standard catalog product
- Automotive - Q100 devices qualified for high-reliability automotive applications targeting zero defects

TAPE AND REEL INFORMATION

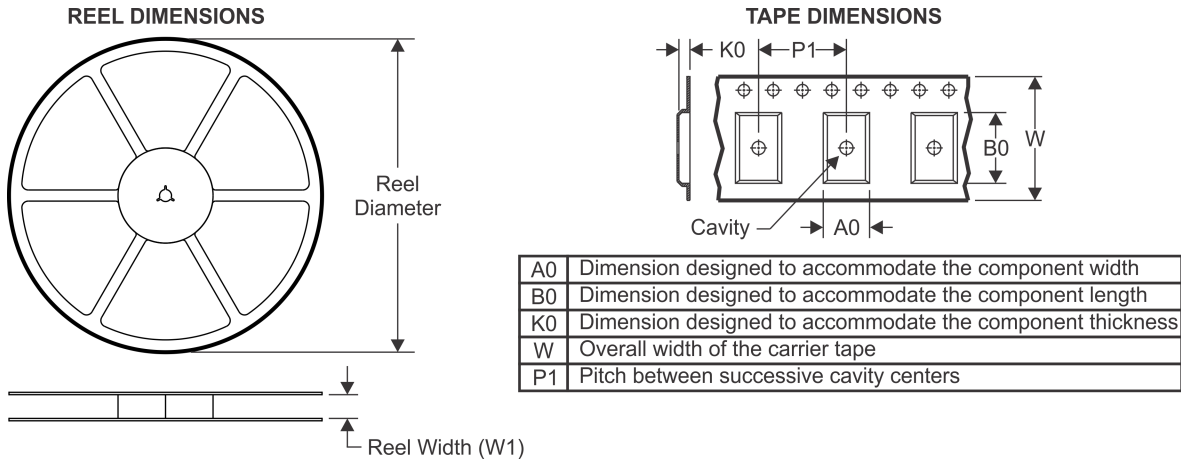

QUADRANT ASSIGNMENTS FOR PIN 1 ORIENTATION IN TAPE

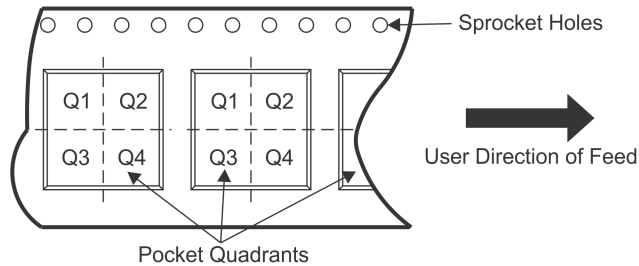

*All dimensions are nominal

Device	Package Type	Package Drawing	Pins	SPQ	Reel Diameter (mm)	Reel Width W1 (mm)	A0 (mm)	B0 (mm)	K0 (mm)	P1 (mm)	W (mm)	Pin1 Quadrant
LM2840XMK-ADJL/NOPB	SOT	DDC	6	1000	178.0	8.4	3.2	3.2	1.4	4.0	8.0	Q3
LM2840XMKX-ADJL/NOPB	SOT	DDC	6	3000	178.0	8.4	3.2	3.2	1.4	4.0	8.0	Q3
LM2840XQMK/NOPB	SOT	DDC	6	1000	178.0	8.4	3.2	3.2	1.4	4.0	8.0	Q3
LM2840YMK-ADJL/NOPB	SOT	DDC	6	1000	178.0	8.4	3.2	3.2	1.4	4.0	8.0	Q3
LM2840YQMK/NOPB	SOT	DDC	6	1000	178.0	8.4	3.2	3.2	1.4	4.0	8.0	Q3
LM2840YQMKX/NOPB	SOT	DDC	6	3000	178.0	8.4	3.2	3.2	1.4	4.0	8.0	Q3
LM2841XMK-ADJL/NOPB	SOT	DDC	6	1000	178.0	8.4	3.2	3.2	1.4	4.0	8.0	Q3
LM2841XMKX-ADJL/NOPB	SOT	DDC	6	3000	178.0	8.4	3.2	3.2	1.4	4.0	8.0	Q3
LM2841XQMK/NOPB	SOT	DDC	6	1000	178.0	8.4	3.2	3.2	1.4	4.0	8.0	Q3
LM2841YMK-ADJL/NOPB	SOT	DDC	6	1000	178.0	8.4	3.2	3.2	1.4	4.0	8.0	Q3
LM2841YMKX-ADJL/NOPB	SOT	DDC	6	3000	178.0	8.4	3.2	3.2	1.4	4.0	8.0	Q3
LM2841YQMK/NOPB	SOT	DDC	6	1000	178.0	8.4	3.2	3.2	1.4	4.0	8.0	Q3
LM2841YQMKX/NOPB	SOT	DDC	6	3000	178.0	8.4	3.2	3.2	1.4	4.0	8.0	Q3
LM2842XMK-ADJL/NOPB	SOT	DDC	6	1000	178.0	8.4	3.2	3.2	1.4	4.0	8.0	Q3
LM2842XMKX-ADJL/NOPB	SOT	DDC	6	3000	178.0	8.4	3.2	3.2	1.4	4.0	8.0	Q3

PACKAGE MATERIALS INFORMATION

2-Sep-2015

Device	Package Type	Package Drawing	Pins	SPQ	Reel Diameter (mm)	Reel Width W1 (mm)	A0 (mm)	B0 (mm)	K0 (mm)	P1 (mm)	W (mm)	Pin1 Quadrant
LM2842XQMK/NOPB	SOT	DDC	6	1000	178.0	8.4	3.2	3.2	1.4	4.0	8.0	Q3
LM2842XQMKX/NOPB	SOT	DDC	6	3000	178.0	8.4	3.2	3.2	1.4	4.0	8.0	Q3
LM2842YMK-ADJL/NOPB	SOT	DDC	6	1000	178.0	8.4	3.2	3.2	1.4	4.0	8.0	Q3
LM2842YMKX-ADJL/NOPB	SOT	DDC	6	3000	178.0	8.4	3.2	3.2	1.4	4.0	8.0	Q3
LM2842YQMK/NOPB	SOT	DDC	6	1000	178.0	8.4	3.2	3.2	1.4	4.0	8.0	Q3
LM2842YQMKX/NOPB	SOT	DDC	6	3000	178.0	8.4	3.2	3.2	1.4	4.0	8.0	Q3

TAPE AND REEL BOX DIMENSIONS

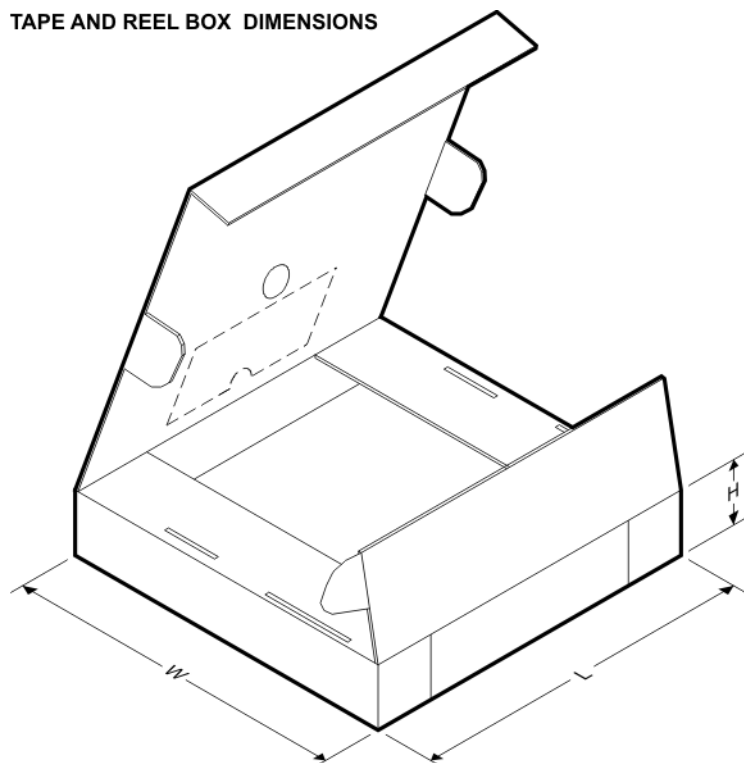

*All dimensions are nominal

Device	Package Type	Package Drawing	Pins	SPQ	Length (mm)	Width (mm)	Height (mm)
LM2840XMK-ADJL/NOPB	SOT	DDC	6	1000	210.0	185.0	35.0
LM2840XMKX-ADJL/NOPB	SOT	DDC	6	3000	210.0	185.0	35.0
LM2840XQMK/NOPB	SOT	DDC	6	1000	210.0	185.0	35.0
LM2840YMK-ADJL/NOPB	SOT	DDC	6	1000	210.0	185.0	35.0
LM2840YQMK/NOPB	SOT	DDC	6	1000	210.0	185.0	35.0
LM2840YQMKX/NOPB	SOT	DDC	6	3000	210.0	185.0	35.0
LM2841XMK-ADJL/NOPB	SOT	DDC	6	1000	210.0	185.0	35.0
LM2841XMKX-ADJL/NOPB	SOT	DDC	6	3000	210.0	185.0	35.0
LM2841XQMK/NOPB	SOT	DDC	6	1000	210.0	185.0	35.0

PACKAGE MATERIALS INFORMATION

2-Sep-2015

Device	Package Type	Package Drawing	Pins	SPQ	Length (mm)	Width (mm)	Height (mm)
LM2841YMK-ADJL/NOPB	SOT	DDC	6	1000	210.0	185.0	35.0
LM2841YMKX-ADJL/NOP B	SOT	DDC	6	3000	210.0	185.0	35.0
LM2841YQMK/NOPB	SOT	DDC	6	1000	210.0	185.0	35.0
LM2841YQMKX/NOPB	SOT	DDC	6	3000	210.0	185.0	35.0
LM2842XMK-ADJL/NOPB	SOT	DDC	6	1000	210.0	185.0	35.0
LM2842XMKX-ADJL/NOP B	SOT	DDC	6	3000	210.0	185.0	35.0
LM2842XQMK/NOPB	SOT	DDC	6	1000	210.0	185.0	35.0
LM2842XQMKX/NOPB	SOT	DDC	6	3000	210.0	185.0	35.0
LM2842YMK-ADJL/NOPB	SOT	DDC	6	1000	210.0	185.0	35.0
LM2842YMKX-ADJL/NOP B	SOT	DDC	6	3000	210.0	185.0	35.0
LM2842YQMK/NOPB	SOT	DDC	6	1000	210.0	185.0	35.0
LM2842YQMKX/NOPB	SOT	DDC	6	3000	210.0	185.0	35.0

DDC (R-PDSO-G6)

PLASTIC SMALL-OUTLINE

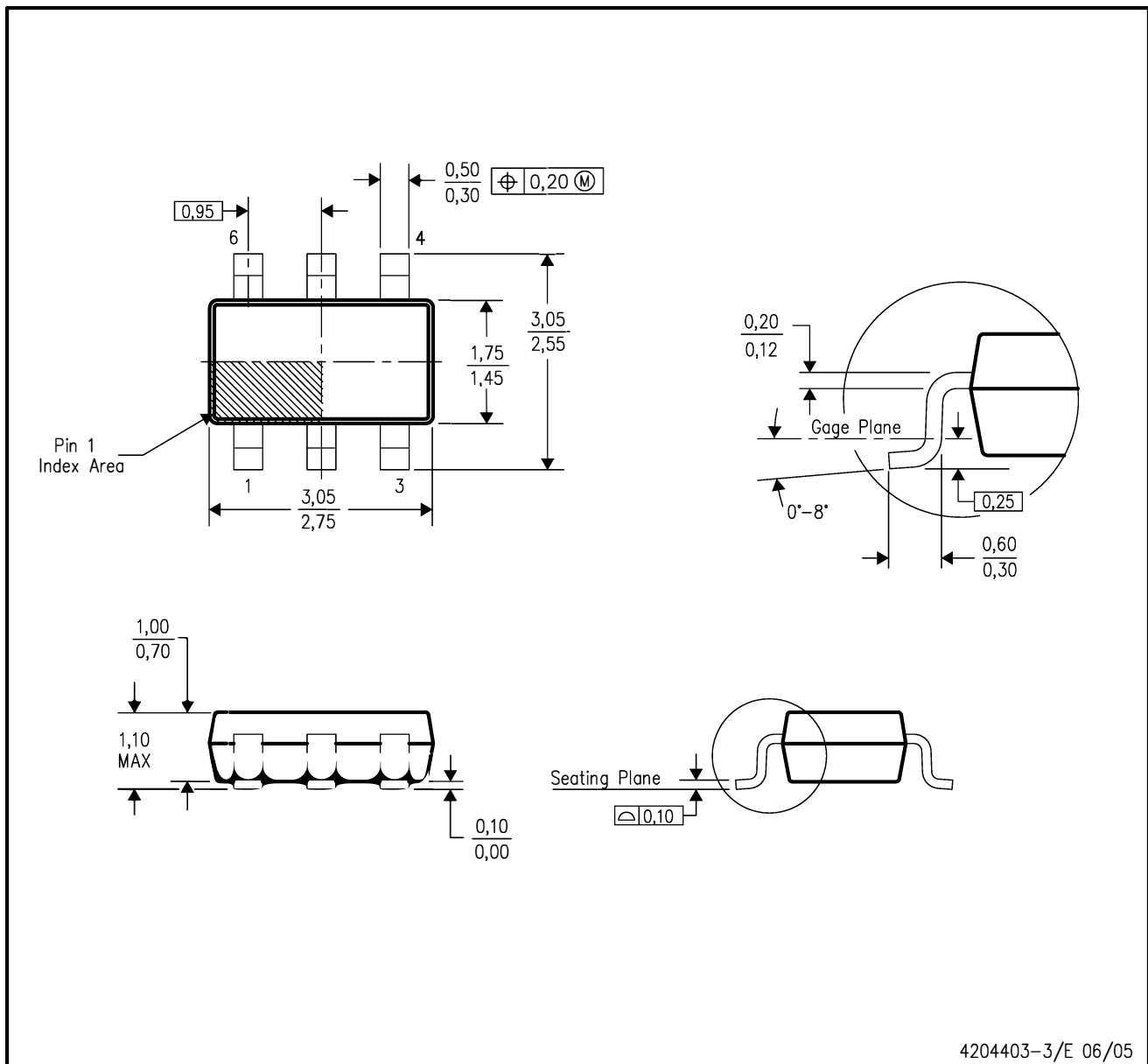

- NOTES:
- All linear dimensions are in millimeters.
 - This drawing is subject to change without notice.
 - Body dimensions do not include mold flash or protrusion.
 - Falls within JEDEC MO-193 variation AA (6 pin).

DDC (R-PDSO-G6)

PLASTIC SMALL OUTLINE

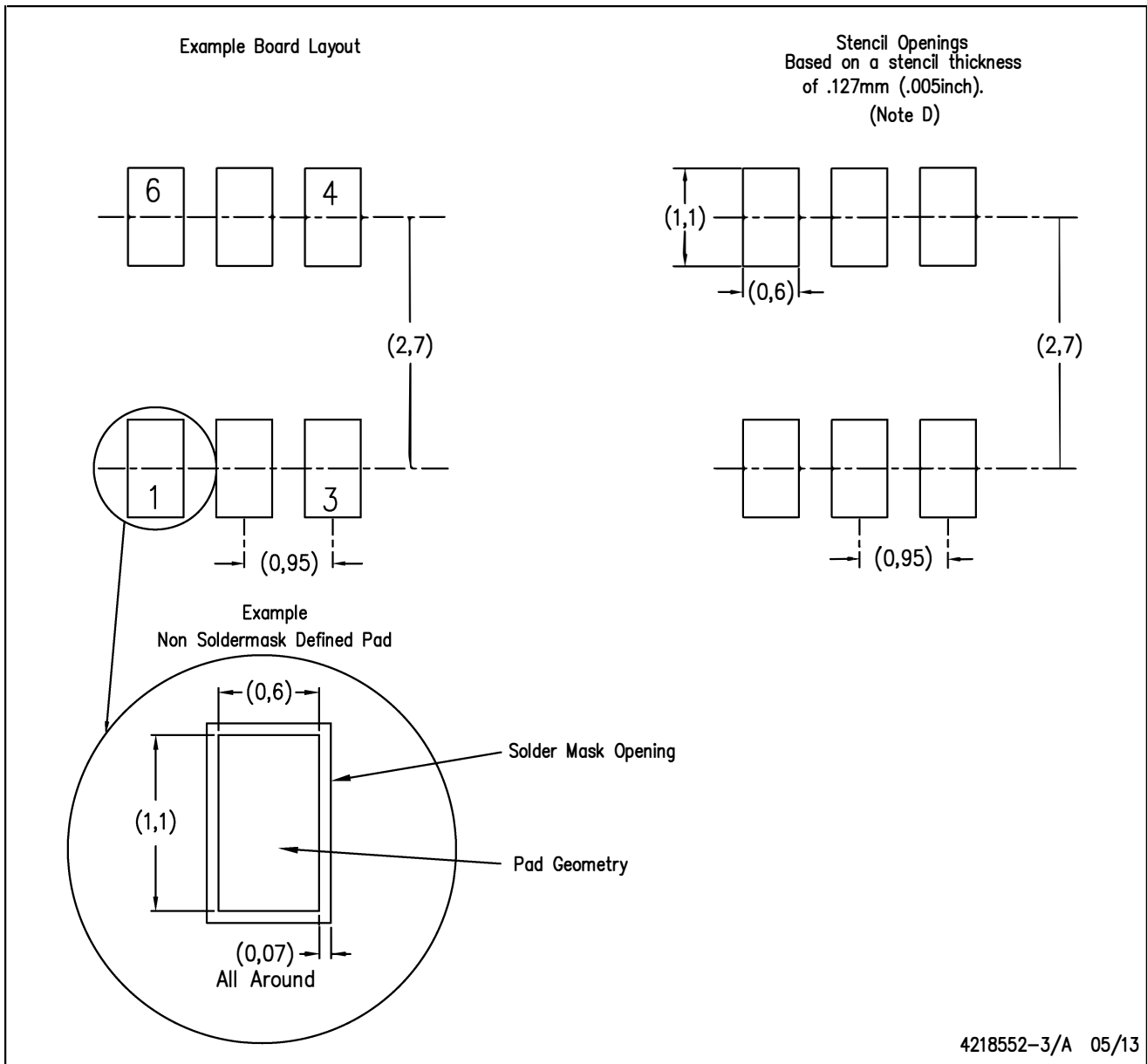

- NOTES:
- All linear dimensions are in millimeters.
 - This drawing is subject to change without notice.
 - Publication IPC-7351 is recommended for alternate designs.
 - Laser cutting apertures with trapezoidal walls and also rounding corners will offer better paste release. Customers should contact their board assembly site for stencil design recommendations. Example stencil design based on a 50% volumetric metal load solder paste. Refer to IPC-7525 for other stencil recommendations.