

Revision History

Document No.: BGS12PL6.pdf

Previous Version: v2.4, May 27, 2014

Page	Subjects (major changes since last revision)
7	Updated Features
9	Updated Operation Ranges

Trademarks of Infineon Technologies AG

AURIX™, C166™, CanPAK™, CIPOS™, CIPURSE™, CoolGaN™, CoolMOS™, CoolSET™, CoolSiC™, CORECONTROL™, DAVE™, DI-POL™, EasyPIM™, EconoBRIDGE™, EconoDUAL™, EconoPACK™, EconoPIM™, EiceDRIVER™, eupec™, FCOS™, HITFET™, HybridPACK™, ISOFACE™, I²RF™, IsoPACK™, MIPAQ™, ModSTACK™, my-d™, NovalithIC™, OmniTune™, OptiMOS™, ORIGA™, OPTIGA™, PROFET™, PRO-SIL™, PRIMARION™, PrimePACK™, RASIC™, ReverSave™, SatRIC™, SIEGET™, SIPMOS™, SOLID FLASH™, SmartLEWIS™, TEMPFET™, thinQ!™, TriCore™, TRENCHSTOP™.

Other Trademarks

Advance Design System™ (ADS) of Agilent Technologies, AMBA™, ARM™, MULTI-ICE™, PRIMECELL™, REALVIEW™, THUMB™ of ARM Limited, UK. AUTOSAR™ is licensed by AUTOSAR development partnership. Bluetooth™ of Bluetooth SIG Inc. CAT-iq™ of DECT Forum. COLOSSUS™, FirstGPS™ of Trimble Navigation Ltd. EMV™ of EMVCo, LLC (Visa Holdings Inc.). EPCOS™ of Epcos AG. FLEXGO™ of Microsoft Corporation. FlexRay™ is licensed by FlexRay Consortium. HYPERTERMINAL™ of Hilgraeve Incorporated. IEC™ of Commission Electrotechnique Internationale. IrDA™ of Infrared Data Association Corporation. ISO™ of INTERNATIONAL ORGANIZATION FOR STANDARDIZATION. MATLAB™ of MathWorks, Inc. MAXIM™ of Maxim Integrated Products, Inc. MICROTEC™, NUCLEUS™ of Mentor Graphics Corporation. Mifare™ of NXP. MIPI™ of MIPI Alliance, Inc. MIPS™ of MIPS Technologies, Inc., USA. muRata™ of MURATA MANUFACTURING CO., MICROWAVE OFFICE™ (MWO) of Applied Wave Research Inc., OmniVision™ of OmniVision Technologies, Inc. Openwave™ Openwave Systems Inc. RED HAT™ Red Hat, Inc. RFMD™ RF Micro Devices, Inc. SIRIUS™ of Sirius Sattelite Radio Inc. SOLARIS™ of Sun Microsystems, Inc. SPANSION™ of Spansion LLC Ltd. Symbian™ of Symbian Software Limited. TAIYO YUDEN™ of Taiyo Yuden Co. TEAKLITE™ of CEVA, Inc. TEKTRONIX™ of Tektronix Inc. TOKO™ of TOKO KABUSHIKI KAISHA TA. UNIX™ of X/Open Company Limited. VERILOG™, PALLADIUM™ of Cadence Design Systems, Inc. VLYNQ™ of Texas Instruments Incorporated. VXWORKS™, WIND RIVER™ of WIND RIVER SYSTEMS, INC. ZETEX™ of Diodes Zetex Limited.

Last Trademarks Update 2012-12-13

Contents

1 Features	7
2 Product Description	7
3 Maximum Ratings	9
4 Operation Ranges	9
5 RF Characteristics	10
6 Pin Description	12
7 Package Information	12

List of Figures

1	BGS12PL6 Block Diagram	8
2	Pin Configuration	12
3	Package Outline	13
4	Footprint	13
5	Pin 1 Marking (top view)	13
6	Tape Drawing for TSLP-6-4	14

List of Tables

1	Ordering Information	7
2	Truth Table	8
3	Maximum Ratings	9
4	Operation Ranges	9
5	RF Input Power	9
6	RF Characteristics	10
7	Pin Description	12
8	Mechanical Data	12

BGS12PL6 General purpose RF CMOS power SPDT Switch in ultra small package with 0.77mm² footprint

1 Features

- 2 high-linearity TRx paths with power handling capability of up to 35 dBm
- All ports fully symmetrical
- Low insertion loss
- Low harmonic generation
- High port-to-port isolation
- 30 MHz to 4 GHz coverage
- High ESD robustness
- On-chip control logic
- Very small leadless and halogen free package TSLP-6-4 (0.7x1.1mm²) with super low height of 0.31 mm
- No decoupling capacitors required if no DC applied on RF lines
- RoHS compliant package

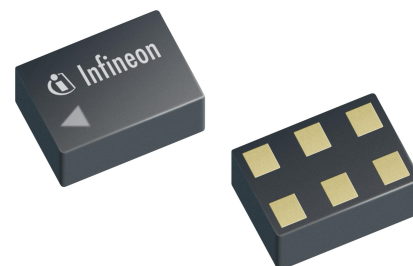

2 Product Description

The BGS12PL6 general purpose RF MOS power switch is designed to cover a broad range of high power applications from 30 MHz to 4 GHz, mainly in the transmit path of GSM, WCDMA and LTE mobile phones. The symmetric design of its single pole double throw configuration, as shown in Figure 1 offers high design flexibility.

This single supply chip integrates on-chip CMOS logic driven by a simple, single-pin CMOS or TTL compatible control input signal. The 0.1 dB compression point exceeds the switch's maximum input power level of 35 dBm, resulting in linear performance at all signal levels. The RF switch has a very low insertion loss of 0.36 dB in the 1 GHz, 0.46 dB in the 2 GHz and 0.6 dB in the 3 GHz range.

The BGS12PL6 RF switch is manufactured in Infineon's patented MOS technology, offering the performance of GaAs with the economy and integration of conventional CMOS including the inherent higher ESD robustness.

The device has a very small size of only 0.7x 1.1mm² and a low height of 0.31mm. No decoupling capacitors are required in typical applications as long as no DC is applied to any RF port.

Table 1: Ordering Information

Type	Package	Marking
BGS12PL6	TSLP-6-4	P

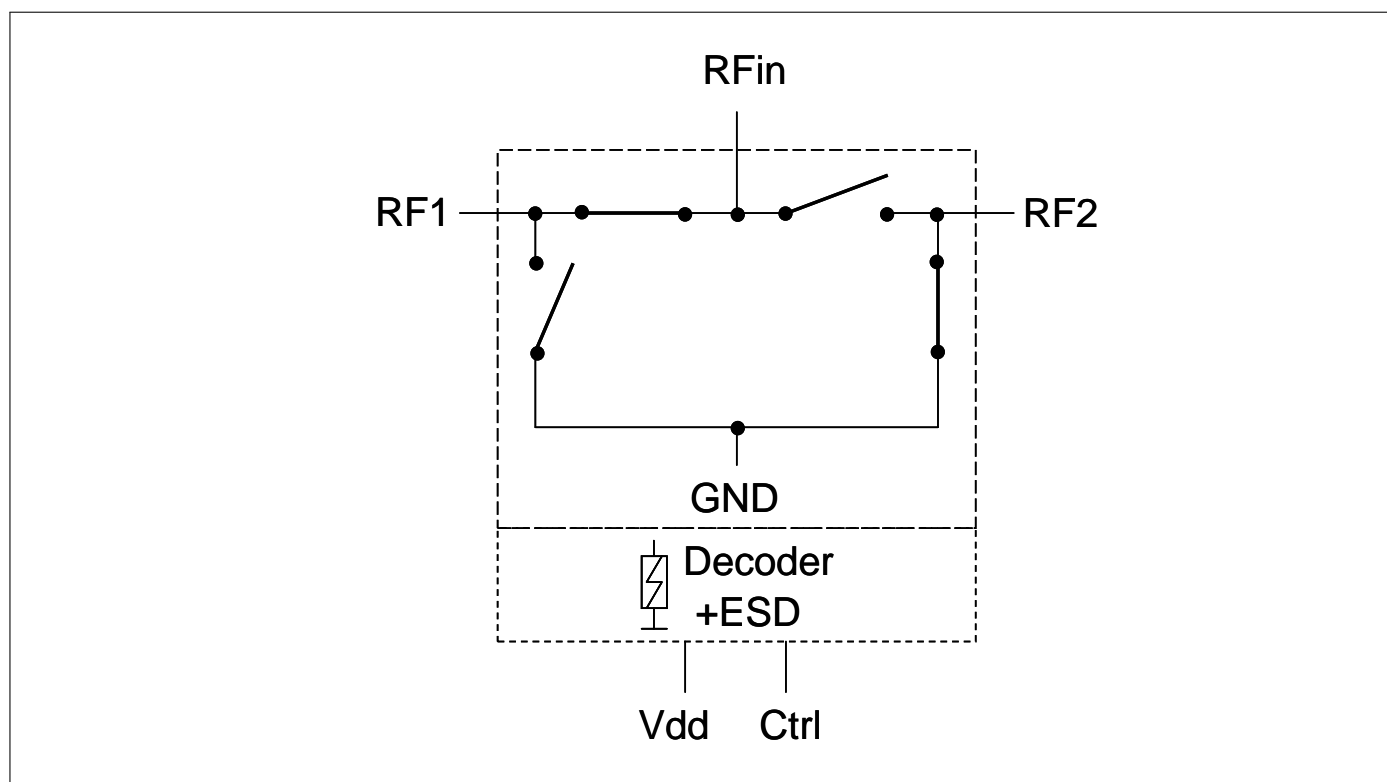

Figure 1: BGS12PL6 Block Diagram

Table 2: Truth Table

Switched Paths	Ctrl
RFin - RF1	0
RFin - RF2	1

3 Maximum Ratings

Table 3: Maximum Ratings at $T_A = 25\text{ °C}$, unless otherwise specified

Parameter	Symbol	Values			Unit	Note / Test Condition
		Min.	Typ.	Max.		
Supply Voltage	V_{dd}	-0.5	–	5.5	V	–
Control Voltage	V_{Ctrl}	-0.3	–	3.6	V	–
Storage Temperature Range	T_{STG}	-55	–	150	°C	–
RF Input Power at all RF Ports	P_{RF}	–	–	36	dBm	CW
Junction Temperature	T_j	–	–	125	°C	–
ESD Capability						
Human Body Model ¹⁾	V_{ESD_HBM}	–1	–	+1	kV	–
ESD Capability RFin Port ²⁾	V_{ESD_RFin}	–8	–	+8	kV	RFin versus GND, with 27 nH shunt inductor

¹⁾ Human Body Model ANSI/ESDA/JEDEC JS-001-2012 ($R = 1.5\text{ k}\Omega$, $C = 100\text{ pF}$).

²⁾ IEC 61000-4-2 ($R = 330\ \Omega$, $C = 150\text{ pF}$), contact discharge.

Attention:

Stresses above the max. values listed here may cause permanent damage to the device. Exposure to absolute maximum rating conditions for extended periods may affect device reliability. Maximum ratings are absolute ratings; exceeding only one of these values may cause irreversible damage to the integrated circuit.

4 Operation Ranges

Table 4: Operation Ranges

Parameter	Symbol	Values			Unit	Note / Test Condition
		Min.	Typ.	Max.		
Ambient Temperature	T_A	-40	25	85	°C	–
RF Frequency	f	0.03	–	4	GHz	–
Supply Voltage	V_{dd}	2.4	–	3.6	V	–
Control Voltage Low	V_{Ctrl_L}	-0.3	–	0.3	V	–
Control Voltage High	V_{Ctrl_H}	1.4	–	V_{dd}	V	–

Table 5: RF Input Power

Parameter	Symbol	Values			Unit	Note / Test Condition
		Min.	Typ.	Max.		
RF Input Power (50 Ω)	P_{In}	–	–	35	dBm	–

5 RF Characteristics

Table 6: RF Characteristics

Test Conditions (unless otherwise specified):

- Terminating port impedance: $Z_0 = 50 \Omega$
- Temperature range: $T_A = -40 \dots +85 \text{ }^\circ\text{C}$
- Supply voltage: $V_{dd} = 2.4 \dots 3.6 \text{ V}$
- Input power: $P_{IN} = 0 \text{ dBm}$

Parameter	Symbol	Values			Unit	Note / Test Condition
		Min.	Typ.	Max.		
Insertion Loss						
All RF Ports	IL	0.27	0.36	0.55	dB	699-915 MHz
		0.36	0.46	0.70	dB	1710-1910 MHz
		0.46	0.56	0.85	dB	2170-2690 MHz
		0.61	0.77	1.15	dB	3800 MHz
Insertion Loss¹						
All RF Ports	IL	0.33	0.36	0.40	dB	699-915 MHz
		0.40	0.46	0.50	dB	1710-1910 MHz
		0.52	0.56	0.65	dB	2170-2690 MHz
		0.65	0.77	0.90	dB	3800 MHz
Return Loss						
All RF Ports	RL	20	25	35	dB	699-915 MHz
		16	20	28	dB	1710-1910 MHz
		14	18	27	dB	2170-2690 MHz
		12	15	20	dB	3800 MHz
Isolation						
RFIn to RF1/RF2 Port	$ISO_{RFIn-RFx}$	34	37	–	dB	699-915 MHz
		27	30	–	dB	1710-1910 MHz
		23	27	–	dB	2170-2690 MHz
		19	22	–	dB	3800 MHz
RF1 to RF2 Port	$ISO_{Port-Port}$	45	50	–	dB	699-915 MHz
		34	36	–	dB	1710-1910 MHz
		28	31	–	dB	2170-2690 MHz
		24	27	–	dB	3800 MHz
P0.1 dB Compression Point						
All RF Ports	$P_{0.1dB}$	–	38	–	dBm	699 - 2700 MHz

¹ $T_A = +25 \text{ }^\circ\text{C}$, $V_{dd} = 3 \text{ V}$

Parameter	Symbol	Values			Unit	Note / Test Condition
		Min.	Typ.	Max.		
Harmonic Generation up to 12.75 GHz¹						
All RF Ports, 2 nd Harmonic	P_{Harm}	-90	-80	-70	dBc	$f = 824 \text{ MHz}$, $P_{in} = 27.5 \text{ dBm}$, 50Ω, 50 % duty cycle
All RF Ports, 3 rd Harmonic		-100	-90	-80	dBc	
Intermodulation Distortion in Rx Band^{1,2}						
IMD2, Low	$IMD2_{Low}$	–	-110	-100	dBm	Tx = 15 dBm, Interferer = -15 dBm, 50Ω
IMD3	$IMD3$	–	-110	-100	dBm	
IMD2, High	$IMD2_{High}$	–	-110	-100	dBm	
Switching Time and Current Consumption						
RF Rise Time	$t_{10\%-90\%}$	–	0.55	1.5	μs	10% - 90% of RF Signal
Ctrl to RF Time	$t_{Ctrl-RF}$	–	1.4	3	μs	50% of Ctrl Signal to 90% of RF Signal
Supply Current	I_{dd}	80	200	350	μA	–
Control Current	I_{Ctrl}	–	1	10	μA	–

Note: All electrical characteristics are measured with all RF ports terminated by 50 Ω loads.

¹ $T_A = +25^\circ \text{C}$, $V_{dd} = 3 \text{ V}$

² With external shunt L

6 Pin Description

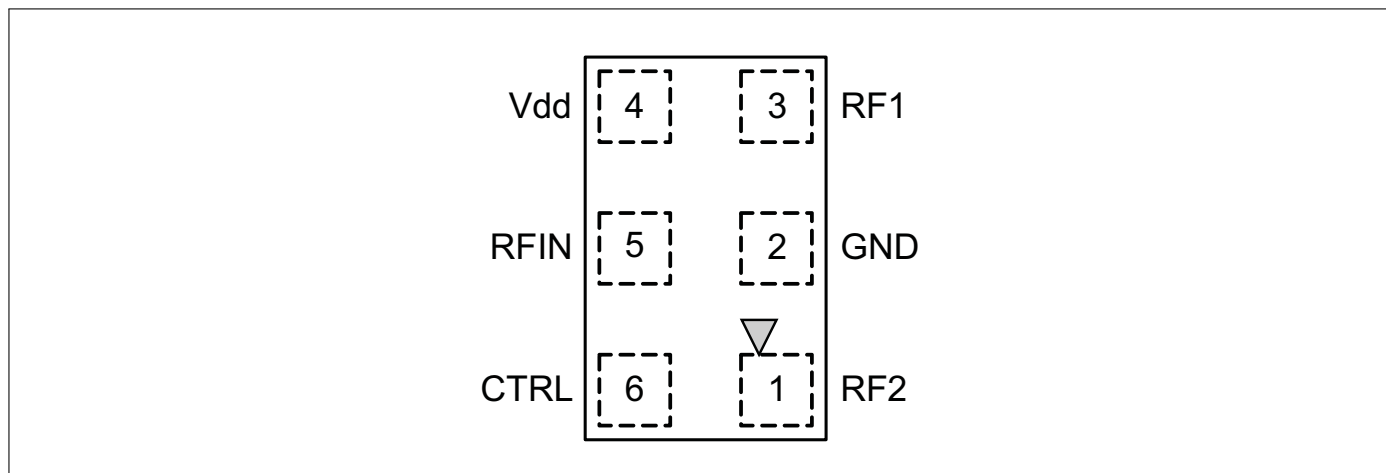

Figure 2: Pin Configuration

Table 7: Pin Description

Pin No.	Name	Pin Type	Buffer Type	Function
1	RF2	I/O		RF Port 2
2	GND	GND		Ground
3	RF1	I/O		RF Port 1
4	Vdd	PWR		Supply Voltage
5	RFIN	I/O		RF Port In
6	CTRL	I		Control Pin

7 Package Information

Table 8: Mechanical Data

Parameter	Symbol	Value	Unit
X-Dimension	<i>X</i>	0.7 ± 0.05	mm
Y-Dimension	<i>Y</i>	1.1 ± 0.05	mm
Size	<i>Size</i>	0.77	mm ²
Height	<i>H</i>	0.31+0.01/-0.02	mm

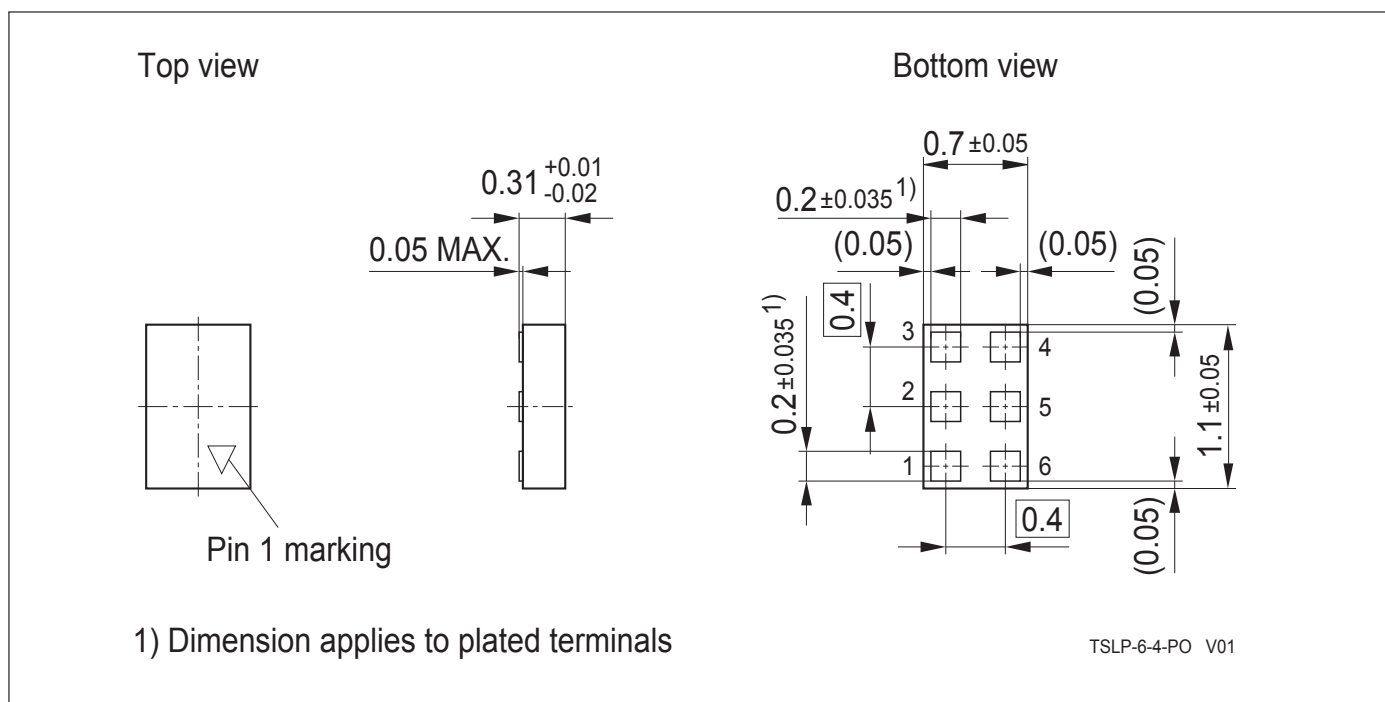

Figure 3: Package Outline

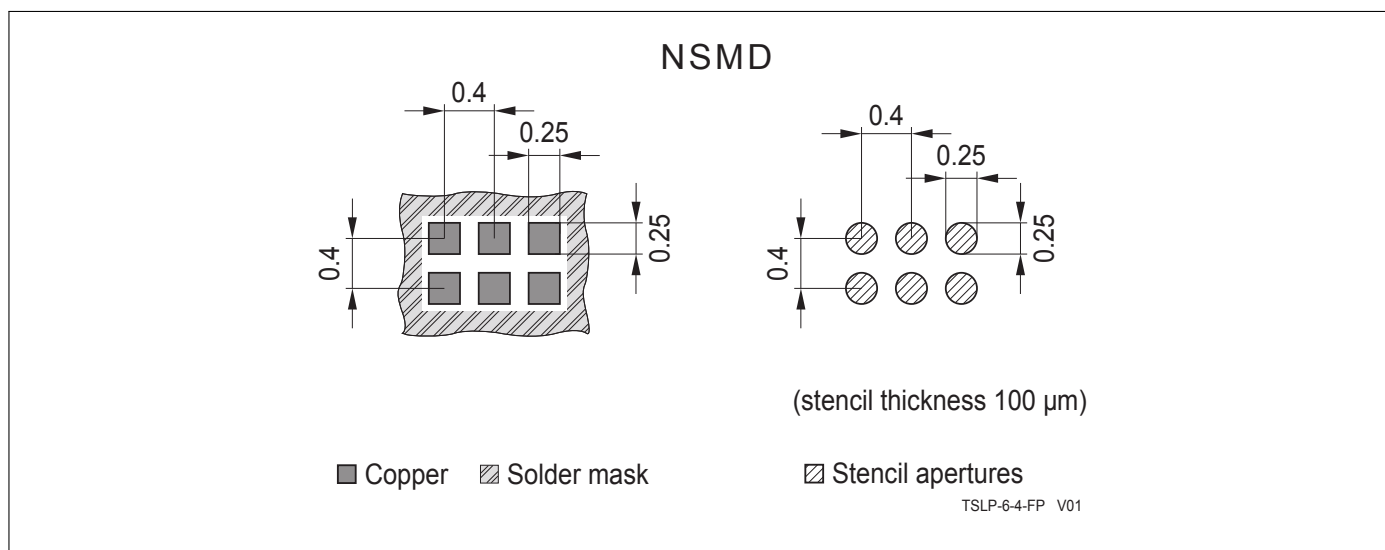

Figure 4: Footprint

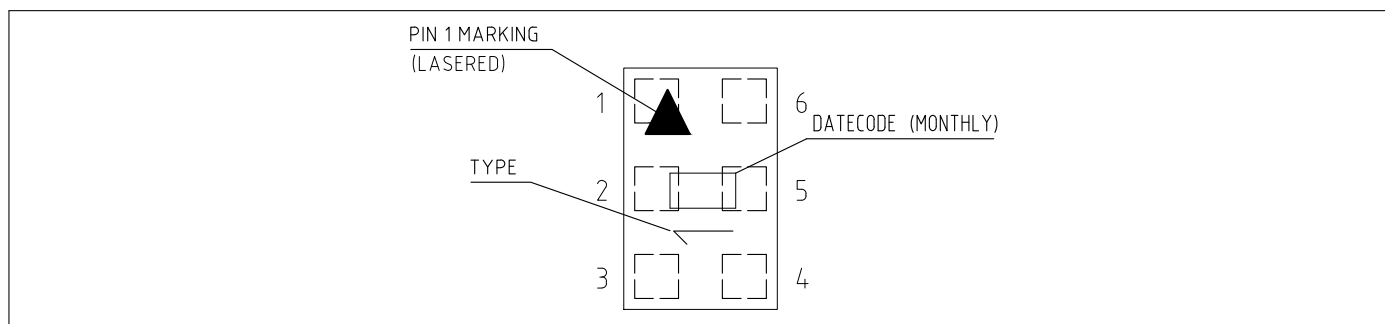

Figure 5: Pin 1 Marking (top view)

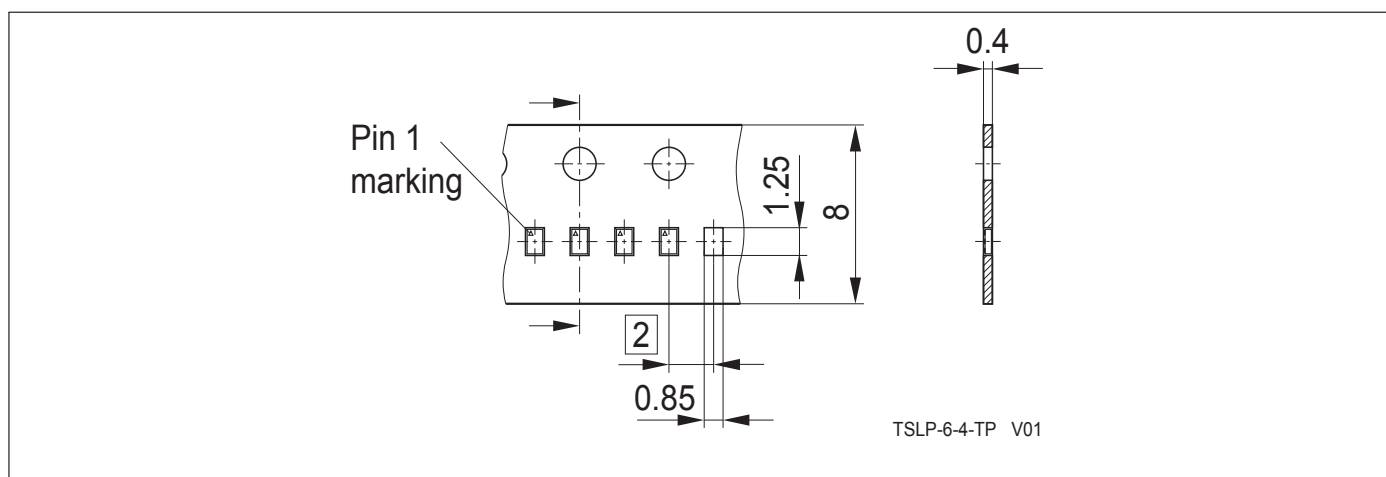

Figure 6: Tape Drawing for TSLP-6-4