

SGM8199

Voltage Output, High or Low Side Measurement, Bi-Directional Current Shunt Monitor

GENERAL DESCRIPTION

The SGM8199 series are voltage output current shunt monitors which can sense drop across shunt at common mode voltages from -0.1V to 26V, independent of the supply voltage. Three fixed gains are available: 20V/V, 50V/V and 100V/V. The low offset enables current sensing with maximum drops across the shunt as low as 10mV full-scale.

These devices operate from a single 2.7V to 26V power supply, drawing a typical 85µA of supply current.

The SGM8199 series are available in Green SC70-6 package. They are specified over the extended -40°C to +125°C temperature range.

APPLICATIONS

- Notebook Computers
- Cell Phones
- Telecom Equipment
- Power Managements
- Battery Chargers
- Welding Equipment

FEATURES

- **Wide Common Mode Range: -0.1V to 26V**
- **Input Offset Voltage**
SGM8199A0: 600µV ($V_{CM} = 12V, MAX$)
SGM8199A1: 350µV ($V_{CM} = 12V, MAX$)
SGM8199A2: 250µV ($V_{CM} = 12V, MAX$)
(Enables Shunt Drops of 10mV Full-Scale)
- **Gain Error (Maximum Over Temperature)**
SGM8199A0: ±0.7%
SGM8199A1: ±0.4%
SGM8199A2: ±0.4%
- **Choice of Gains:**
SGM8199A0 Gain: 20V/V
SGM8199A1 Gain: 50V/V
SGM8199A2 Gain: 100V/V
- **Quiescent Current: 85µA (TYP)**
- **-40°C to +125°C Operating Temperature Range**
- **Available in Green SC70-6 Package**

TYPICAL APPLICATION

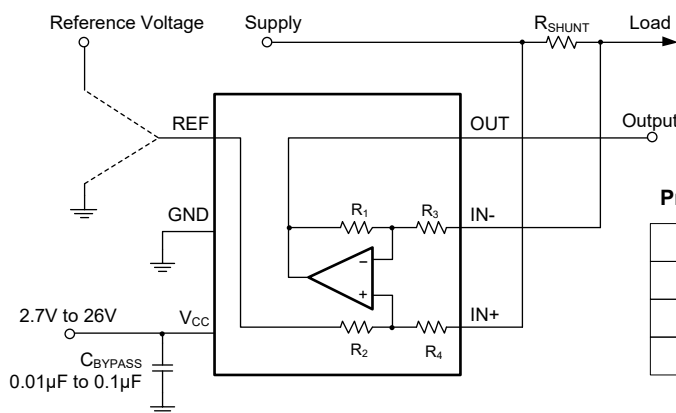

Product Family Table

PRODUCT	GAIN	R ₁ AND R ₂	R ₃ AND R ₄
SGM8199A0	20	400kΩ	20kΩ
SGM8199A1	50	1MΩ	20kΩ
SGM8199A2	100	1MΩ	10kΩ

Figure 1. Typical Application Circuit

Voltage Output, High or Low Side Measurement, Bi-Directional Current Shunt Monitor

SGM8199

PACKAGE/ORDERING INFORMATION

MODEL	PACKAGE DESCRIPTION	GAIN	SPECIFIED TEMPERATURE RANGE	ORDERING NUMBER	PACKAGE MARKING	PACKING OPTION
SGM8199A0	SC70-6	20V/V	-40°C to +125°C	SGM8199A0XC6G/TR	M91XX	Tape and Reel, 3000
SGM8199A1	SC70-6	50V/V	-40°C to +125°C	SGM8199A1XC6G/TR	GS2XX	Tape and Reel, 3000
SGM8199A2	SC70-6	100V/V	-40°C to +125°C	SGM8199A2XC6G/TR	M93XX	Tape and Reel, 3000

MARKING INFORMATION

NOTE: XX = Date Code.

SC70-6

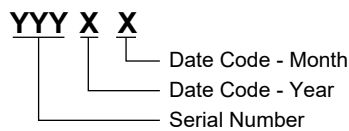

Green (RoHS & HSF): SG Micro Corp defines "Green" to mean Pb-Free (RoHS compatible) and free of halogen substances. If you have additional comments or questions, please contact your SGMICRO representative directly.

ABSOLUTE MAXIMUM RATINGS

Supply Voltage.....	28V
V _{IN} Differential.....	±28V
Input Common Mode Voltage Range.....	GND - 0.3V to 28V
Input Current into All Pins	5mA
Junction Temperature	+150°C
Storage Temperature Range.....	-65°C to +150°C
Lead Temperature (Soldering, 10s)	+260°C
ESD Susceptibility	
HBM.....	3000V
MM.....	200V
CDM	2000V

RECOMMENDED OPERATING CONDITIONS

Operating Temperature Range	-40°C to +125°C
-----------------------------------	-----------------

PIN CONFIGURATION

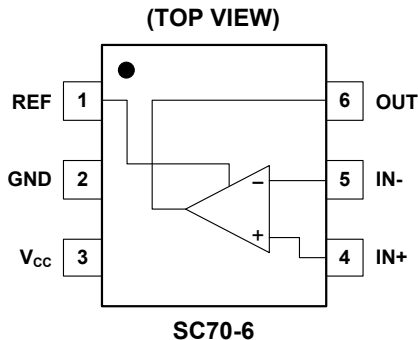

OVERSTRESS CAUTION

Stresses beyond those listed in Absolute Maximum Ratings may cause permanent damage to the device. Exposure to absolute maximum rating conditions for extended periods may affect reliability. Functional operation of the device at any conditions beyond those indicated in the Recommended Operating Conditions section is not implied.

ESD SENSITIVITY CAUTION

This integrated circuit can be damaged by ESD if you don't pay attention to ESD protection. SGMICRO recommends that all integrated circuits be handled with appropriate precautions. Failure to observe proper handling and installation procedures can cause damage. ESD damage can range from subtle performance degradation to complete device failure. Precision integrated circuits may be more susceptible to damage because very small parametric changes could cause the device not to meet its published specifications.

DISCLAIMER

SG Micro Corp reserves the right to make any change in circuit design, or specifications without prior notice.

Voltage Output, High or Low Side Measurement, Bi-Directional Current Shunt Monitor

SGM8199

ELECTRICAL CHARACTERISTICS

(At $T_A = +25^\circ\text{C}$, Full = -40°C to $+125^\circ\text{C}$, $V_{CC} = 2.7\text{V}$ to 26V , $V_{IN+} = 12\text{V}$, $V_{SENSE} = V_{IN+} - V_{IN-}$, and $V_{REF} = V_{CC}/2$, unless otherwise noted.)

PARAMETER	CONDITIONS		TEMP	MIN	TYP	MAX	UNITS
INPUT CHARACTERISTICS							
Input Offset Voltage, RTI ⁽¹⁾ (V_{OS})	$V_{CM} = -0.1\text{V}$ to 2V , $V_{SENSE} = 0\text{mV}$	SGM8199A0	$+25^\circ\text{C}$		270	1420	μV
	$V_{CM} = 2\text{V}$ to 26V , $V_{SENSE} = 0\text{mV}$				260	600	
	$V_{CM} = -0.1\text{V}$ to 2V , $V_{SENSE} = 0\text{mV}$	SGM8199A1			150	720	
	$V_{CM} = 2\text{V}$ to 26V , $V_{SENSE} = 0\text{mV}$				150	350	
	$V_{CM} = -0.1\text{V}$ to 2V , $V_{SENSE} = 0\text{mV}$	SGM8199A2			80	750	
	$V_{CM} = 2\text{V}$ to 26V , $V_{SENSE} = 0\text{mV}$				80	250	
Input Offset Voltage Drift ($\Delta V_{OS}/\Delta T$)			Full		1		$\mu\text{V}/^\circ\text{C}$
Input Bias Current (I_b)	$V_{SENSE} = 0\text{mV}$	SGM8199A0	$+25^\circ\text{C}$		30		μA
		SGM8199A1/ SGM8199A2			16		
Input Offset Current (I_{OS})	$V_{SENSE} = 0\text{mV}$	SGM8199A0	$+25^\circ\text{C}$		35		nA
		SGM8199A1/ SGM8199A2			25		
Input Common Mode Voltage Range (V_{CM})			Full	-0.1		26	V
Common Mode Rejection Ratio (CMRR)	$V_{CM} = -0.1\text{V}$ to 26V , $V_{SENSE} = 0\text{mV}$	SGM8199A0	Full		85	97	dB
	$V_{CM} = 2\text{V}$ to 26V , $V_{SENSE} = 0\text{mV}$				81	93	
	$V_{CM} = -0.1\text{V}$ to 26V , $V_{SENSE} = 0\text{mV}$	SGM8199A1			85	104	
	$V_{CM} = 2\text{V}$ to 26V , $V_{SENSE} = 0\text{mV}$				87	100	
	$V_{CM} = -0.1\text{V}$ to 26V , $V_{SENSE} = 0\text{mV}$	SGM8199A2			90	108	
	$V_{CM} = 2\text{V}$ to 26V , $V_{SENSE} = 0\text{mV}$				91	106	
OUTPUT CHARACTERISTICS							
Gain (G)			$+25^\circ\text{C}$		20		V/V
					50		
					100		
Gain Error	$V_{SENSE} = -5\text{mV}$ to 5mV	SGM8199A0	Full		0.20	0.7	%
		SGM8199A1			0.02	0.4	
		SGM8199A2			0.05	0.4	
Gain Temperature Coefficient			Full		10		$\text{ppm}/^\circ\text{C}$
Nonlinearity Error	$V_{SENSE} = -5\text{mV}$ to 5mV		$+25^\circ\text{C}$		0.01		%
Maximum Capacitive Load	No sustained oscillation		$+25^\circ\text{C}$		1		nF
Output Voltage Swing from Rail	V_{OH}	$V_{CC} = 26\text{V}$, $R_L = 10\text{k}\Omega$ to $V_{CC}/2$	Full		140	380	mV
	V_{OL}				85	300	

NOTE:

1. RTI = Referred-to-input.

Voltage Output, High or Low Side Measurement, Bi-Directional Current Shunt Monitor

SGM8199

ELECTRICAL CHARACTERISTICS (continued)

(At $T_A = +25^\circ\text{C}$, Full = -40°C to $+125^\circ\text{C}$, $V_{CC} = 2.7\text{V}$ to 26V , $V_{IN+} = 12\text{V}$, $V_{SENSE} = V_{IN+} - V_{IN-}$, and $V_{REF} = V_{CC}/2$, unless otherwise noted.)

PARAMETER	CONDITIONS	TEMP	MIN	TYP	MAX	UNITS
DYNAMIC PERFORMANCE						
-3dB Bandwidth	$V_{CC} = 5\text{V}$, $R_L = 10\text{k}\Omega$, $C_L = 10\text{pF}$	SGM8199A0	+25°C	74		kHz
		SGM8199A1		80		
		SGM8199A2		68		
Slew Rate (SR)	$f = 1\text{kHz}$, $R_L = 10\text{k}\Omega$, $V_{OUT} = 1V_{P-P}$	SGM8199A0	+25°C	0.42		V/ μs
	$f = 1\text{kHz}$, $R_L = 10\text{k}\Omega$, $V_{OUT} = 2V_{P-P}$	SGM8199A0		0.42		
	$f = 1\text{kHz}$, $R_L = 10\text{k}\Omega$, $V_{OUT} = 1V_{P-P}$	SGM8199A1		0.15		
	$f = 1\text{kHz}$, $R_L = 10\text{k}\Omega$, $V_{OUT} = 2V_{P-P}$	SGM8199A1		0.35		
	$f = 1\text{kHz}$, $R_L = 10\text{k}\Omega$, $V_{OUT} = 1V_{P-P}$	SGM8199A2		0.12		
	$f = 1\text{kHz}$, $R_L = 10\text{k}\Omega$, $V_{OUT} = 2V_{P-P}$	SGM8199A2		0.3		
NOISE, RTI ⁽¹⁾						
Voltage Noise Density (e_n)	$f = 1\text{kHz}$	SGM8199A0	+25°C	48		nV/ $\sqrt{\text{Hz}}$
		SGM8199A1		50		
		SGM8199A2		35		
POWER SUPPLY						
Operating Voltage Range (V_{CC})		Full	2.7		26	V
Quiescent Current (I_Q)	$V_{CC} = 26\text{V}$, $V_{SENSE} = 0\text{mV}$	+25°C		85	120	μA
		Full			130	
Power Supply Rejection Ratio (PSRR)	$V_{CC} = 2.7\text{V}$ to 26V , $V_{SENSE} = 0\text{mV}$	SGM8199A0	+25°C	100		dB
		SGM8199A1/		105		
		SGM8199A2				

NOTE:

1. RTI = Referred-to-input.

TYPICAL PERFORMANCE CHARACTERISTICS

Performance measured with the SGM8199A1 at $T_A = +25^\circ\text{C}$, $V_{CC} = 5\text{V}$, $\text{GND} = 0\text{V}$, $V_{IN+} = 12\text{V}$, $V_{SENSE} = V_{IN+} - V_{IN-}$ and $V_{REF} = V_{CC}/2$, unless otherwise noted.

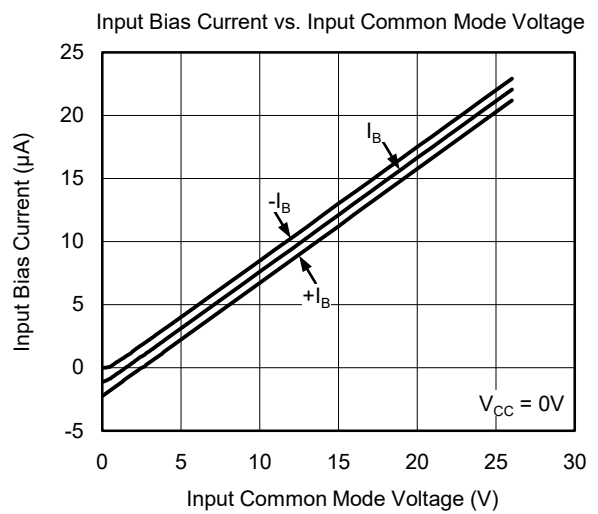
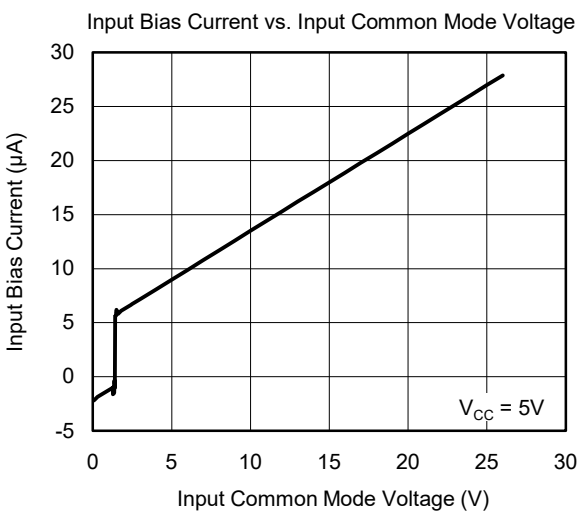
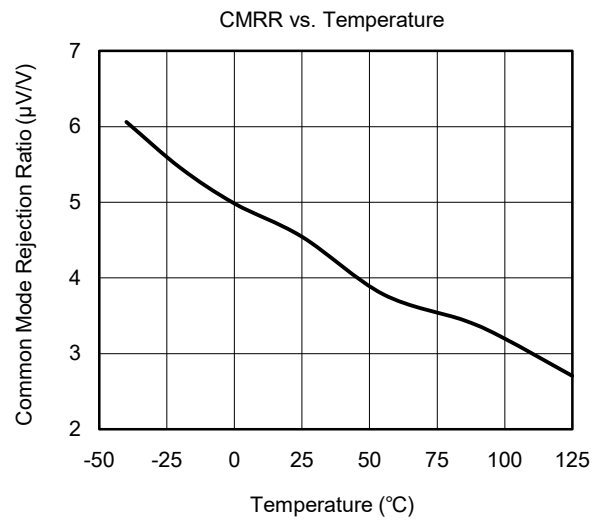
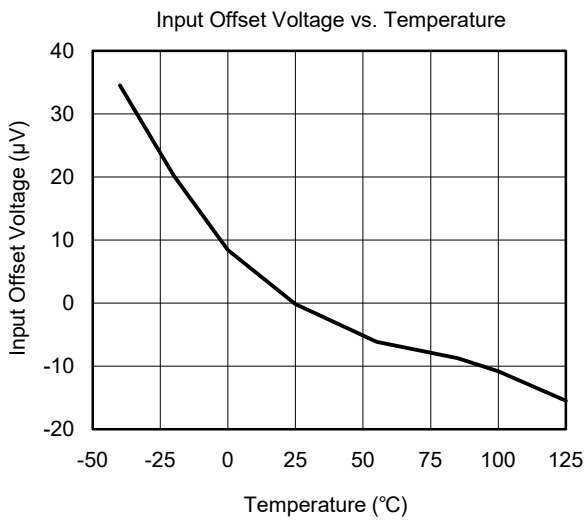
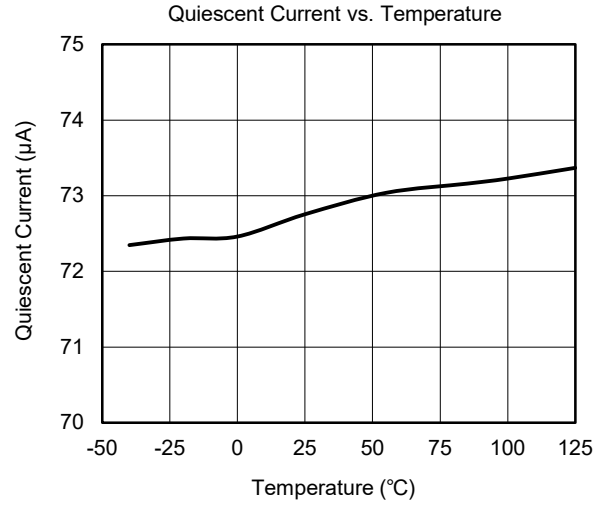
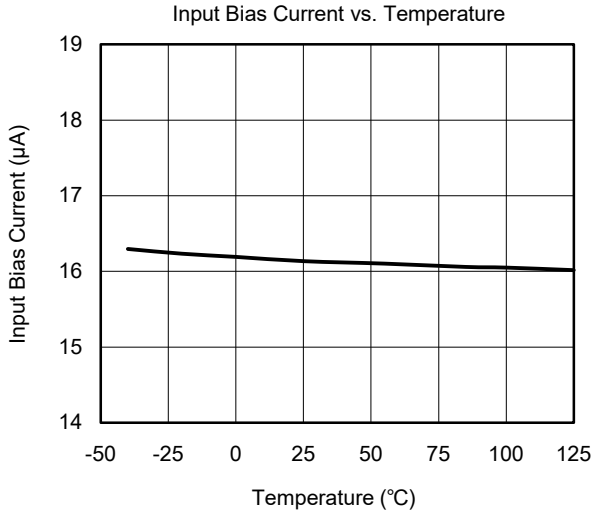

SGM8199 Voltage Output, High or Low Side Measurement, Bi-Directional Current Shunt Monitor

TYPICAL PERFORMANCE CHARACTERISTICS (continued)

Performance measured with the SGM8199A1 at $T_A = +25^\circ\text{C}$, $V_{CC} = 5\text{V}$, $\text{GND} = 0\text{V}$, $V_{IN+} = 12\text{V}$, $V_{SENSE} = V_{IN+} - V_{IN-}$ and $V_{REF} = V_{CC}/2$, unless otherwise noted.

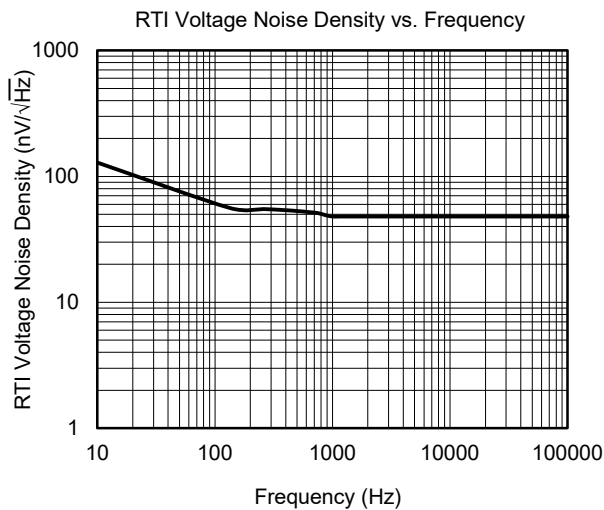
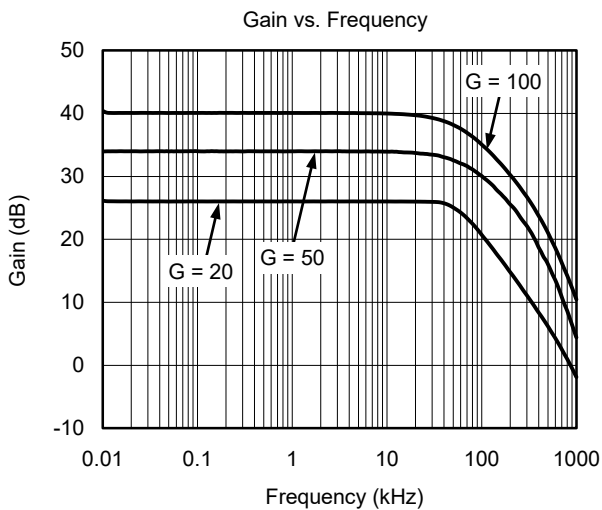
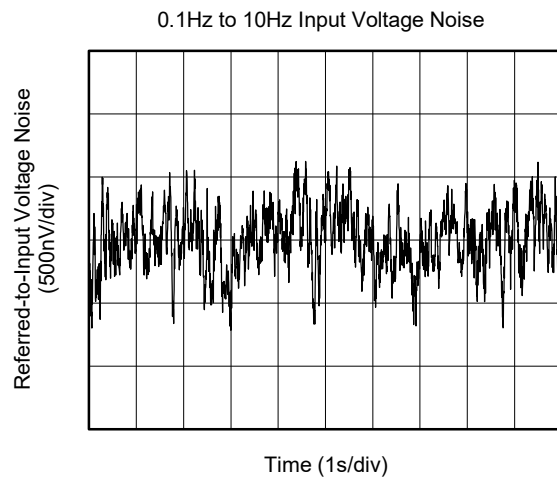
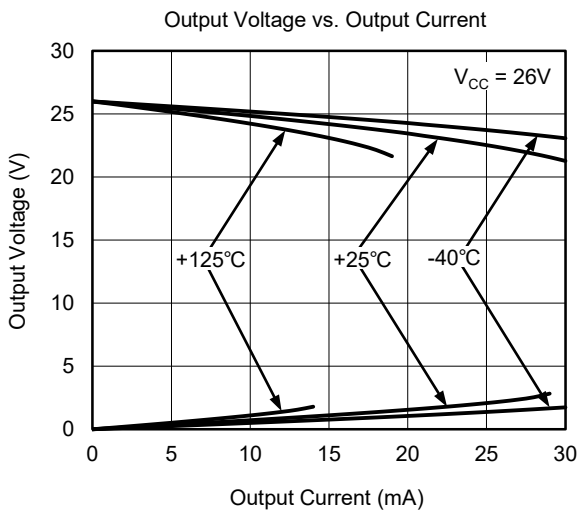
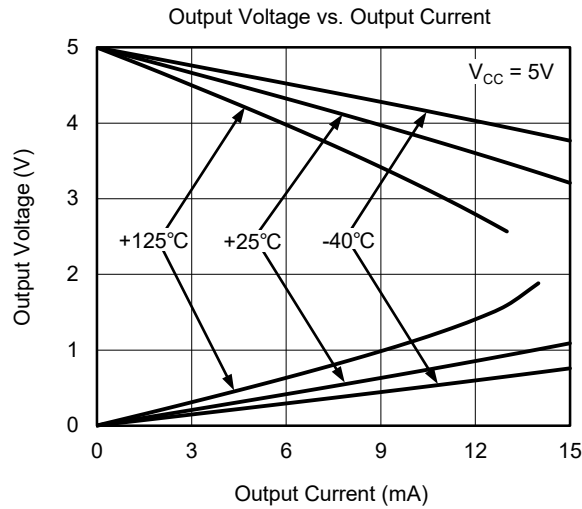
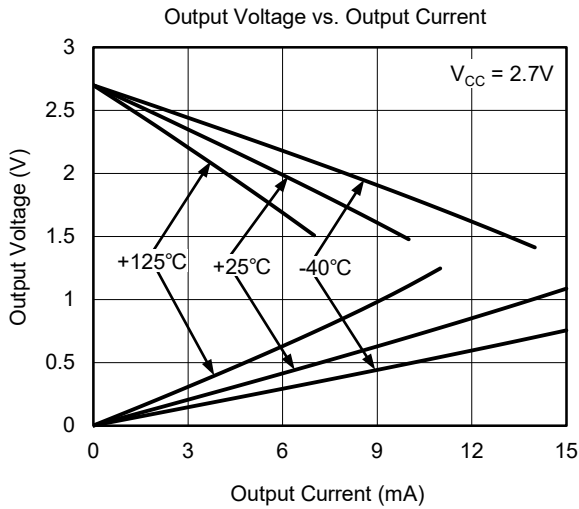

TYPICAL PERFORMANCE CHARACTERISTICS (continued)

Performance measured with the SGM8199A1 at $T_A = +25^\circ\text{C}$, $V_{CC} = 5\text{V}$, $\text{GND} = 0\text{V}$, $V_{IN+} = 12\text{V}$, $V_{SENSE} = V_{IN+} - V_{IN-}$ and $V_{REF} = V_{CC}/2$, unless otherwise noted.

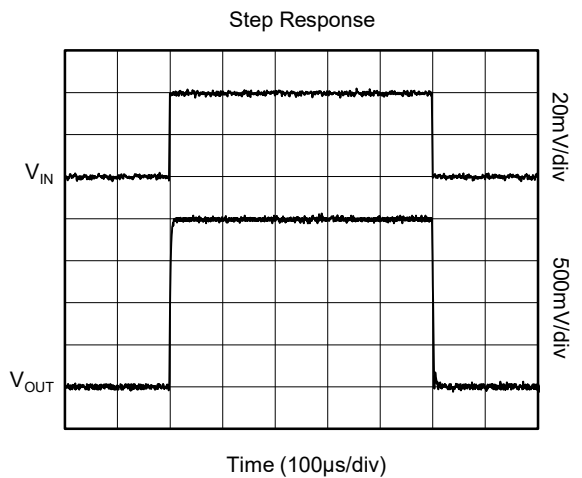
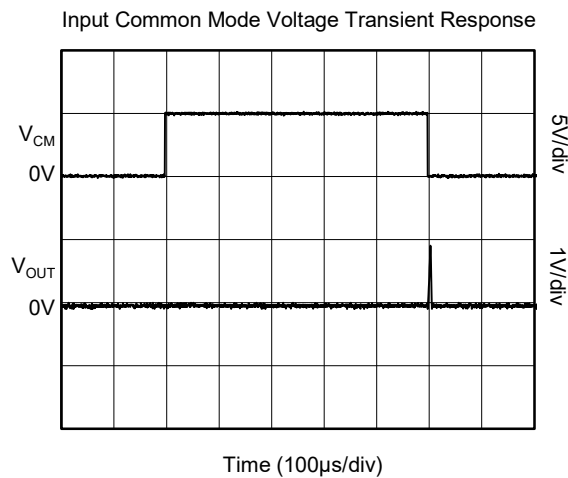
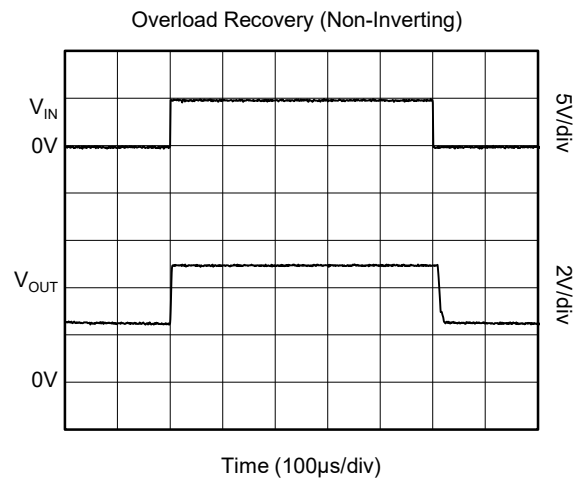
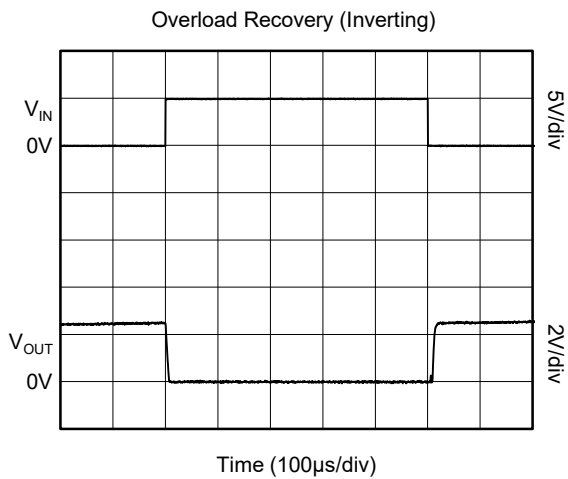
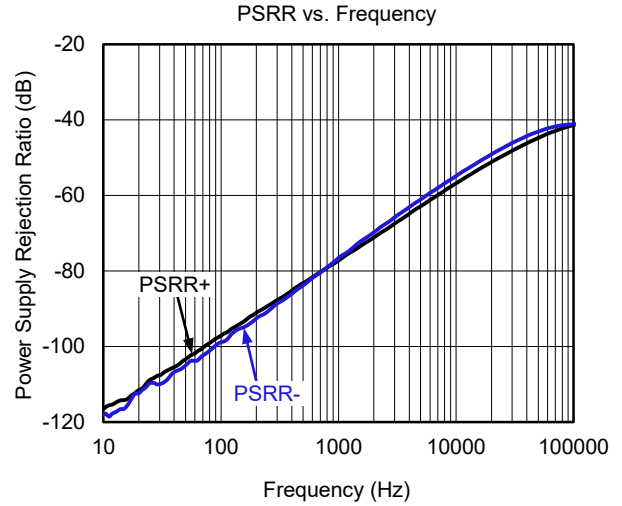
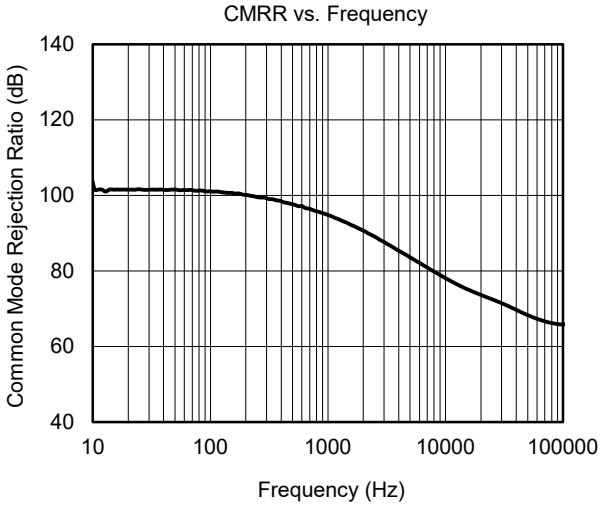

TYPICAL PERFORMANCE CHARACTERISTICS (continued)

Performance measured with the SGM8199A1 at $T_A = +25^\circ\text{C}$, $V_{CC} = 5\text{V}$, $\text{GND} = 0\text{V}$, $V_{IN+} = 12\text{V}$, $V_{SENSE} = V_{IN+} - V_{IN-}$ and $V_{REF} = V_{CC}/2$, unless otherwise noted.

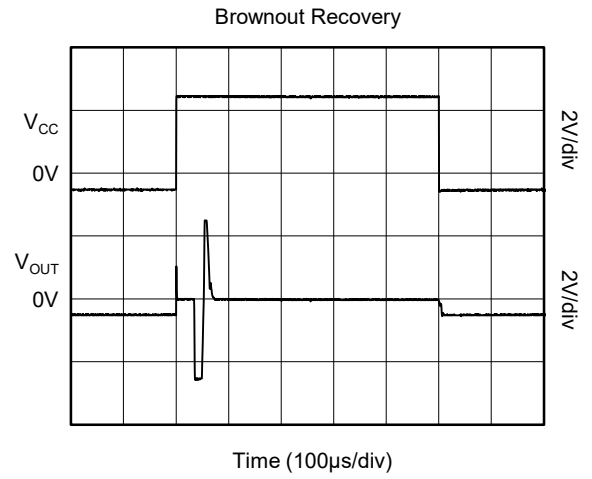
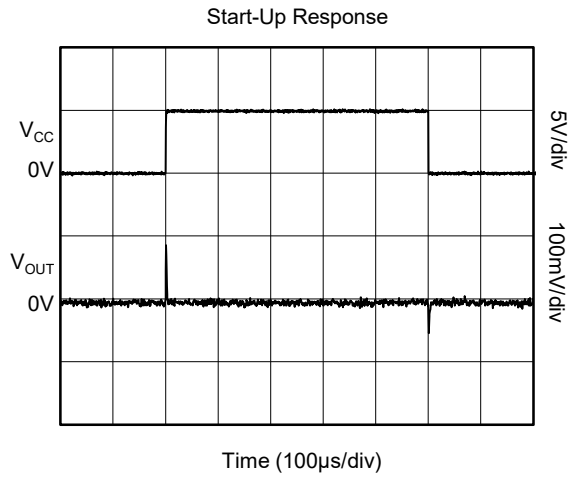

APPLICATION INFORMATION

Basic Connection

Figure 1 shows the basic connection for the SGM8199. The input pins, IN+ and IN-, should be connected as closely as possible to the shunt resistor to minimize any resistance in series with the shunt resistance.

Power supply bypass capacitors are required for stability. Applications with noisy or high-impedance power supplies may require additional decoupling capacitors to reject power supply noise. Connect bypass capacitors close to the device pins.

Power Supply

The input circuitry of the SGM8199 can accurately measure beyond its power supply voltage, V_{CC} . For example, the V_{CC} power supply can be 5V, whereas the load power supply voltage can be as high as 26V. However, the output voltage range of the OUT terminal is limited by the voltages on the power supply pin. Note also that the SGM8199 can withstand the full -0.1V to 26V range in the input pins, regardless of whether the device has power applied or not.

Selecting R_{SHUNT}

The SGM8199 series of current-shunt monitors give high accuracy at a full-scale range on the order of 10mV. This accuracy reduces shunt dissipation by an order of magnitude with many additional benefits.

Alternatively, there are applications that must measure current over a wide dynamic range that can take advantage of the low offset on the low end of the measurement. Most often, these applications can use gain of 20, 50 or 100 to accommodate larger shunt drops on the upper end of the scale. For instance, an SGM8199A1 operating on a 3.3V supply could easily handle a full-scale shunt drop of 60mV, with only 350 μ V of offset.

Unidirectional Operation

Unidirectional operation allows the SGM8199 to measure currents through a resistive shunt in one direction. The most frequent case of unidirectional operation sets the output at ground by connecting the REF pin to ground. In unidirectional applications where the highest possible accuracy is desirable at very low inputs, bias the REF pin to a convenient value above 300mV to get the device output swing into the linear range for zero inputs.

A less frequent case of unipolar output biasing is to bias the output by connecting the REF pin to the supply; in this case, the quiescent output for zero input is at quiescent supply. This configuration would only respond to negative currents (inverted voltage polarity at the device input).

Bi-Directional Operation

Bi-directional operation allows the SGM8199 to measure currents through a resistive shunt in two directions. In this case, the output can be set anywhere within the limits of what the reference inputs allow (that is, between 0V to V_{CC}). Typically, it is set at half-scale for equal range in both directions. In some cases, however, it is set at a voltage other than half-scale when the bi-directional current is nonsymmetrical.

The quiescent output voltage is set by applying voltage to the reference input. Under zero differential input conditions the output assumes the same voltage that is applied to the reference input.

Input Filtering

An obvious and straightforward filtering location is at the device output. However, this location negates the advantage of the low output impedance of the internal buffer. The only other filtering option is at the device input pins. Figure 2 shows a filter placed at the inputs pins.

APPLICATION INFORMATION (continued)

The addition of external series resistance, however, creates an additional error in the measurement so the value of these series resistors should be kept to 10Ω or less if possible to reduce impact to accuracy. The internal bias network shown in Figure 2 present at the input pins creates a mismatch in input bias currents when a differential voltage is applied between the input pins. If additional external series filter resistors are added to the circuit, the mismatch in bias currents results in a mismatch of voltage drops across the filter resistors. This mismatch creates a differential error voltage that subtracts from the voltage developed at the shunt resistor. This error results in a voltage at the device input pins that is different than the voltage developed across the shunt resistor. Without the additional series resistance, the mismatch in input bias currents has little effect on device operation.

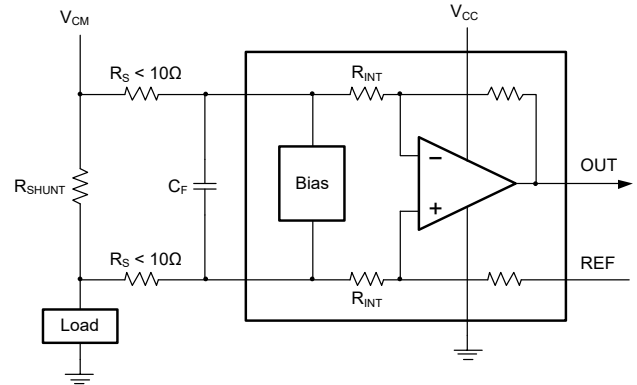
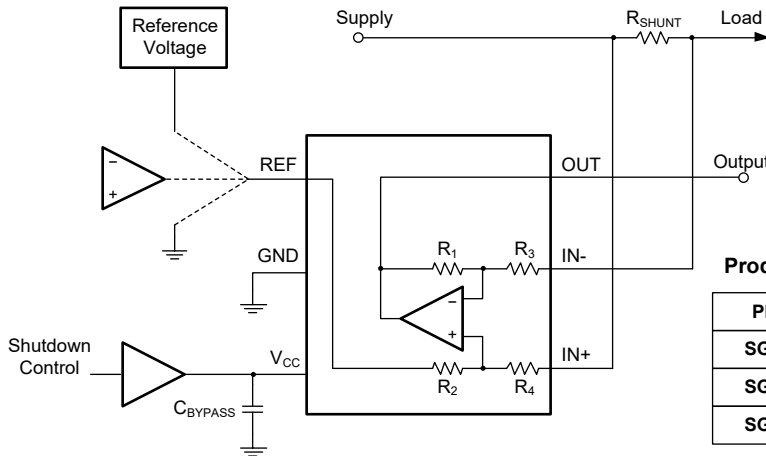

Figure 2. Filter at Input Pins

Shutting Down the SGM8199 Series

While the SGM8199 series do not have a shutdown pin, the low power consumption allows powering from the output of a logic gate or transistor switch that can turn on and turn off the SGM8199 power supply quiescent current.

However, in current shunt monitoring applications, there is also a concern for how much current is drained from the shunt circuit in shutdown conditions. Evaluating this current drain involves considering the simplified schematic of the SGM8199 in shutdown mode shown in Figure 3.



Product Family Table

PRODUCT	GAIN	R ₁ AND R ₂	R ₃ AND R ₄
SGM8199A0	20	400kΩ	20kΩ
SGM8199A1	50	1MΩ	20kΩ
SGM8199A2	100	1MΩ	10kΩ

NOTE: 400kΩ or 1MΩ path from shunt inputs to reference and SGM8199 outputs.

Figure 3. Basic Circuit for Shutting Down SGM8199 with Grounded Reference

APPLICATION INFORMATION (continued)

REF Input Impedance Effects

As with any difference amplifier, the SGM8199 series common mode rejection ratio is affected by any impedance present at the REF input. This concern is not a problem when the REF pin is connected directly to most references or power supplies. When using resistive dividers from the power supply or a reference voltage, the REF pin should be buffered by an operational amplifier.

In systems where the SGM8199 output can be sensed differentially, such as by a differential input analog-to-digital converter (ADC) or by using two separate ADC inputs, the effects of external impedance on the REF input can be cancelled. Figure 4 depicts a method of taking the output from the SGM8199 by using the REF pin as a reference.

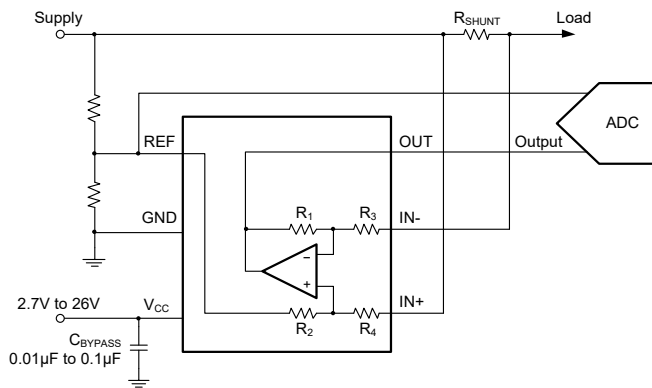

Figure 4. Sensing SGM8199 to Cancel Effects of Impedance on the REF Input

Using the SGM8199 with Common Mode Transients above 26V

With a small amount of additional circuitry, the SGM8199 series can be used in circuits subject to transients higher than 26V, such as automotive applications. Use only Zener diode or Zener-type transient absorbers (sometimes referred to as Transzorb); any other type of transient absorber has an unacceptable time delay. Start by adding a pair of resistors as shown in Figure 5 as working impedance for the Zener. It is desirable to keep these resistors as small as possible, most often around 10Ω. Larger values can be used with an effect on gain that is discussed in the section on input filtering. Because this circuit limits only short-term transients, many applications are satisfied with a 10Ω resistor along with conventional

Zener diodes of the lowest power rating that can be found. This combination uses the least amount of board space.

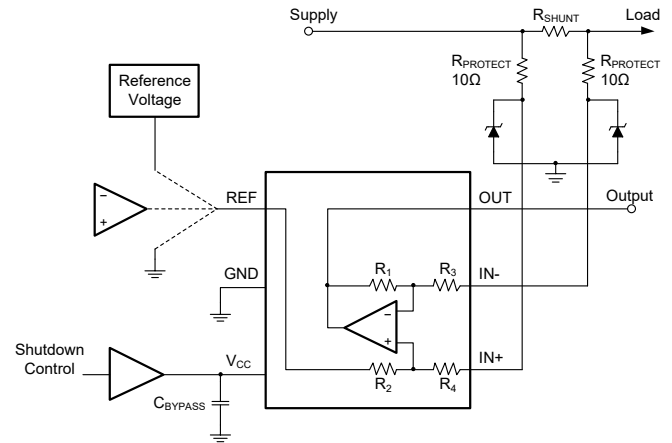

Figure 5. SGM8199 Transient Protection Using Dual Zener Diodes

In the event that low-power Zeners do not have sufficient transient absorption capability and a higher power Transzorb must be used, the most package-efficient solution then involves using a single Transzorb and back-to-back diodes between the device inputs. This method is shown in Figure 6. In both examples shown in Figure 5 and Figure 6, the total board area required by the SGM8199 with all protective components is less than that of an SOIC-8 package, and only slightly greater than that of an MSOP-8 package.

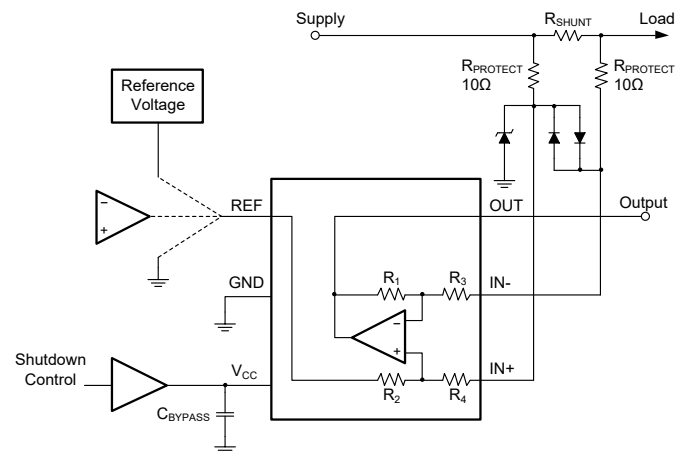

Figure 6. SGM8199 Transient Protection Using a Single Transzorb and Input Clamps

REVISION HISTORY

NOTE: Page numbers for previous revisions may differ from page numbers in the current version.

Changes from Original (SEPTEMBER 2018) to REV.A

Changed from product preview to production data.....All

PACKAGE INFORMATION

PACKAGE OUTLINE DIMENSIONS

SC70-6

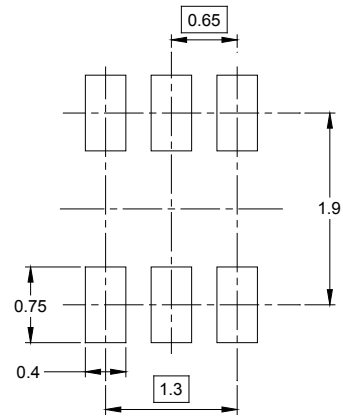
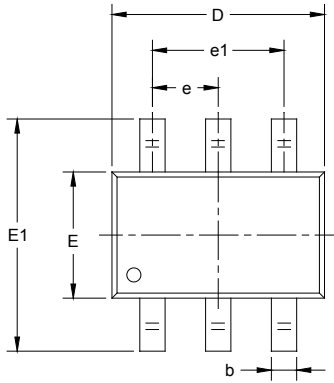

RECOMMENDED LAND PATTERN (Unit: mm)

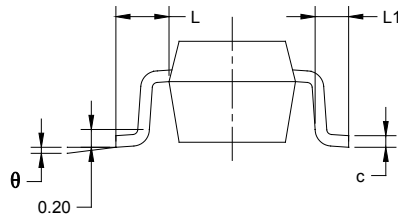
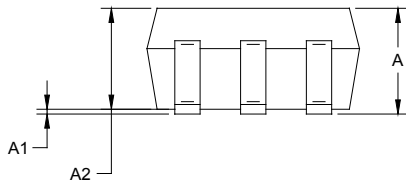

Symbol	Dimensions In Millimeters		Dimensions In Inches	
	MIN	MAX	MIN	MAX
A	0.900	1.100	0.035	0.043
A1	0.000	0.100	0.000	0.004
A2	0.900	1.000	0.035	0.039
b	0.150	0.350	0.006	0.014
c	0.080	0.150	0.003	0.006
D	2.000	2.200	0.079	0.087
E	1.150	1.350	0.045	0.053
E1	2.150	2.450	0.085	0.096
e	0.65 TYP		0.026 TYP	
e1	1.300 BSC		0.051 BSC	
L	0.525 REF		0.021 REF	
L1	0.260	0.460	0.010	0.018
θ	0°	8°	0°	8°

PACKAGE INFORMATION

TAPE AND REEL INFORMATION

REEL DIMENSIONS

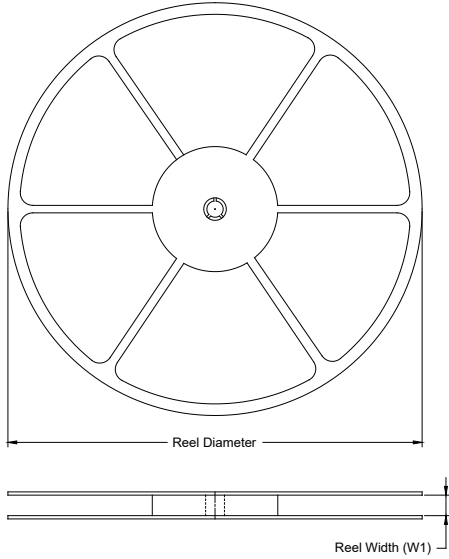

TAPE DIMENSIONS

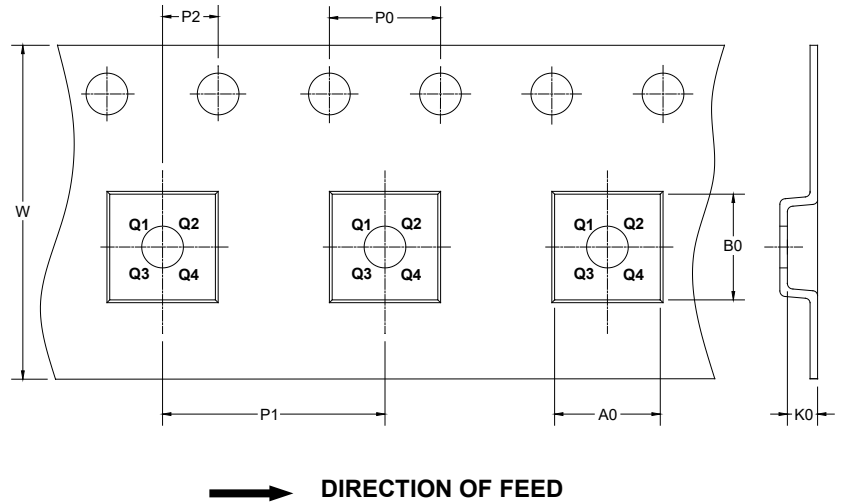

NOTE: The picture is only for reference. Please make the object as the standard.

KEY PARAMETER LIST OF TAPE AND REEL

Package Type	Reel Diameter	Reel Width W1 (mm)	A0 (mm)	B0 (mm)	K0 (mm)	P0 (mm)	P1 (mm)	P2 (mm)	W (mm)	Pin1 Quadrant
SC70-6	7"	9.5	2.40	2.50	1.20	4.0	4.0	2.0	8.0	Q3

DD0001

PACKAGE INFORMATION

CARTON BOX DIMENSIONS



NOTE: The picture is only for reference. Please make the object as the standard.

KEY PARAMETER LIST OF CARTON BOX

Reel Type	Length (mm)	Width (mm)	Height (mm)	Pizza/Carton
7" (Option)	368	227	224	8
7"	442	410	224	18

DD0002