

## 5.5-V to 36-V, 3-A STEP-DOWN SWIFT™ CONVERTER

### FEATURES

- Wide Input Voltage Range: 5.5 V to 36 V
- Up to 3-A Continuous (4-A Peak) Output Current
- High Efficiency up to 95% Enabled by 110-mΩ Integrated MOSFET Switch
- Wide Output Voltage Range: Adjustable Down to 1.22 V with 1.5% Initial Accuracy
- Internal Compensation Minimizes External Parts Count
- Fixed 500 kHz Switching Frequency for Small Filter Size
- Improved Line Regulation and Transient Response by Input Voltage Feed Forward
- System Protected by Over Current Limiting and Thermal Shutdown
- –40°C to 125°C Operating Junction Temperature Range
- Available in Small Thermally Enhanced 8-Pin SOIC PowerPAD™ Package
- For SWIFT Documentation, Application Notes and Design Software, See the TI Website at [www.ti.com/swift](http://www.ti.com/swift)

### APPLICATIONS

- Consumer: Set-top Box, DVD, LCD Displays
- Industrial and Car Audio Power Supplies
- Battery Chargers, High Power LED Supply
- 12V/24V Distributed Power Systems

### DESCRIPTION

As a member of the SWIFT™ family of DC/DC regulators, the TPS5430 is a high-output-current PWM converter that integrates a low resistance high side N-channel MOSFET. Included on the substrate with the listed features are a high performance voltage error amplifier that provides tight voltage regulation accuracy under transient conditions; an under-voltage-lockout circuit to prevent start-up until the input voltage reaches 5.5V; an internally set slow-start circuit to limit inrush currents; and a voltage feed-forward circuit to improve the transient response. Other features include an active high enable, over current protection and thermal shutdown. To reduce design complexity and external component count, the TPS5430 feedback loop is internally compensated.

The TPS5430 device is available in a thermally enhanced, easy to use 8-pin SOIC PowerPAD™ package. TI provides evaluation modules and the SWIFT™ Designer software tool to aid in quickly achieving high-performance power supply designs to meet aggressive equipment development cycles.

### SIMPLIFIED SCHEMATIC

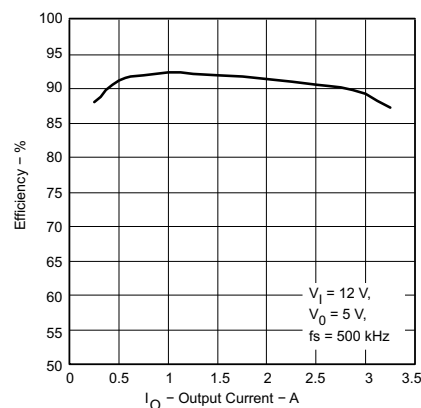
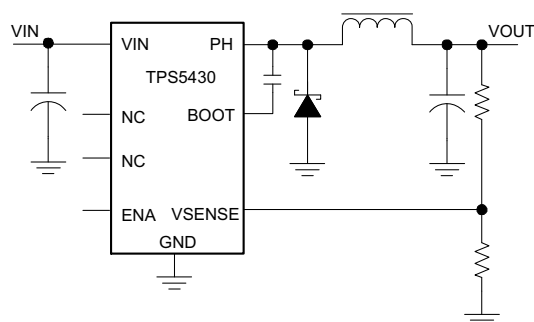

Efficiency vs Output Current



These devices have limited built-in ESD protection. The leads should be shorted together or the device placed in conductive foam during storage or handling to prevent electrostatic damage to the MOS gates.

**ORDERING INFORMATION**

T <sub>J</sub>	OUTPUT VOLTAGE	PACKAGE	PART NUMBER
–40°C to 125°C	Adjustable to 1.22 V	Thermally Enhanced SOIC (DDA) <sup>(1)</sup>	TPS5430DDA

(1) The DDA package is also available taped and reeled. Add an R suffix to the device type (i.e., TPS5430DDAR). See applications section of data sheet for PowerPAD™ drawing and layout information.

**ABSOLUTE MAXIMUM RATINGS**

over operating free-air temperature range (unless otherwise noted) <sup>(1)(2)</sup>

		VALUE	UNIT
V <sub>I</sub>	Input voltage range		V
	VIN	–0.3 to 38	
	ENA	–0.3 to 7	
	VSENSE	–0.3 to 3	
	BOOT	–0.3 to 48	
	BOOT-PH	10	
	PH (steady-state)	–0.6 to 38	
	PH (transient < 10 ns)	–1.2	
I <sub>O</sub>	Source current	PH	Internally Limited
I <sub>O</sub>	Leakage current	PH	10 μA
T <sub>J</sub>	Operating virtual junction temperature range	–40 to 125	°C
T <sub>STG</sub>	Storage temperature	–65 to 150	°C
	Lead temperature 1,6 mm (1/16-inch) from case for 10 seconds	300	°C

- (1) Stresses beyond those listed under *absolute maximum ratings* may cause permanent damage to the device. These are stress ratings only and functional operation of the device at these or any other conditions beyond those indicated under *recommended operating conditions* is not implied. Exposure to absolute-maximum-rated conditions for extended periods may affect device reliability.
- (2) All voltage values are with respect to network ground terminal.

**DISSIPATION RATINGS<sup>(1)(2)</sup>**

PACKAGE	THERMAL IMPEDANCE JUNCTION-TO-AMBIENT
8 Pin DDA (2-layer board with solder) <sup>(3)</sup>	33°C/W
8 Pin DDA (4-layer board with solder) <sup>(4)</sup>	26°C/W

- (1) Maximum power dissipation may be limited by overcurrent protection.
- (2) Power rating at a specific ambient temperature T<sub>A</sub> should be determined with a junction temperature of 125°C. This is the point where distortion starts to substantially increase. Thermal management of the final PCB should strive to keep the junction temperature at or below 125°C for best performance and long-term reliability. See *Thermal Calculations* in applications section of this data sheet for more information.
- (3) Test board conditions:
  - a. 3 in x 3 in, 2 layers, thickness: 0.062 inch.
  - b. 2 oz. copper traces located on the top and bottom of the PCB.
  - c. 6 thermal vias in the PowerPAD area under the device package.
- (4) Test board conditions:
  - a. 3 in x 3 in, 4 layers, thickness: 0.062 inch.
  - b. 2 oz. copper traces located on the top and bottom of the PCB.
  - c. 2 oz. copper ground planes on the 2 internal layers.
  - d. 6 thermal vias in the PowerPAD area under the device package.

**RECOMMENDED OPERATING CONDITIONS**

		MIN	NOM	MAX	UNIT
VIN	Input voltage range	5.5		36	V
T <sub>J</sub>	Operating junction temperature	–40		125	°C

**ELECTRICAL CHARACTERISTICS**T<sub>J</sub> = –40°C to 125°C, V<sub>IN</sub> = 5.5 V to 36.0 V (unless otherwise noted)

PARAMETER		TEST CONDITIONS	MIN	TYP	MAX	UNIT
<b>SUPPLY VOLTAGE (VIN PIN)</b>						
V <sub>IN</sub>	Input voltage range		5.5		36	V
I <sub>Q</sub>	Quiescent current	VSENSE = 2 V, Not switching, PH pin open		3	4.4	mA
		Shutdown, ENA = 0 V		18	50	μA
<b>UNDER VOLTAGE LOCK OUT (UVLO)</b>						
	Start threshold voltage, UVLO			5.3	5.5	V
	Hysteresis voltage, UVLO			330		mV
<b>VOLTAGE REFERENCE</b>						
	Voltage reference accuracy	T <sub>J</sub> = 25°C	1.202	1.221	1.239	V
		I <sub>o</sub> = 0 A – 3 A	1.196	1.221	1.245	
<b>OSCILLATOR</b>						
	Internally set free-running frequency		400	500	600	kHz
	Minimum controllable on time			150	200	ns
	Maximum duty cycle		87	89		%
<b>ENABLE (ENA PIN)</b>						
	Start threshold voltage, ENA				1.3	V
	Stop threshold voltage, ENA		0.5			V
	Hysteresis voltage, ENA			450		mV
	Internal slow-start time (0–100%)		6.6	8	10	ms
<b>CURRENT LIMIT</b>						
	Current limit		4.0	5.0	6.0	A
	Current limit hiccup time		13	16	20	ms
<b>THERMAL SHUTDOWN</b>						
	Thermal shutdown trip point		135	162		°C
	Thermal shutdown hysteresis			14		°C
<b>OUTPUT MOSFET</b>						
R <sub>DS-ON</sub>	High side power MOSFET switch	V <sub>IN</sub> = 5.5 V		150		mΩ
		V <sub>IN</sub> = 10 V – 36 V		110	230	

**PIN ASSIGNMENTS**

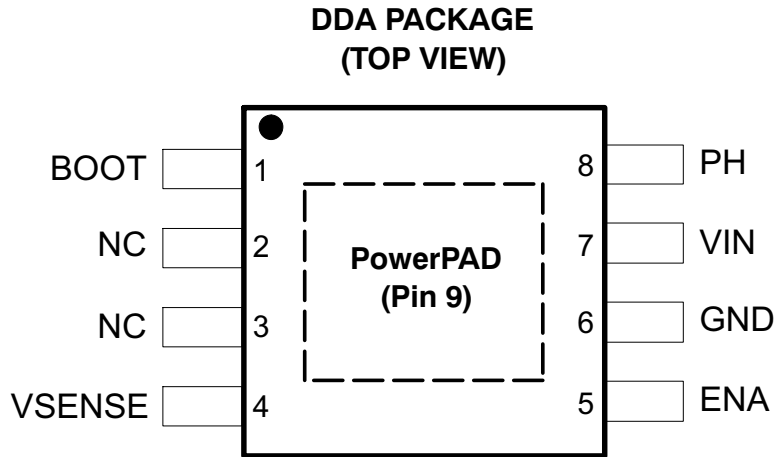

**TERMINAL FUNCTIONS**

TERMINAL		DESCRIPTION
NAME	NO.	
BOOT	1	Boost capacitor for the high-side FET gate driver. Connect 0.01 $\mu$ F low ESR capacitor from BOOT pin to PH pin.
NC	2, 3	Not connected internally.
VSENSE	4	Feedback voltage for the regulator. Connect to output voltage divider.
ENA	5	On/off control. Below 0.5 V, the device stops switching. Float the pin to enable.
GND	6	Ground. Connect to PowerPAD.
VIN	7	Input supply voltage. Bypass VIN pin to GND pin close to device package with a high quality, low ESR ceramic capacitor.
PH	8	Source of the high side power MOSFET. Connected to external inductor and diode.
PowerPAD	9	GND pin must be connected to the exposed pad for proper operation.

TYPICAL CHARACTERISTICS

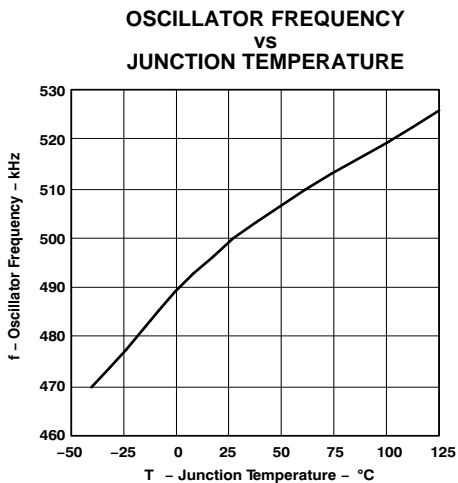

Figure 1.

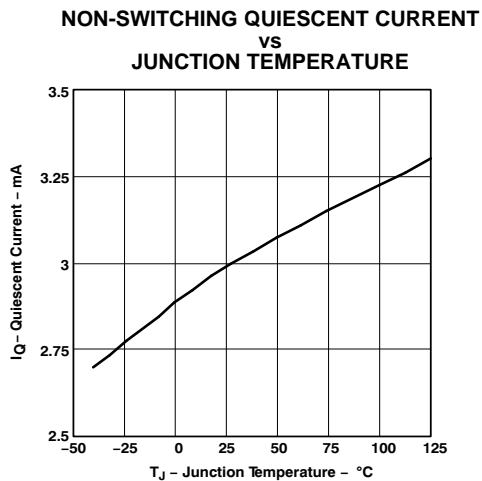

Figure 2.

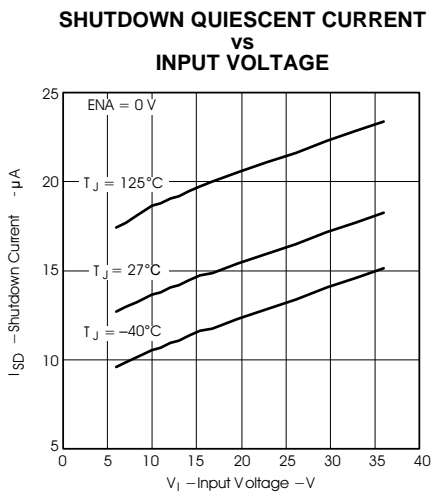

Figure 3.

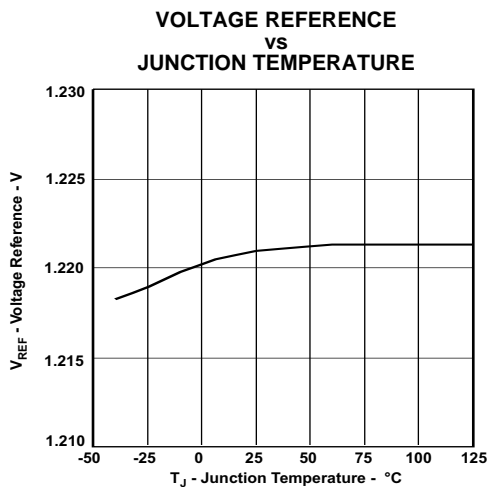

Figure 4.

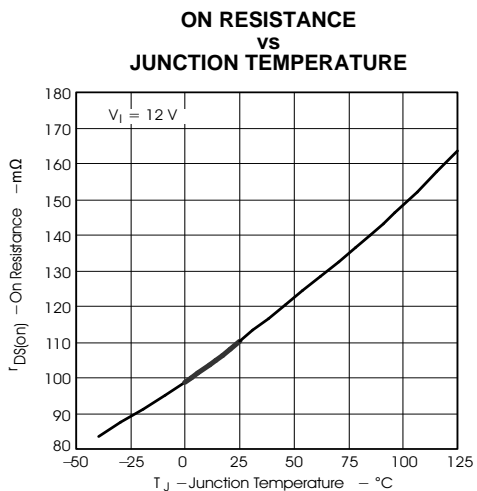

Figure 5.

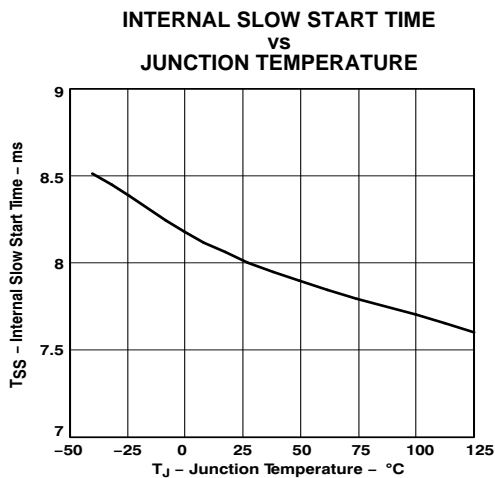

Figure 6.

TYPICAL CHARACTERISTICS (continued)

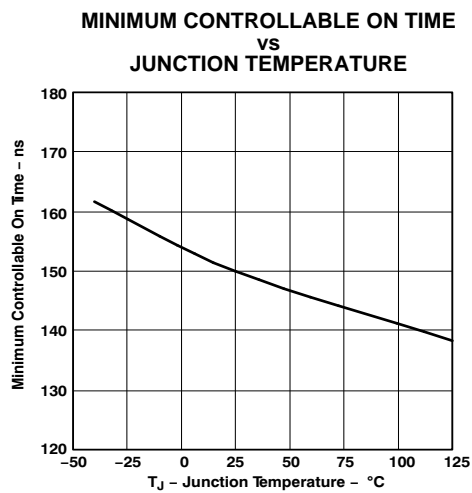

Figure 7.

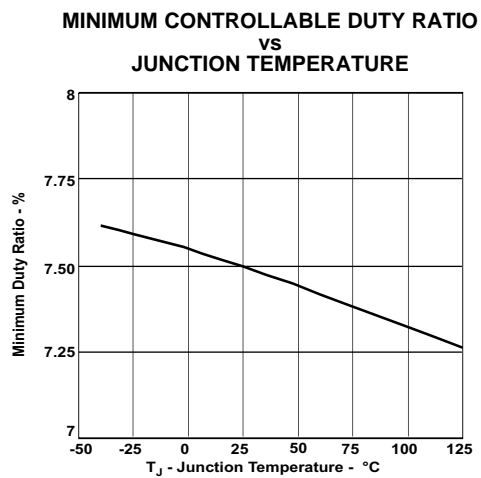

Figure 8.



## APPLICATION INFORMATION (continued)

### Undervoltage Lockout (UVLO)

The TPS5430 incorporates an under voltage lockout circuit to keep the device disabled when VIN (the input voltage) is below the UVLO start voltage threshold. During power up, internal circuits are held inactive until VIN exceeds the UVLO start threshold voltage. Once the UVLO start threshold voltage is reached, device start-up begins. The device operates until VIN falls below the UVLO stop threshold voltage. The typical hysteresis in the UVLO comparator is 330 mV.

### Boost Capacitor (BOOT)

Connect a 0.01  $\mu$ F low-ESR ceramic capacitor between the BOOT pin and PH pin. This capacitor provides the gate drive voltage for the high-side MOSFET. X7R or X5R grade dielectrics are recommended due to their stable values over temperature.

### Output Feedback (VSENSE) and Internal Compensation

The output voltage of the regulator is set by feeding back the center point voltage of an external resistor divider network to the VSENSE pin. In steady-state operation, the VSENSE pin voltage should be equal to the voltage reference 1.221 V.

The TPS5430 implements internal compensation to simplify the regulator design. Since the TPS5430 uses voltage mode control, a type 3 compensation network has been designed on chip to provide a high crossover frequency and a high phase margin for good stability. Refer to *Internal Compensation Network* in the applications section for more details.

### Voltage Feed Forward

The internal voltage feed forward provides a constant DC power stage gain despite any variations with the input voltage. This greatly simplifies the stability analysis and improves the transient response. Voltage feed forward varies the peak ramp voltage inversely with the input voltage so that the modulator and power stage gain are constant at the feed forward gain, i.e.

$$\text{Feed Forward Gain} + \frac{V_{IN}}{\text{Ramp}_{pk \times pk}} \quad (1)$$

The typical feed forward gain of TPS5430 is 25.

### Pulse-Width-Modulation (PWM) Control

The regulator employs a fixed frequency pulse-width-modulator (PWM) control method. First, the feedback voltage (VSENSE pin voltage) is compared to the constant voltage reference by the high gain error amplifier and compensation network to produce a error voltage. Then, the error voltage is compared to the ramp voltage by the PWM comparator. In this way, the error voltage magnitude is converted to a pulse width which is the duty cycle. Finally, the PWM output is fed into the gate drive circuit to control the on-time of the high-side MOSFET.

### Overcurrent Protection

Overcurrent protection is implemented by sensing the drain-to-source voltage across the high-side MOSFET. The drain to source voltage is then compared to a voltage level representing the overcurrent threshold limit. If the drain-to-source voltage exceeds the overcurrent threshold limit, the overcurrent indicator is set true. The system will ignore the overcurrent indicator for the leading edge blanking time at the beginning of each cycle to avoid any turn-on noise glitches.

Once overcurrent indicator is set true, overcurrent protection is triggered. The high-side MOSFET is turned off for the rest of the cycle after a propagation delay. The overcurrent protection scheme is called cycle-by-cycle current limiting.

If the sensed current continues to increase during cycle-by-cycle current limiting, the hiccup mode overcurrent protection will be triggered instead of cycle-by-cycle current limiting. During hiccup mode overcurrent protection, the voltage reference is grounded and the high-side MOSFET is turned off for the hiccup time. Once the hiccup time duration is complete, the regulator restarts under control of the slow start circuit.



---

## APPLICATION INFORMATION (continued)

### Thermal Shutdown

The TPS5430 protects itself from overheating with an internal thermal shutdown circuit. If the junction temperature exceeds the thermal shutdown trip point, the voltage reference is grounded and the high-side MOSFET is turned off. The part is restarted under control of the slow start circuit automatically when the junction temperature drops 14°C below the thermal shutdown trip point.

### PCB Layout

Connect a low ESR ceramic bypass capacitor to the VIN pin. Care should be taken to minimize the loop area formed by the bypass capacitor connections, the VIN pin, and the TPS5430 ground pin. The best way to do this is to extend the top side ground area from under the device adjacent to the VIN trace, and place the bypass capacitor as close as possible to the VIN pin. The minimum recommended bypass capacitance is 10 uF ceramic with a X5R or X7R dielectric.

There should be a ground area on the top layer directly underneath the IC, with an exposed area for connection to the PowerPAD. Use vias to connect this ground area to any internal ground planes. Use additional vias at the ground side of the input and output filter capacitors as well. The GND pin should be tied to the PCB ground by connecting it to the ground area under the device as shown below.

The PH pin should be routed to the output inductor, catch diode and boot capacitor. Since the PH connection is the switching node, the inductor should be located very close to the PH pin and the area of the PCB conductor minimized to prevent excessive capacitive coupling. The catch diode should also be placed close to the device to minimize the output current loop area. Connect the boot capacitor between the phase node and the BOOT pin as shown. Keep the boot capacitor close to the IC and minimize the conductor trace lengths. The component placements and connections shown work well, but other connection routings may also be effective.

Connect the output filter capacitor(s) as shown between the VOUT trace and GND. It is important to keep the loop formed by the PH pin, Lout, Cout and GND as small as is practical.

Connect the VOUT trace to the VSENSE pin using the resistor divider network to set the output voltage. Do not route this trace too close to the PH trace. Due to the size of the IC package and the device pin-out, the trace may need to be routed under the output capacitor. Alternately, the routing may be done on an alternate layer if a trace under the output capacitor is not desired.

If the grounding scheme shown is utilized, use a via connection to a different layer to route to the ENA pin.

APPLICATION INFORMATION (continued)

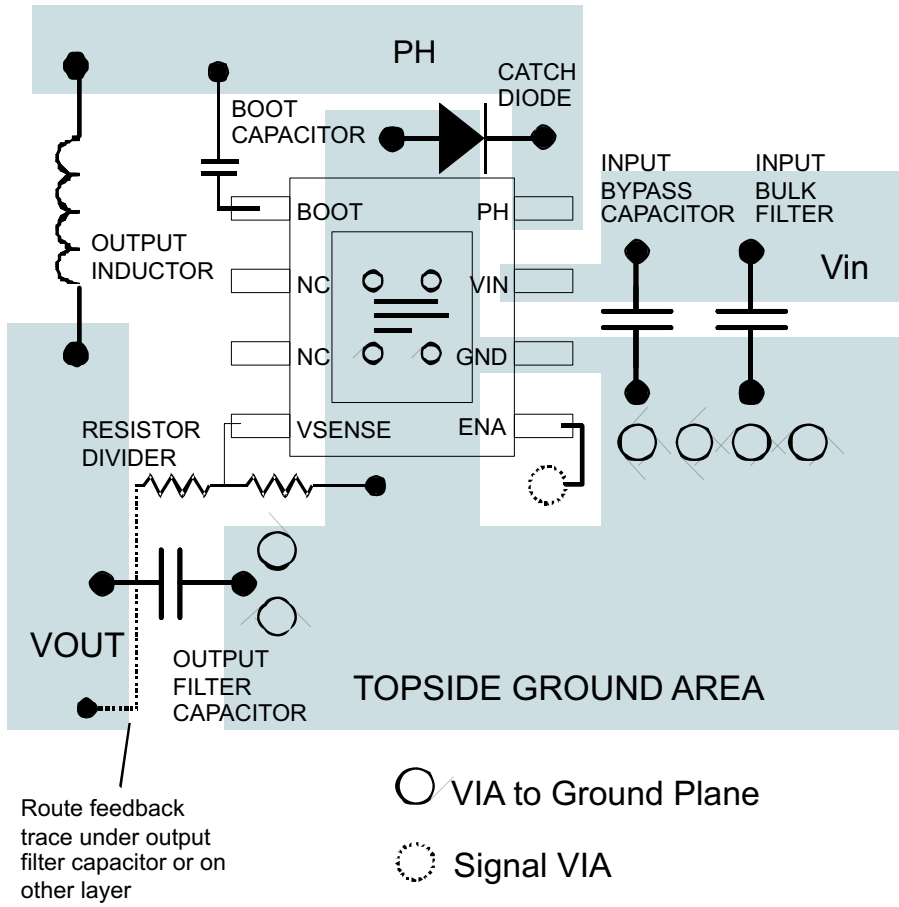
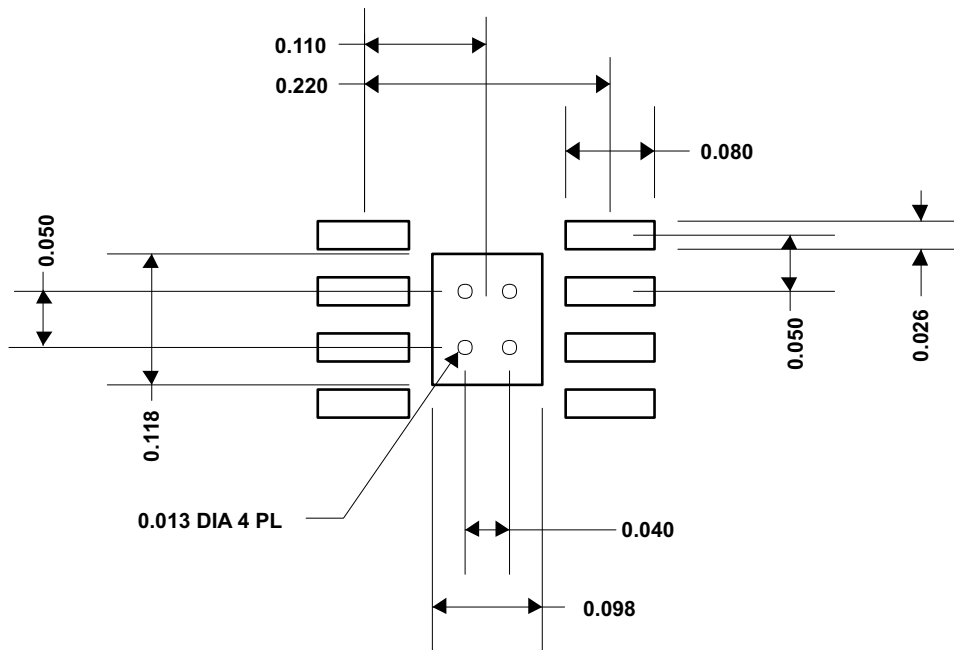

Figure 9. Design Layout

## APPLICATION INFORMATION (continued)



All dimensions in inches

Figure 10. TPS5430 Land Pattern

### Application Circuits

Figure 11 shows the schematic for a typical TPS5430 application. The TPS5430 can provide up to 3-A output current at a nominal output voltage of 5.0 V. For proper thermal performance the exposed PowerPAD underneath the device must be soldered down to the printed circuit board.

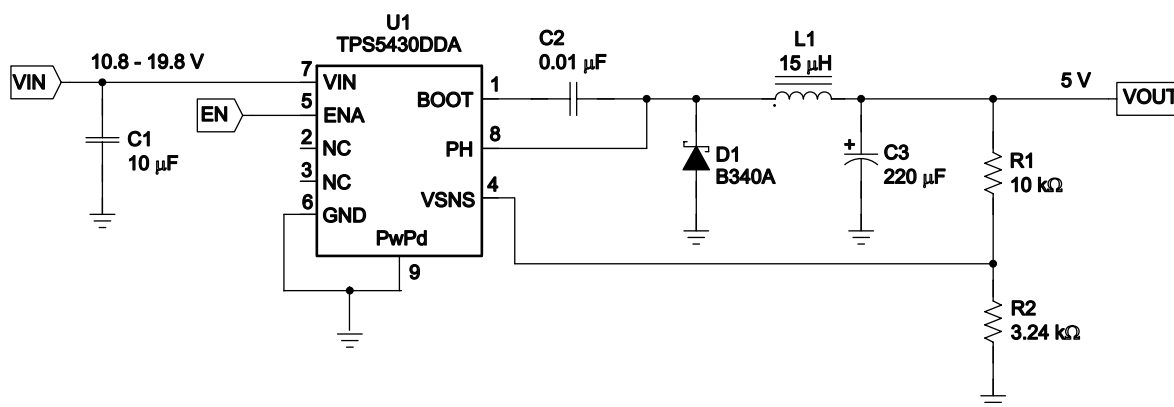

Figure 11. Application Circuit, 12-V to 5.0-V

### Design Procedure

The following design procedure can be used to select component values for the TPS5430. Alternately, the SWIFT Designer Software may be used to generate a complete design. The SWIFT Designer Software uses an iterative design procedure and accesses a comprehensive database of components when generating a design. This section presents a simplified discussion of the design process.

To begin the design process a few parameters must be decided upon. The designer needs to know the following:

## APPLICATION INFORMATION (continued)

- Input voltage range
- Output voltage
- Input ripple voltage
- Output ripple voltage
- Output current rating
- Operating frequency

**Design Parameters**

For this design example, use the following as the input parameters:

DESIGN PARAMETER <sup>(1)</sup>	EXAMPLE VALUE
Input voltage range	10.8 V to 19.8 V
Output voltage	5.0 V
Input ripple voltage	300 mV
Output ripple voltage	30 mV
Output current rating	3 A
Operating frequency	500 kHz

(1) As an additional constraint, the design is set up to be small size and low component height.

**Switching Frequency**

The switching frequency for the TPS5430 is internally set to 500 kHz. It is not possible to adjust the switching frequency.

**Input Capacitors**

The TPS5430 requires an input decoupling capacitor and, depending on the application, a bulk input capacitor. The recommended value for the decoupling capacitor, C1, is 10  $\mu$ F. A high quality ceramic type X5R or X7R is required. For some applications a smaller value decoupling capacitor may be used, so long as the input voltage and current ripple ratings are not exceeded. The voltage rating must be greater than the maximum input voltage, including ripple.

This input ripple voltage can be approximated by [Equation 2](#) :

$$\pi V_{IN} \frac{I_{OUT(MAX)} \times 0.25}{C_{BULK} \times f_{sw}} + (I_{OUT(MAX)} \times ESR_{MAX}) \quad (2)$$

Where  $I_{OUT(MAX)}$  is the maximum load current,  $f_{sw}$  is the switching frequency,  $C_{IN}$  is the input capacitor value and  $ESR_{MAX}$  is the maximum series resistance of the input capacitor.

The maximum RMS ripple current also needs to be checked. For worst case conditions, this can be approximated by [Equation 3](#) :

$$I_{CIN} \times \frac{I_{OUT(MAX)}}{2} \quad (3)$$

In this case the input ripple voltage would be 156 mV and the RMS ripple current would be 1.5 A. The maximum voltage across the input capacitors would be  $V_{IN\ max} + \Delta V_{IN}/2$ . The chosen input decoupling capacitor is rated for 25 V and the ripple current capacity is greater than 3 A, providing ample margin. It is very important that the maximum ratings for voltage and current are not exceeded under any circumstance.

Additionally some bulk capacitance may be needed, especially if the TPS5430 circuit is not located within about 2 inches from the input voltage source. The value for this capacitor is not critical but it also should be rated to handle the maximum input voltage including ripple voltage and should filter the output so that input ripple voltage is acceptable.

### Output Filter Componts

Two components need to be selected for the output filter, L1 and C2. Since the TPS5430 is an internally compensated device, a limited range of filter component types and values can be supported.

#### Inductor Selection

To calculate the minimum value of the output inductor, use [Equation 4](#):

$$L_{\text{MIN}} = \frac{V_{\text{OUT(MAX)}} \times (V_{\text{IN(MAX)}} + V_{\text{OUT}})}{V_{\text{IN(max)}} \times K_{\text{IND}} \times I_{\text{OUT}} \times F_{\text{SW}}} \quad (4)$$

$K_{\text{IND}}$  is a coefficient that represents the amount of inductor ripple current relative to the maximum output current. Three things need to be considered when determining the amount of ripple current in the inductor: the peak to peak ripple current affects the output ripple voltage amplitude, the ripple current affects the peak switch current and the amount of ripple current determines at what point the circuit will become discontinuous. For designs using the TPS5430,  $K_{\text{IND}}$  of 0.2 to 0.3 yields good results. Low output ripple voltages can be obtained when paired with the proper output capacitor, the peak switch current will be well below the current limit set point and relatively low load currents can be sourced before discontinuous operation.

For this design example use  $K_{\text{IND}} = 0.2$  and the minimum inductor value is calculated to be 12.5 $\mu\text{H}$ . The next highest standard value is 15  $\mu\text{H}$ , which is used in this design.

For the output filter inductor it is important that the RMS current and saturation current ratings not be exceeded. The RMS inductor current can be found from [Equation 5](#):

$$I_{\text{L(RMS)}} = \sqrt{\left( I_{\text{OUT(MAX)}}^2 + \frac{1}{12} \times \frac{V_{\text{OUT}} \times V_{\text{IN(MAX)}}}{V_{\text{IN(MAX)}} \times L_{\text{OUT}} \times F_{\text{SW}} \times 0.8} \right)} \quad (5)$$

and the peak inductor current can be determined with [Equation 6](#):

$$I_{\text{L(PK)}} = I_{\text{OUT(MAX)}} + \frac{V_{\text{OUT}} \times V_{\text{IN(MAX)}}}{1.6 \times V_{\text{IN(MAX)}} \times L_{\text{OUT}} \times F_{\text{SW}}} \quad (6)$$

For this design, the RMS inductor current is 3.003 A, and the peak inductor current is 3.31 A. The chosen inductor is a Sumida CDRH104R-150 15 $\mu\text{H}$ . It has a saturation current rating of 3.4 A and a RMS current rating of 3.6 A, easily meeting these requirements. A lesser rated inductor could be used, however this device was chosen because of its low profile component height. In general, inductor values for use with the TPS5430 are in the range of 10  $\mu\text{H}$  to 100  $\mu\text{H}$ .

#### Capacitor Selection

The important design factors for the output capacitor are dc voltage rating, ripple current rating, and equivalent series resistance (ESR). The dc voltage and ripple current ratings cannot be exceeded. The ESR is important because along with the inductor ripple current it determines the amount of output ripple voltage. The actual value of the output capacitor is not critical, but some practical limits do exist. Consider the relationship between the desired closed loop crossover frequency of the design and LC corner frequency of the output filter. Due to the design of the internal compensation, it is desirable to keep the closed loop crossover frequency in the range 3 kHz to 30 kHz as this frequency range has adequate phase boost to allow for stable operation. For this design example, it is assumed that the intended closed loop crossover frequency will be between 2590 Hz and 24 kHz and also below the ESR zero of the output capacitor. Under these conditions the closed loop crossover frequency will be related to the LC corner frequency by:

$$f_{\text{CO}} \times \frac{f_{\text{LC}}^2}{85 V_{\text{OUT}}} \quad (7)$$

And the desired output capacitor value for the output filter to:

$$C_{OUT} + \frac{1}{3357 \times L_{OUT} \times f_{CO} \times V_{OUT}} \quad (8)$$

For a desired crossover of 18 kHz and a 15-μH inductor, the calculated value for the output capacitor is 220 μF. The capacitor type should be chosen so that the ESR zero is above the loop crossover. The maximum ESR should be: (Add new equation)

$$ESR_{MAX} + \frac{1}{2\pi \times C_{OUT} \times f_{CO}} \quad (9)$$

The maximum ESR of the output capacitor also determines the amount of output ripple as specified in the initial design parameters. The output ripple voltage is the inductor ripple current times the ESR of the output filter. Check that the maximum specified ESR as listed in the capacitor data sheet will result in an acceptable output ripple voltage:

$$\pi V_{p-p(MAX)} \frac{ESR_{MAX} \times V_{OUT} \times (V_{IN(MAX)} + V_{OUT})}{N_C \times V_{IN(MAX)} \times L_{OUT} \times F_{SW}} \quad (10)$$

Where:

Δ V<sub>p-p</sub> is the desired peak-to-peak output ripple.

N<sub>C</sub> is the number of parallel output capacitors.

F<sub>SW</sub> is the switching frequency.

For this design example, a single 220-μF output capacitor is chosen for C3. The calculated RMS ripple current is 143 mA and the maximum ESR required is 40 mΩ. A capacitor that meets these requirements is a Sanyo Poscap 10TPB220M, rated at 10 V with a maximum ESR of 40 mΩ and a ripple current rating of 3.0 A. An additional small 0.1-μF ceramic bypass capacitor may also be used, but is not included in this design.

The minimum ESR of the output capacitor should also be considered. For good phase margin, the ESR zero when the ESR is at a minimum should not be too far above the internal compensation poles at 24 and 54 kHz.

The selected output capacitor must also be rated for a voltage greater than the desired output voltage plus one half the ripple voltage. Any derating amount must also be included. The maximum RMS ripple current in the output capacitor is given by [Equation 11](#):

$$I_{COUT(RMS)} \frac{1}{12} \times \left[ \frac{V_{OUT} \times (V_{IN(MAX)} + V_{OUT})}{V_{IN(MAX)} \times L_{OUT} \times F_{SW} \times N_C} \right] \quad (11)$$

Where:

N<sub>C</sub> is the number of output capacitors in parallel.

F<sub>SW</sub> is the switching frequency.

Other capacitor types can be used with the TPS5430, depending on the needs of the application.

### Output Voltage Setpoint

The output voltage of the TPS5430 is set by a resistor divider (R1 and R2) from the output to the VSENSE pin. Calculate the R2 resistor value for the output voltage of 5.0 V using [Equation 12](#):

$$R2 \frac{R1 \times 1.221}{V_{OUT} + 1.221} \quad (12)$$

For any TPS5430 design, start with an R1 value of 10 kΩ. R2 is then 3.24 kΩ.

### Boot Capacitor

The boot capacitor should be 0.01 μF.

### Catch Diode

The TPS5430 is designed to operate using an external catch diode between PH and GND. The selected diode must meet the absolute maximum ratings for the application: Reverse voltage must be higher than the maximum voltage at the PH pin, which is  $V_{INMAX} + 0.5$  V. Peak current must be greater than  $I_{OUTMAX}$  plus on half the peak to peak inductor current. Forward voltage drop should be small for higher efficiencies. It is important to note that the catch diode conduction time is typically longer than the high-side FET on time, so attention paid to diode parameters can make a marked improvement in overall efficiency. Additionally, check that the device chosen is capable of dissipating the power losses. For this design, a Diodes, Inc. B340A is chosen, with a reverse voltage of 40 V, forward current of 3 A, and a forward voltage drop of 0.5V.

### Additional Circuits

Figure 12 shows an application circuit utilizing a wide input voltage range. The design parameters are similar to those given for the design example, with a larger value output inductor and a lower closed loop crossover frequency.

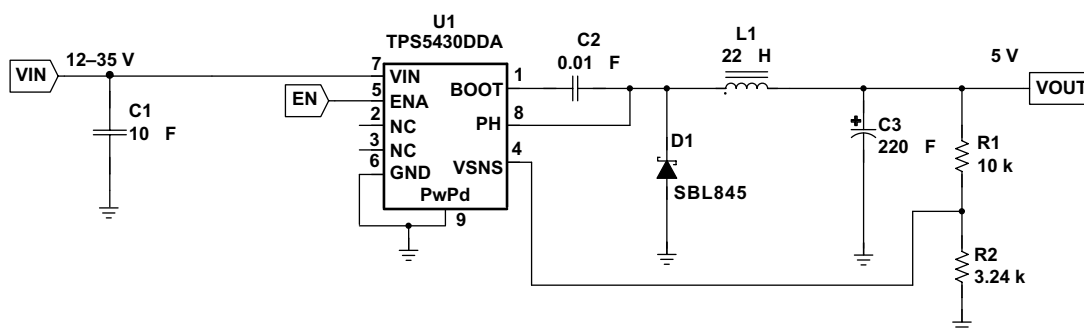

Figure 12. 12-35 V Input to 5 V Output Application Circuit

## ADVANCED INFORMATION

### Output Voltage Limitations

Due to the internal design of the TPS5430, there are both upper and lower output voltage limits for any given input voltage. The upper limit of the output voltage set point is constrained by the maximum duty cycle of 87% and is given by:

$$V_{OUTMAX} = \left( 0.87 \times \left( V_{INMIN} - I_{OMAX} \times 0.230 + V_D \right) \right) - I_{OMAX} \times R_L - V_D \quad (13)$$

Where

$V_{INMIN}$  = minimum input voltage

$I_{OMAX}$  = maximum load current

$V_D$  = catch diode forward voltage.

$R_L$  = output inductor series resistance.

This equation assumes maximum on resistance for the internal high side FET.

The lower limit is constrained by the minimum controllable on time which may be as high as 200nsec. The approximate minimum output voltage for a given input voltage and minimum load current is given by:

$$V_{OUTMIN} = \left( 0.12 \times \left( V_{INMAX} - I_{OMIN} \times 0.110 + V_D \right) \right) - I_{OMIN} \times R_L - V_D \quad (14)$$

Where

$V_{INMAX}$  = maximum input voltage

$I_{OMIN}$  = minimum load current

$V_D$  = catch diode forward voltage.

$R_L$  = output inductor series resistance.

This equation assumes nominal on resistance for the high side FET and accounts for worst case variation of operating frequency set point. Any design operating near the operational limits of the device should be carefully checked to assure proper functionality.

**Internal Compensation Network**

The design equations given in the example circuit can be used to generate circuits using the TPS5430. These designs are based on certain assumptions and will tend to always select output capacitors within a limited range of ESR values. If a different capacitor type is desired, it may be possible to fit one to the internal compensation of the TPS5430. Equation 15 gives the nominal frequency response of the internal voltage-mode type III compensation network:

$$H(s) = \frac{\left(1 + \frac{s}{2\pi \times Fz1}\right) \times \left(1 + \frac{s}{2\pi \times Fz2}\right)}{\left(\frac{s}{2\pi \times Fp0}\right) \times \left(1 + \frac{s}{2\pi \times Fp1}\right) \times \left(1 + \frac{s}{2\pi \times Fp2}\right) \times \left(1 + \frac{s}{2\pi \times Fp3}\right)} \tag{15}$$

Where

Fp0 = 2165 Hz, Fz1 = 2170 Hz, Fz2 = 2590 Hz

Fp1 = 24 kHz, Fp2 = 54 kHz, Fp3 = 440 kHz

Fp3 represents the non-ideal parasitics effect.

Using this information along with the desired output voltage, feed forward gain and output filter characteristics, the closed loop transfer function can be derived.

**Thermal Calculations**

The following formulas show how to estimate the device power dissipation under continuous conduction mode operations. They should not be used if the device is working at light loads in the discontinuous conduction mode.

**Conduction Loss:**  $P_{con} = I_o^2 \times R_{ds,on} \times V_{OUT}/V_{IN}$

**Switching Loss:**  $P_{sw} = V_{IN} \times I_{OUT} \times 0.01$

**Quiescent Current Loss:**  $P_q = V_{IN} \times 0.01$

**Total Loss:**  $P_{tot} = P_{con} + P_{sw} + P_q$

**Given  $T_A \Rightarrow$  Estimated Junction Temperature:**  $T_J = T_A + R_{th} \times P_{tot}$

**Given  $T_{JMAX} = 125^\circ C \Rightarrow$  Estimated Maximum Ambient Temperature:**  $T_{AMAX} = T_{JMAX} - R_{th} \times P_{tot}$



**PERFORMANCE GRAPHS**

The performance graphs in Figures 12 - 18 are applicable to the circuit in Figure 10.  $T_a = 25\text{ }^\circ\text{C}$ . unless otherwise specified.

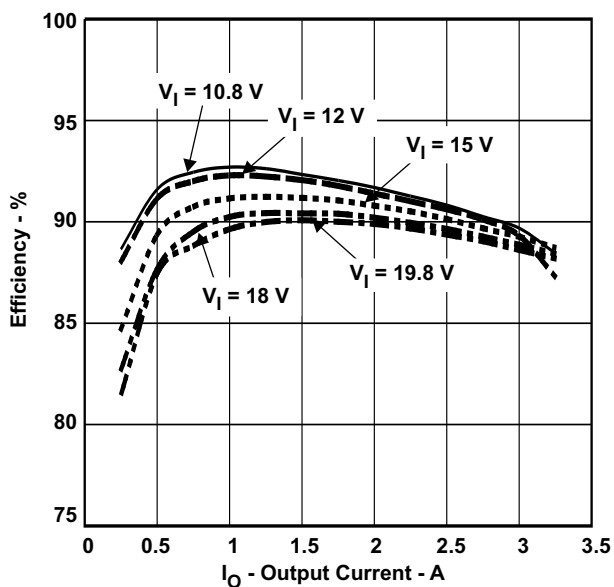

Figure 13. Efficiency vs. Output Current

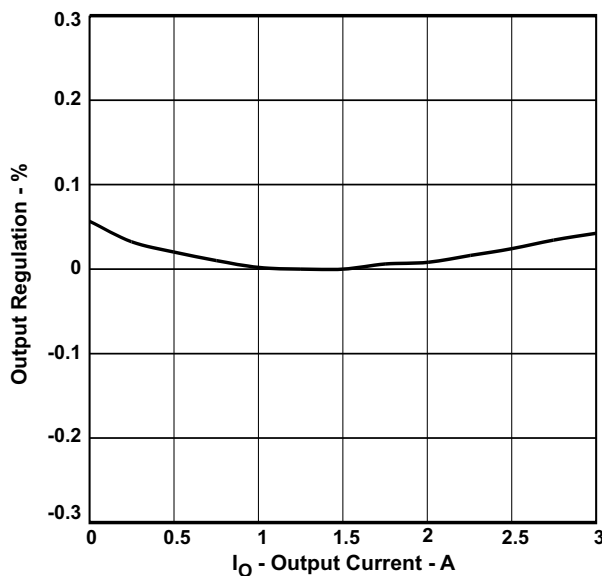

Figure 14. Output Regulation % vs. Output Current

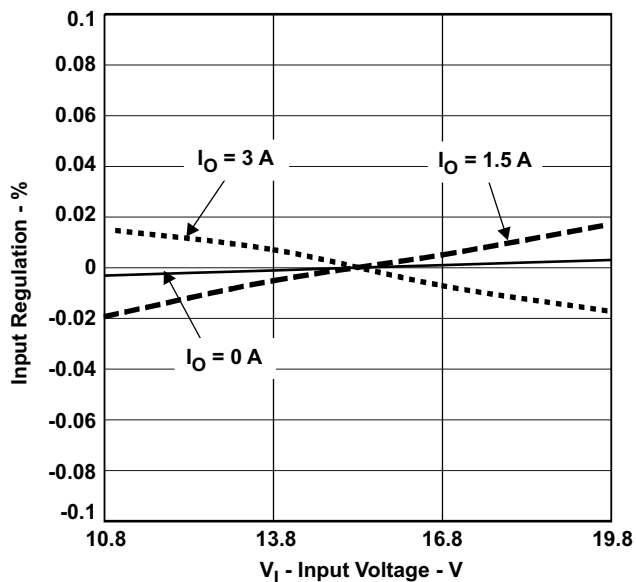

Figure 15. Input Regulation % vs. Input Voltage

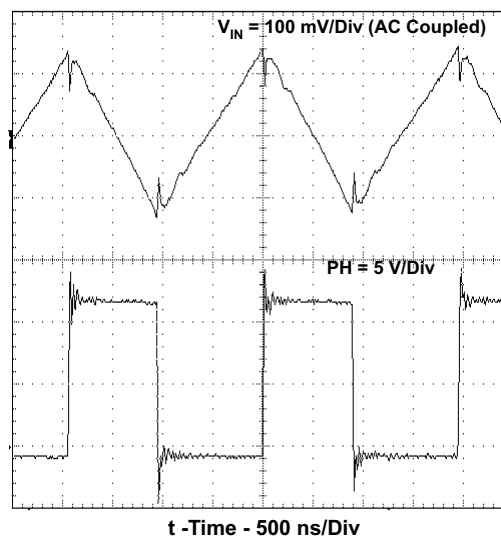

Figure 16. Input Voltage Ripple and PH Node,  $I_o = 3\text{ A}$ .

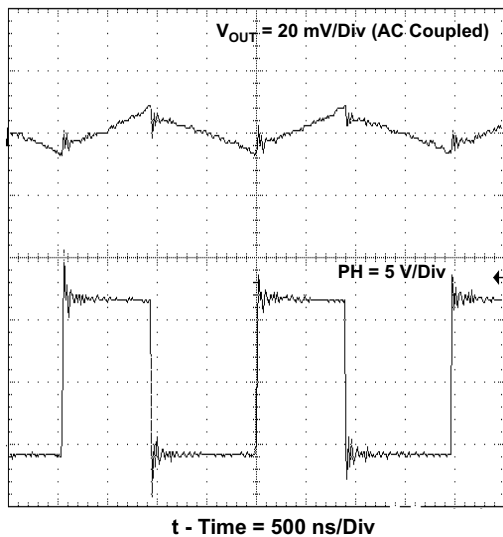

Figure 17. Output Voltage Ripple and PH Node,  $I_o = 3 \text{ A}$

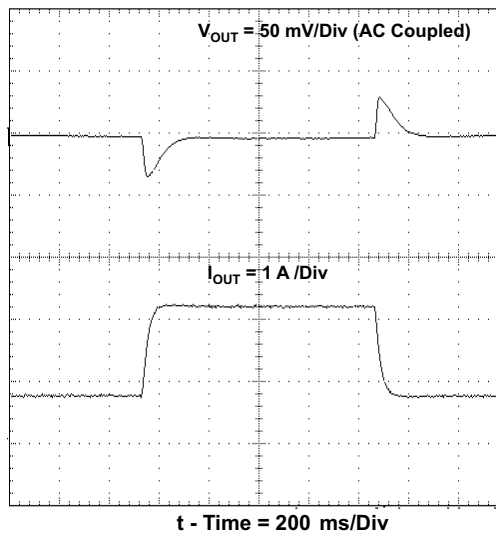

Figure 18. Transient Response,  $I_o$  Step 0.75 to 2.25 A.

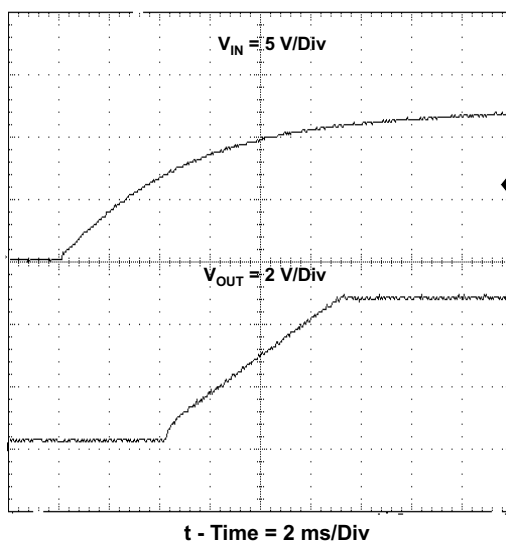

Figure 19. Startup Waveform,  $V_{in}$  and  $V_{out}$ .

THERMAL INFORMATION

This PowerPAD™ package incorporates an exposed thermal pad that is designed to be attached directly to an external heatsink. When the thermal pad is soldered directly to the printed circuit board (PCB), the PCB can be used as a heatsink. In addition, through the use of thermal vias, the thermal pad can be attached directly to a ground or power plane (whichever is applicable), or alternatively, a special heatsink structure designed into the PCB. This design optimizes the heat transfer from the integrated circuit (IC).

For additional information on the PowerPAD package and how to take advantage of its heat dissipating abilities, refer to Technical Brief, PowerPAD Thermally Enhanced Package, Texas Instruments Literature No. SLMA002 and Application Brief, PowerPAD Made Easy, Texas Instruments Literature No. SLMA004. Both documents are available at [www.ti.com](http://www.ti.com).

The exposed thermal pad dimensions for this package are shown in the following illustration.

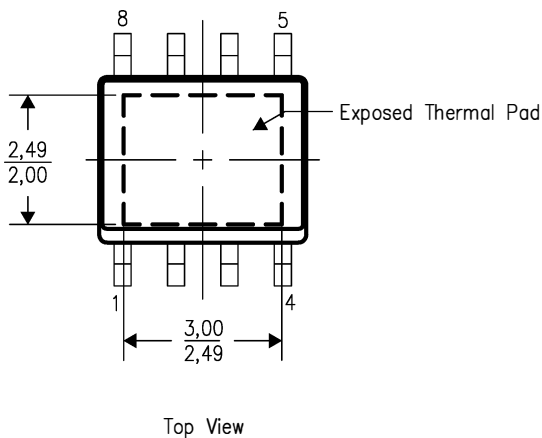

NOTE: All linear dimensions are in millimeters

Exposed Thermal Pad Dimensions

# PACKAGE OPTION ADDENDUM

10-Feb-2006

## PACKAGING INFORMATION

Orderable Device	Status <sup>(1)</sup>	Package Type	Package Drawing	Pins	Package Qty	Eco Plan <sup>(2)</sup>	Lead/Ball Finish	MSL Peak Temp <sup>(3)</sup>
TPS5430DDA	ACTIVE	SO Power PAD	DDA	8	75	Green (RoHS & no Sb/Br)	CU NIPDAU	Level-1-260C-UNLIM
TPS5430DDAG4	ACTIVE	SO Power PAD	DDA	8	75	Green (RoHS & no Sb/Br)	CU NIPDAU	Level-1-260C-UNLIM
TPS5430DDAR	ACTIVE	SO Power PAD	DDA	8	2500	Green (RoHS & no Sb/Br)	CU NIPDAU	Level-1-260C-UNLIM
TPS5430DDARG4	ACTIVE	SO Power PAD	DDA	8	2500	Green (RoHS & no Sb/Br)	CU NIPDAU	Level-1-260C-UNLIM

**Important Information and Disclaimer:**The information provided on this page represents TI's knowledge and belief as of the date that it is provided. TI bases its knowledge and belief on information provided by third parties, and makes no representation or warranty as to the accuracy of such information. Efforts are underway to better integrate information from third parties. TI has taken and continues to take reasonable steps to provide representative and accurate information but may not have conducted destructive testing or chemical analysis on incoming materials and chemicals. TI and TI suppliers consider certain information to be proprietary, and thus CAS numbers and other limited information may not be available for release.

In no event shall TI's liability arising out of such information exceed the total purchase price of the TI part(s) at issue in this document sold by TI to Customer on an annual basis.

DDA (R-PDSO-G8)

PowerPAD™ PLASTIC SMALL-OUTLINE PACKAGE

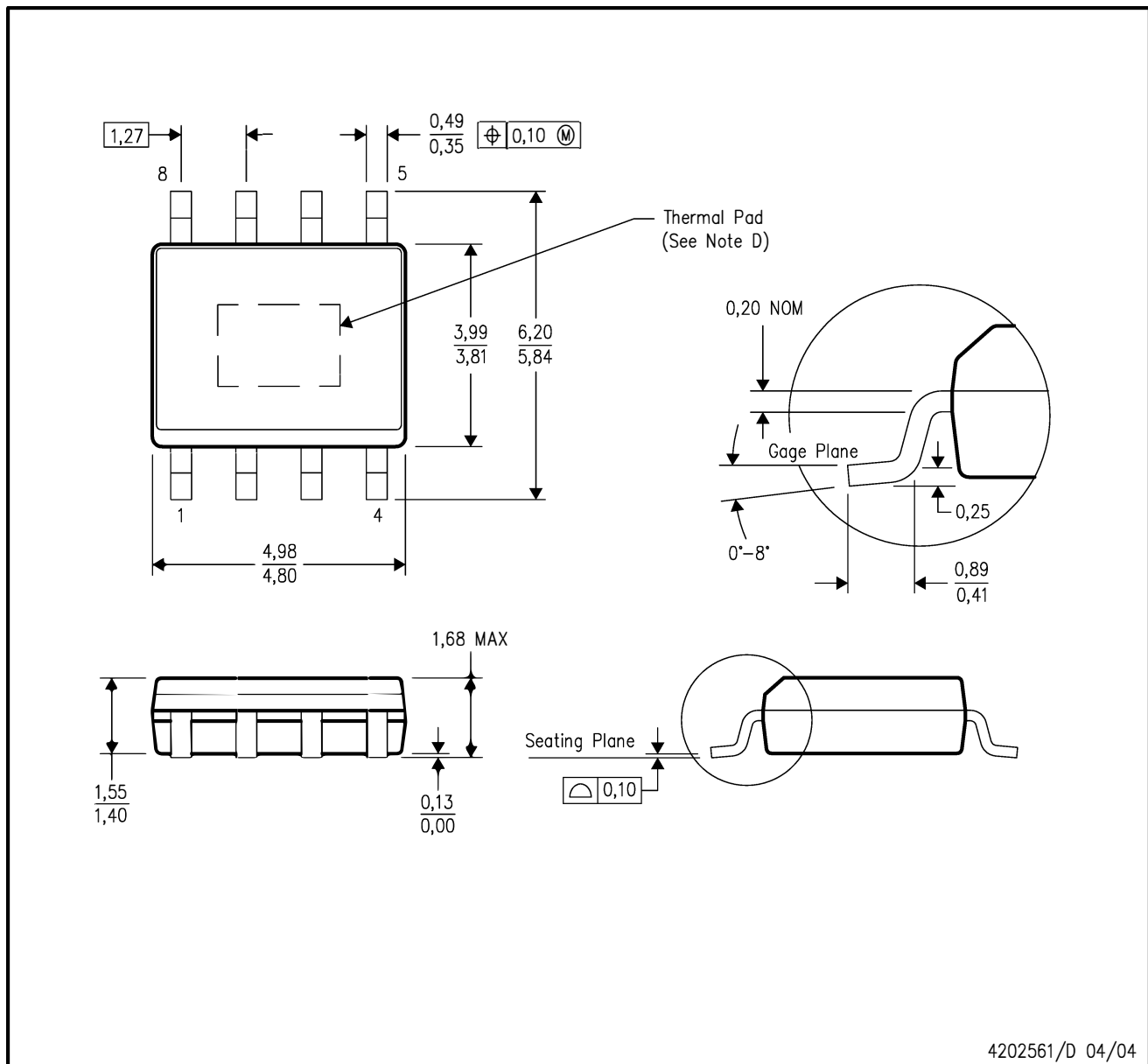

- NOTES:
- All linear dimensions are in millimeters.
  - This drawing is subject to change without notice.
  - Body dimensions do not include mold flash or protrusion not to exceed 0,15.
  - This package is designed to be soldered to a thermal pad on the board. Refer to Technical Brief, PowerPad Thermally Enhanced Package, Texas Instruments Literature No. SLMA002 for information regarding recommended board layout. This document is available at [www.ti.com](http://www.ti.com) <<http://www.ti.com>>.