

GENERAL DESCRIPTION

The SGM41562A and SGM41562B are highly integrated, I²C programmable, single-cell Li-Ion or Li-polymer battery chargers with system power path management. They are specifically designed for portable applications requiring minimum board space and small external components. The charging profile includes pre-charge, constant-current and constant-voltage phases. Several safety and protection features are included such as built-in safe charge timer to set maximum duration of charge and pre-charge, input voltage and current monitoring, internal (junction) and external (battery) temperature monitoring, input current limiting and load current limiting. SGM41562A can charge with a wide input voltage range of up to 18V compared to the SGM41562B which has 5.75V charging range, but the rest of their functions are the same.

The SGM41562A/B has 3 power ports: input power port (IN), battery port (BAT) and system or load port (SYS). The system is powered from the input whenever it is available. Input is typically a USB power source. If the input source is weak or removed, power source for the system will automatically switch to the battery. The voltage and currents from input and battery as power sources are continuously monitored to prevent battery damage due to excessive currents or over-discharge.

I²C serial interface is used to program the device functions and parameters or to read its status. 12 read/write or read only 8-bit registers (REG00 to REG0B) are accessible. A watchdog protection feature is also included. If this feature is enabled and there is no in time read/write activity or signal from the host, the device will reset the charging parameters to their defaults and recycles power to the system (turn off/on) that may reset the host.

The SGM41562A is capable of charging with input voltages as high as 18V but with higher input voltages, the chip temperature can easily rise up and thermal protection may stop charging if proper cooling is not considered. The SGM41562B goes into voltage protection state if V_{IN} > 6V. The input changes are continuously monitored and a system power recycle (SYS) may occur if the system does not respond to the input toggles.

The SGM41562A/B is available in a Green WLCSP-1.52×1.52-9B package. Device functionality and protection features are assured in the ambient temperature range from -40°C to +125°C. Charging parameters are guaranteed in 0°C to +55°C.

FEATURES

- Fully Autonomous Charger for Single-Cell Li-Ion and Li-Polymer Battery
- 21V Maximum Input Voltage Rating with Over-Voltage Protection
- ±0.6% Charging Voltage Accuracy
- 18V Maximum Operating Voltage (SGM41562A)
- 5.75V Maximum Operating Voltage (SGM41562B)
- I²C Interface for Parameters Setting/Status Reporting
- Fully Integrated Power Switches
- No External Blocking Diode Required
- Built-in Robust Charge Protections Including Battery Temperature Monitor and Programmable Timer
- Battery or PCB Over-Temperature Protection
- System Reset Function
- Built-in Battery Disconnection Function
- Thermal Limit Regulation on Chip
- Available in a Green WLCSP-1.52×1.52-9B Package

APPLICATIONS

Wearable Devices
IoT Gadgets

TYPICAL APPLICATION

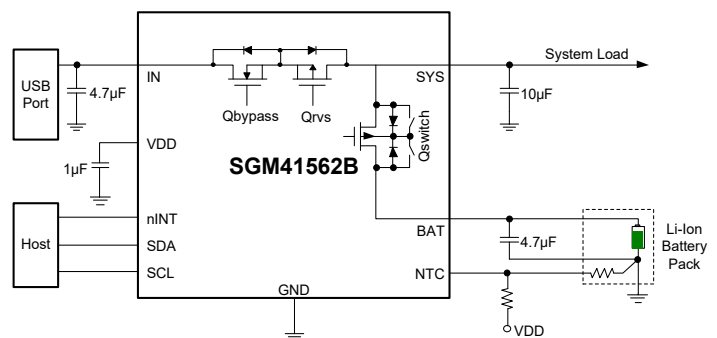

Figure 1. Typical Application Circuit

PACKAGE/ORDERING INFORMATION

MODEL	PACKAGE DESCRIPTION	SPECIFIED TEMPERATURE RANGE	ORDERING NUMBER	PACKAGE MARKING	PACKING OPTION
SGM41562A	WLCSP-1.52×1.52-9B	-40°C to +125°C	SGM41562AXG/TR	XXXXX RD0	Tape and Reel, 3000
SGM41562B	WLCSP-1.52×1.52-9B	-40°C to +125°C	SGM41562BXG/TR	XXXXX RD1	Tape and Reel, 3000

MARKING INFORMATION

NOTE: XXXXX = Date Code, Trace Code and Vendor Code.

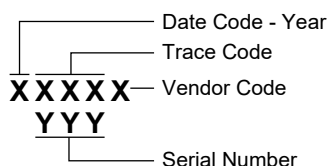

Green (RoHS & HSF): SG Micro Corp defines "Green" to mean Pb-Free (RoHS compatible) and free of halogen substances. If you have additional comments or questions, please contact your SGMICRO representative directly.

ABSOLUTE MAXIMUM RATINGS

IN	-0.3V to 21V
SYS	-0.3V to 5.3V (5.5V for 500µs)
All Other Pins to GND	-0.3V to 6V
I _{INCLAMP}	5mA
Package Thermal Resistance	
WLCSP-1.52×1.52-9B, θ _{JA}	95°C/W
Junction Temperature	+150°C
Storage Temperature Range	-65°C to +150°C
Lead Temperature (Soldering, 10s)	+260°C
ESD Susceptibility	
HBM	3000V
CDM	1000V

RECOMMENDED OPERATING CONDITIONS

Supply Voltage, V _{IN} ...	4.35V to 18V (SGM41562A, Charging)
.....	4.35V to 5.5V (SGM41562B, Charging)
(Over-Voltage Protection State, Continuous)	19V
I _{IN}	Up to 500mA
I _{BAT}	Up to 3.2A
I _{CHG}	Up to 456mA
V _{BAT_REG}	Up to 4.545V
Operating Junction Temperature Range	-40°C to +125°C

OVERSTRESS CAUTION

Stresses beyond those listed in Absolute Maximum Ratings may cause permanent damage to the device. Exposure to absolute maximum rating conditions for extended periods may affect reliability. Functional operation of the device at any conditions beyond those indicated in the Recommended Operating Conditions section is not implied.

ESD SENSITIVITY CAUTION

This integrated circuit can be damaged if ESD protections are not considered carefully. SGMICRO recommends that all integrated circuits be handled with appropriate precautions. Failure to observe proper handling and installation procedures can cause damage. ESD damage can range from subtle performance degradation to complete device failure. Precision integrated circuits may be more susceptible to damage because even small parametric changes could cause the device not to meet the published specifications.

DISCLAIMER

SG Micro Corp reserves the right to make any change in circuit design, or specifications without prior notice.

PIN CONFIGURATION

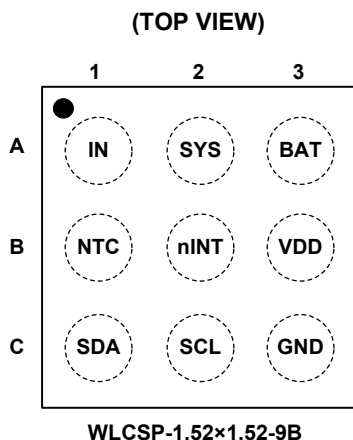

PIN DESCRIPTION

PIN	NAME	TYPE	FUNCTION
A1	IN	P	Input Power Pin. Place a minimum 2.2 μ F ceramic capacitor between IN pin and GND pin as close as possible to these pins.
A2	SYS	P	System Power Supply Output. Place a ceramic capacitor between SYS pin and GND pin as close as possible to these pins.
A3	BAT	P	Battery Positive Terminal Connection Pin. Place a ceramic capacitor between BAT pin and GND pin as close as possible to the device. Connect the negative battery terminal to power GND.
B1	NTC	AIO	Battery Temperature Sense Input. Connect a negative temperature coefficient thermistor between this pin and GND pin. NTC is usually placed in touch with battery pack. Hot-cold temperature window can be programmed by a resistor divider network placed between VDD to NTC to GND pins. Charging will suspend if NTC function is enabled and NTC pin voltage goes out of the V_{HOT} and V_{COLD} range.
B2	nINT	DIO	Interrupt Output. The nINT pin can send a charging status and fault interrupt signal to the host. nINT is also used to disconnect the system from the battery. Pull nINT pin from high to low for $> t_{RST_DGL}$ (16s default). The battery FET turns off and turns on again automatically after $> t_{RST_DUR}$ (4s default) regardless of the nINT state. Both t_{RST_DGL} and t_{RST_DUR} can be programmed via the I ² C interface.
B3	VDD	P	Internal Power Supply Pin. Connect a minimum 0.1 μ F decoupling ceramic capacitor from this pin to GND. External load current on this pin should not exceed 1mA.
C1	SDA	DIO	I ² C Bus Data. A 10k Ω pull-up to the logic-high rail should be used on SDA line.
C2	SCL	DI	I ² C Bus Clock. A 10k Ω pull-up to the logic-high rail should be used on SCL line.
C3	GND	—	Ground Pin of the Device.

NOTE:

AIO = Analog Input and Output; DI = Digital Input; DO = Digital Output; DIO = Digital Input and Output; P = Power.

ELECTRICAL CHARACTERISTICS

(T_A = +25°C, V_{IN} = 5V and V_{BAT} = 3.5V, unless otherwise noted.)

PARAMETER	SYMBOL	CONDITIONS	MIN	TYP	MAX	UNITS
Input Source and Battery Protection						
Input Under-Voltage Lockout Threshold	V _{IN_UVLO}	Input falling	3.44	3.65	3.88	V
V _{IN_UVLO} Threshold Hysteresis	V _{IN_UVLO_HYS}	Input rising		105		mV
Input Over-Voltage Protection Threshold	V _{IN_OVLO}	SGM41562A input rising threshold	18	19	21	V
		SGM41562B input rising threshold	5.75	6	6.27	
V _{IN_OVLO} Threshold Hysteresis	V _{IN_OVLO_HYS}			300		mV
Input Clamp Voltage	V _{IN_CLAMP}	Test for having 1.5mA clamp current	19.5	21		V
Input vs. Battery Voltage Headroom Threshold	V _{HDRM}	Input rising vs. battery		100		mV
V _{HDRM} Threshold Hysteresis	V _{HDRM_HYS}	Input vs. battery voltage headroom threshold hysteresis		150		mV
BAT Pin Input Voltage	V _{BAT}				4.5	V
Input Power Detection Time	t _{PWD}	Wait time before sending interrupt pulse for reporting input power new status	55	70	85	ms
nINT Output Pulse Duration	t _{INT_PULSE}			250		µs
Battery Under-Voltage Lockout Threshold	V _{BAT_UVLO}	V _{BAT} falling, VBAT_UVLO[2:0] = 000	2.30	2.40	2.66	V
		V _{BAT} falling, VBAT_UVLO[2:0] = 100	2.69	2.76	2.86	
		V _{BAT} falling, VBAT_UVLO[2:0] = 111	2.95	3.00	3.14	
Battery Under-Voltage Threshold Hysteresis	V _{BAT_UVLO_HYS}	V _{BAT_UVLO} = 2.76V		210		mV
Battery Over-Voltage Protection Threshold	V _{BAT_OVP}	Rising, higher than V _{BAT_REG}		100		mV
Power Path Management						
Regulated System Output Voltage Accuracy	V _{SYS_REG_ACC}	V _{IN} = 5.5V, R _{SYS} = 100Ω, I _{CHG} = 0A, V _{SYS_REG} [3:0] = 0000, V _{SYS_REG} = 4.2V	4.15	4.20	4.25	V
		V _{IN} = 5.5V, R _{SYS} = 100Ω, I _{CHG} = 0A, V _{SYS_REG} [3:0] = 1001, V _{SYS_REG} = 4.65V	4.59	4.65	4.71	
Input Current Limit	I _{IN_LIM}	I _{IN_LIM} [3:0] = 1111, I _{IN_LIM} = 500mA	320	500	620	mA
Input Minimum Voltage Regulation	V _{IN_MIN}	V _{IN_MIN} [3:0] = 0000, V _{IN_MIN} = 3.88V	3.58	3.88	4.20	V
		V _{IN_MIN} [3:0] = 1001, V _{IN_MIN} = 4.60V	4.27	4.60	4.96	
		V _{IN_MIN} [3:0] = 1111, V _{IN_MIN} = 5.08V	4.85	5.08	5.35	
IN to SYS Switch On-Resistance	R _{ON_Q1}	V _{IN} = 4.5V, I _{SYS} = 100mA		235		mΩ
Input Quiescent Current	I _{IN_Q}	V _{IN} = 5.5V, EN_HIZ = 0, CEB = 0, charge enable, I _{CHG} = 0A, I _{SYS} = 0A		80	100	µA
		V _{IN} = 5.5V, EN_HIZ = 0, CEB = 1, charge disabled		80	100	
Input Suspend Current	I _{IN_SUSP}	V _{IN} = 5.5V, EN_HIZ = 1, CEB = 0, charge enable		80	100	µA

ELECTRICAL CHARACTERISTICS (continued)

(T_A = +25°C, V_{IN} = 5V and V_{BAT} = 3.5V, unless otherwise noted.)

PARAMETER	SYMBOL	CONDITIONS	MIN	TYP	MAX	UNITS
Battery Quiescent Current	I _{BAT_Q}	V _{IN} = 5V, CEB = 0, I _{SYS} = 0A, V _{BAT} = 4.3V, charge complete		18		μA
		V _{IN} = GND, CEB = 1, VDD_GATE = 1, FET_DIS = 0, EN_SHIP_DGL[1:0] ≠ 11, I _{SYS} = 0A, V _{BAT} = 4.35V, disable external NTC circuit driving		10	70	
		V _{IN} = GND, CEB = 1, I _{SYS} = 0A, V _{BAT} = 4.35V, enable PCB OTP function, excluding the external NTC bias.		12		
		V _{IN} = GND, CEB = 1, I _{SYS} = 0A, V _{BAT} = 4.35V, enable PCB OTP function and watchdog, excluding the NTC bias.		28		
		V _{BAT} = 4.5V, IN is open or grounded, shipping mode		0.7	1.2	
Battery FET On-Resistance	R _{ON_Q2}	V _{IN} < 2V, V _{BAT} = 3.5V, I _{SYS} = 100mA		100		mΩ
Battery FET Discharge Current Limit (Refer to Histogram)	I _{DSCHG}	IDSCHG[3:0] = 0001, I _{DSCHG} = 400mA		400		mA
		IDSCHG[3:0] = 1001, I _{DSCHG} = 2000mA		2000		
Delay before Discharge Over Current Cut	t _{DSCHG_CUT}	Delay after discharge OC detection and before turning switch off		64		μs
Delay before Retry after Cut	t _{RETRY}	Turn on retry delay after OC turn off		800		μs
Ideal Diode Forward Voltage in Supplement Mode (BAT to SYS)	V _{FWD}	50mA discharge current		5		mV
Shipping Mode						
Enter to Shipping Mode Deglitch Delay Time after Programming the Shipping Mode	t _{SMEN_DGL}	FET_DIS is set from 0 to 1, EN_SHIP_DGL[1:0] = 00		1		s
Exit Shipping Mode Delay (Initiated by nINT pin or V _{IN} Plug-in)	t _{SMEX_DGL}	nINT pin is pulled low		2		s
Auto-Reset Mode						
Reset and Power Recycle by nINT Pin is Pull Down	t _{RST_DGL}	tRST_DGL[1:0] = 00		8		s
		tRST_DGL[1:0] = 10		16		
Battery FET Off-Time Duration after Reset	t _{RST_DUR}	tRST_DUR = 0		2		s
		tRST_DUR = 1		4		
Battery Charger						
Battery Charge Regulation Voltage	V _{BAT_REG}	VBAT_REG[5:0] = 101000, V _{BAT_REG} = 4.2V	4.175	4.200	4.225	V
		VBAT_REG[5:0] = 110100, V _{BAT_REG} = 4.38V	4.354	4.380	4.406	
		VBAT_REG[5:0] = 111111, V _{BAT_REG} = 4.545V	4.518	4.545	4.572	
Charge Current	I _{CC}	ICC[5:0] = 000000, I _{CC} = 8mA	5.5	8	9.8	mA
		ICC[5:0] = 001100, I _{CC} = 96mA	80	96	110	
		ICC[5:0] = 100000, I _{CC} = 264mA	235	264	305	
		ICC[5:0] = 111000, I _{CC} = 456mA	375	456	530	
Junction Temperature Regulation	T _{J_REG}	I ² C programmable range	60		120	°C
		T _{J_REG} [1:0] = 11, T _{J_REG} = 120°C		120		
Pre-Charge Current	I _{PRE}	ITERM[3:0] = 0101, I _{TERM} = I _{PRE} = 11mA		11		mA
		ITERM[3:0] = 1111, I _{TERM} = I _{PRE} = 31mA		31		

ELECTRICAL CHARACTERISTICS (continued)

(T_A = +25°C, V_{IN} = 5V and V_{BAT} = 3.5V, unless otherwise noted.)

PARAMETER	SYMBOL	CONDITIONS	MIN	TYP	MAX	UNITS
Charge Termination Current Threshold	I _{TERM}	ITERM[3:0] = 0000, I _{TERM} = 1mA	0.7	1	1.2	mA
		ITERM[3:0] = 0001, I _{TERM} = 3mA	1.8	3	4	
		ITERM[3:0] = 0101, I _{TERM} = 11mA	6.4	11	15	
Termination Deglitch Time	t _{TERM_DGL}			200		ms
Pre-Charge to Fast Charge Threshold	V _{BAT_PRE}	V _{BAT} Rising, V _{BAT_PRE} = 1, V _{BAT_PRE} = 3V	2.9	3	3.1	V
Pre-Charge to Fast Charge Threshold Hysteresis	V _{BAT_PRE_HYS}			90		mV
Battery Auto-Recharge Voltage Drop Threshold	V _{RECH}	Below V _{BAT_REG} , V _{RECH} = 0	110	135	155	mV
		Below V _{BAT_REG} , V _{RECH} = 1	210	240	275	
Battery Auto-Recharge Deglitch Time	t _{RECH_DGL}			200		ms
Thermal Protection						
Thermal Shutdown Threshold	T _{J_SHDN}			150		°C
Thermal Shutdown Hysteresis				20		°C
NTC Pin Output Current	I _{NTC}	CEB = 0, NTC = 3V	-200		200	nA
NTC Cold Temp Rising Threshold	V _{COLD}	As percentage of V _{DD}	63	65	67	%
NTC Cold Temp Rising Threshold Hysteresis				30		mV
NTC Hot Temp Falling Threshold	V _{HOT}	As percentage of V _{DD}	31	33	35	%
NTC Hot Temp Falling Threshold Hysteresis				70		mV
NTC Hot Temp Falling Threshold for PCB OTP	V _{HOT_PCB}	As percentage of V _{DD}	30	32	34	%
NTC Hot Temp Falling Threshold Hysteresis for PCB OTP				90		mV
Logic IO Pin Characteristics						
Low Logic Voltage Threshold	V _L				0.4	V
High Logic Voltage Threshold	V _H		1.4			V
I²C Interface (SDA, SCL)						
Input Low Logic Voltage Threshold	V _{IL}				0.4	V
Input High Logic Voltage Threshold	V _{IH}		1.4			V
Output Low Threshold Level	V _{OL}	I _{SINK} = 5mA			0.2	V
I ² C Clock Frequency	f _{SCL}				400	kHz
Clock Frequency and Watchdog Timer						
Watchdog Timer	t _{WDT}	WATCHDOG[1:0] = 11		160		s

TYPICAL PERFORMANCE CHARACTERISTICS

$T_A = +25^\circ\text{C}$, $V_{IN} = 5\text{V}$, $I_{IN} = 500\text{mA}$, $I_{CC} = 128\text{mA}$ and $V_{IN_MIN} = 4.6\text{V}$, unless otherwise noted.

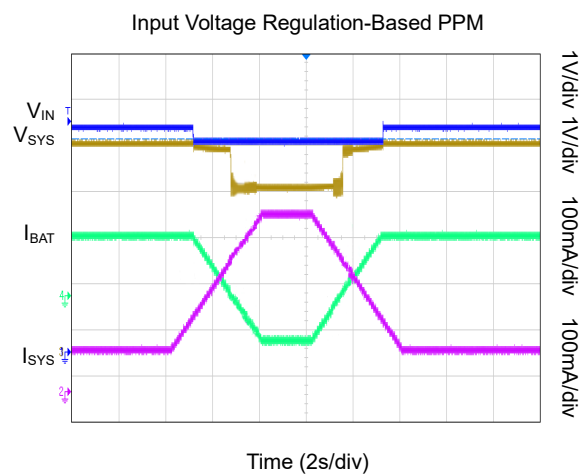
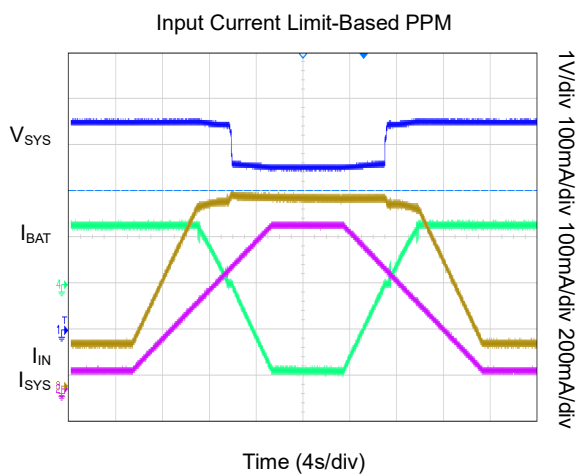
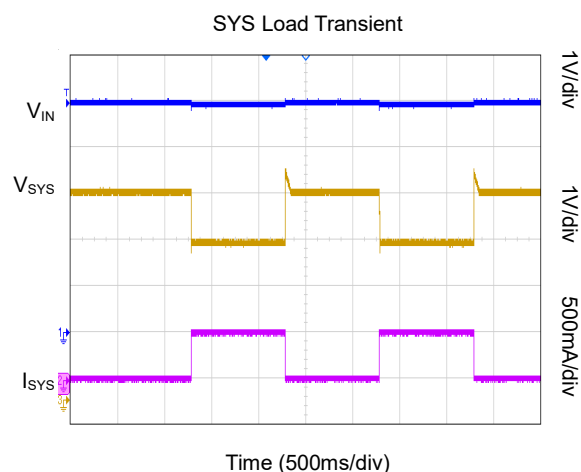
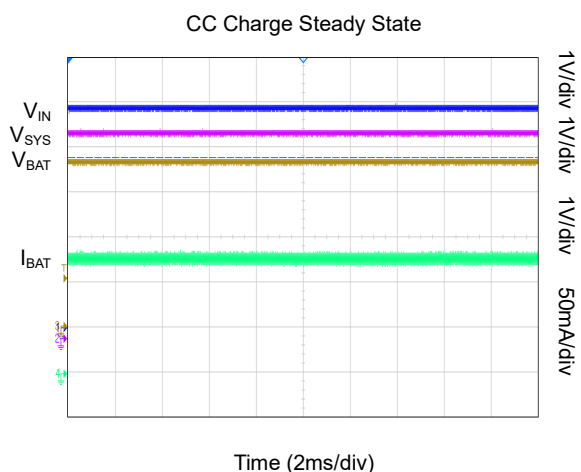
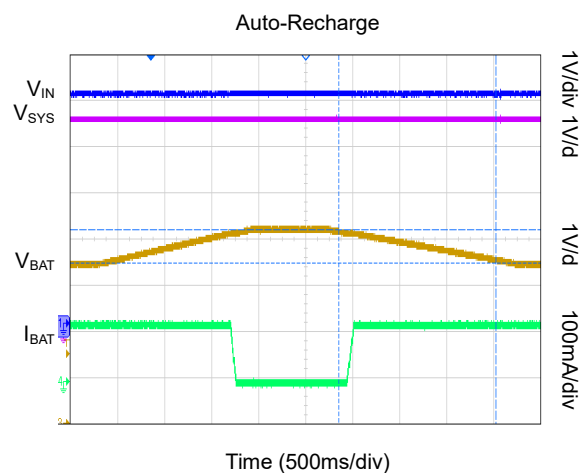
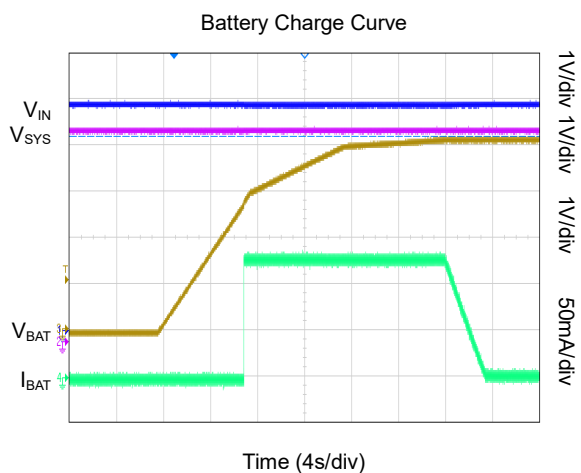

TYPICAL PERFORMANCE CHARACTERISTICS (continued)

$T_A = +25^\circ\text{C}$, $V_{IN} = 5\text{V}$, $I_{IN} = 500\text{mA}$, $I_{CC} = 128\text{mA}$ and $V_{IN_MIN} = 4.6\text{V}$, unless otherwise noted.

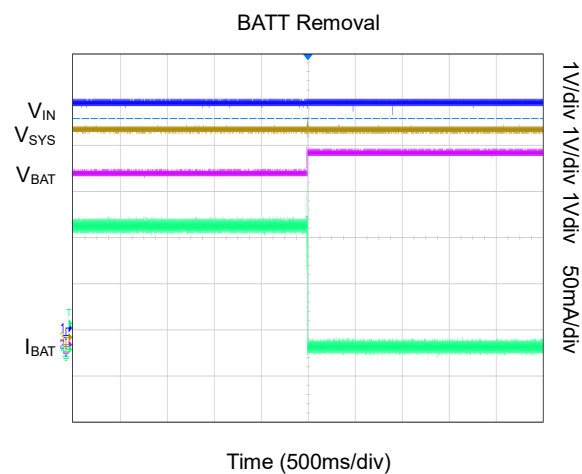
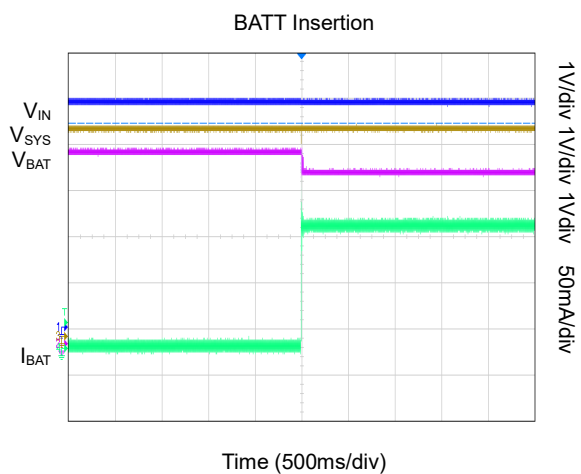
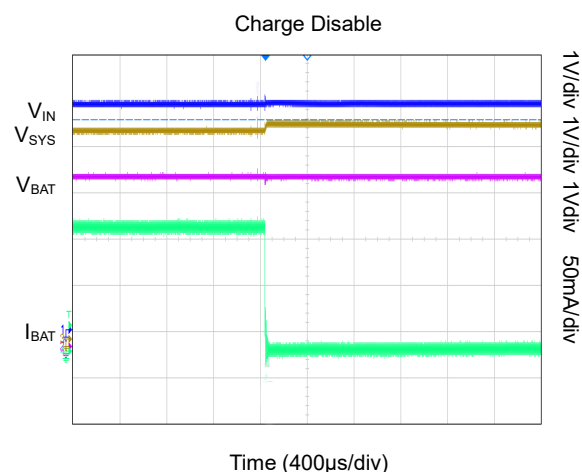
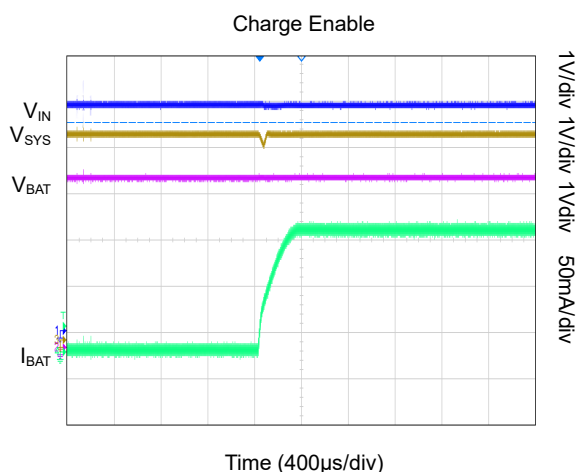
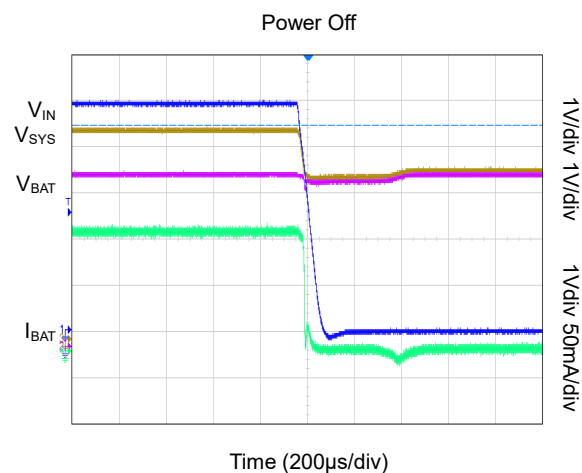
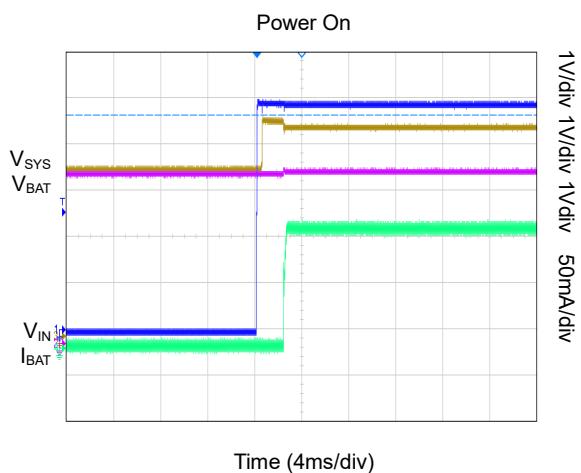

TYPICAL PERFORMANCE CHARACTERISTICS (continued)

$T_A = +25^\circ\text{C}$, $V_{IN} = 5\text{V}$, $I_{IN} = 500\text{mA}$, $I_{CC} = 128\text{mA}$ and $V_{IN_MIN} = 4.6\text{V}$, unless otherwise noted.

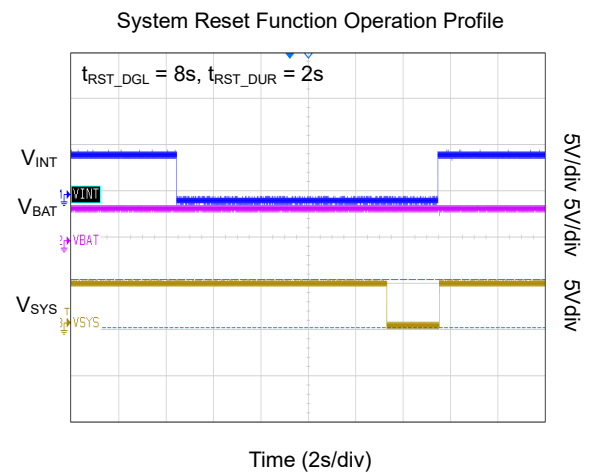
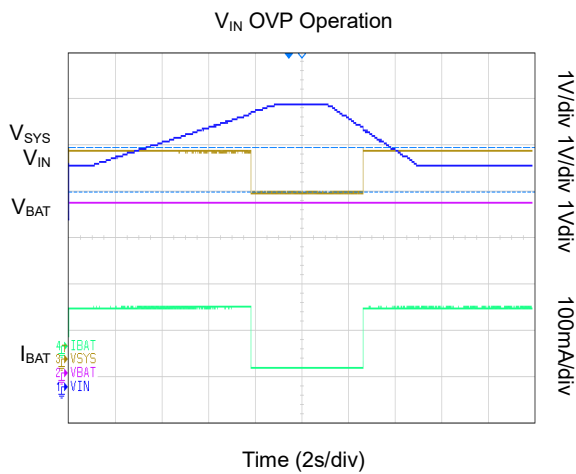
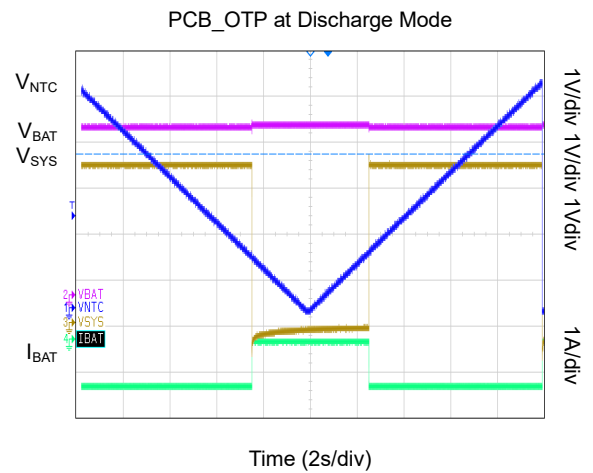
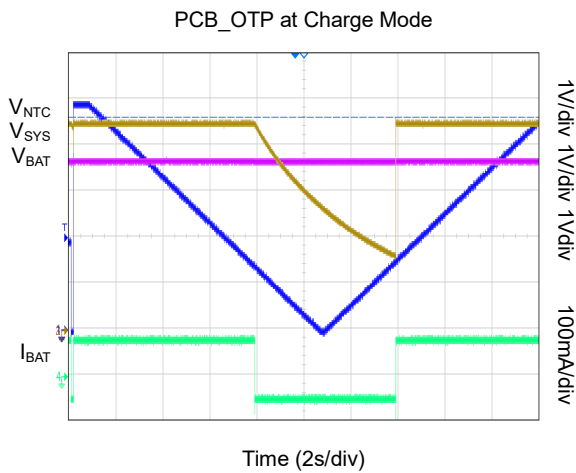
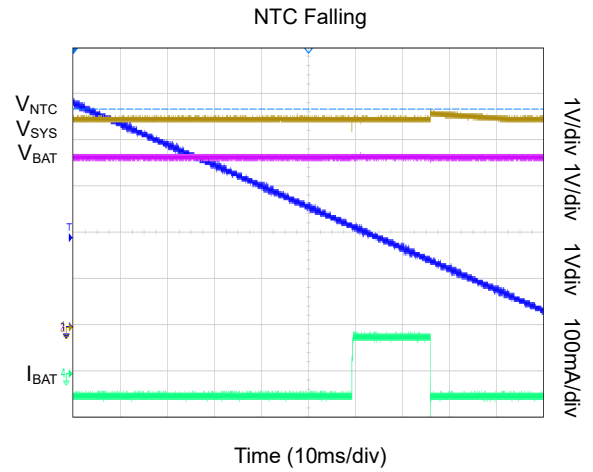
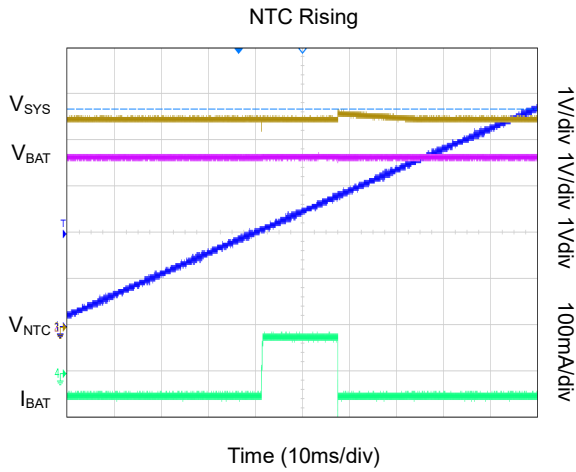

TYPICAL PERFORMANCE CHARACTERISTICS (continued)

$T_A = +25^\circ\text{C}$, $V_{IN} = 5\text{V}$, $I_{IN} = 500\text{mA}$, $I_{CC} = 128\text{mA}$ and $V_{IN_MIN} = 4.6\text{V}$, unless otherwise noted.

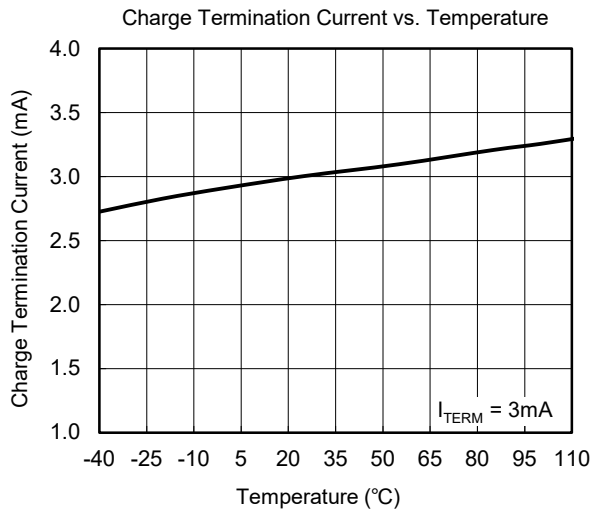
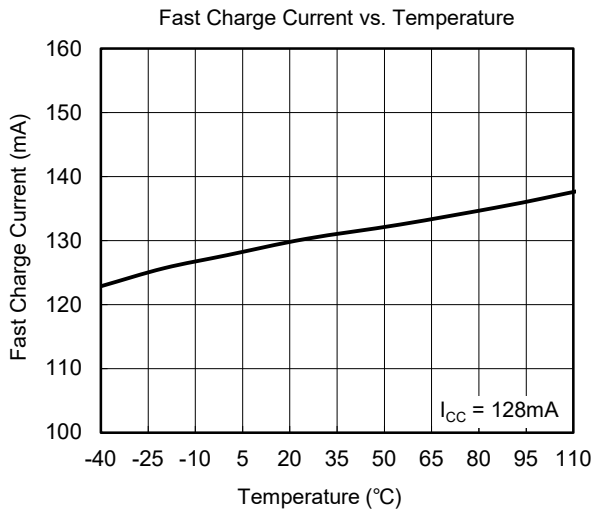
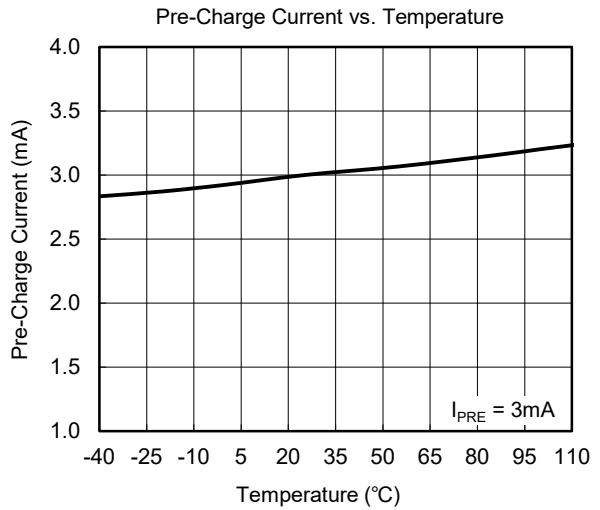
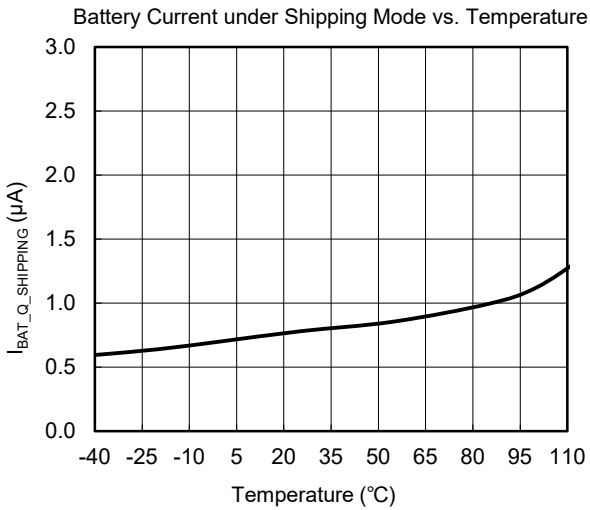
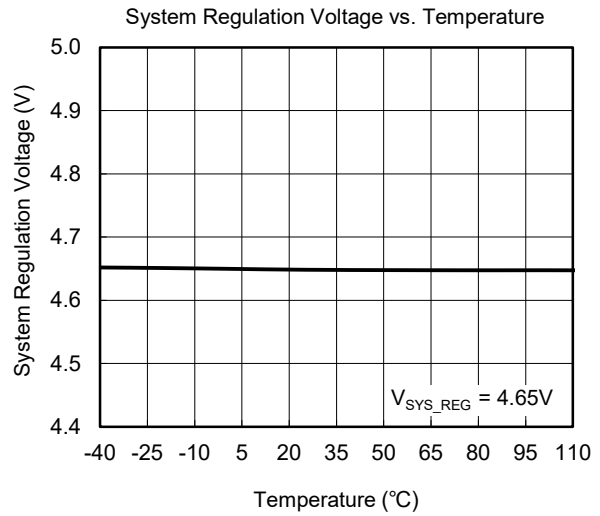
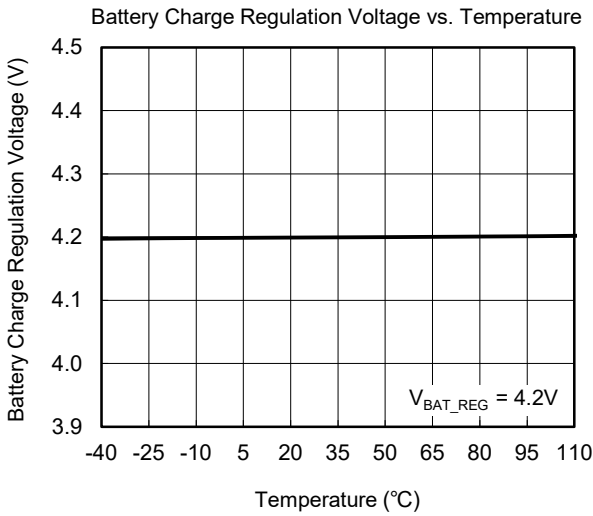

TYPICAL PERFORMANCE CHARACTERISTICS (continued)

$T_A = +25^\circ\text{C}$, $V_{IN} = 5\text{V}$, $I_{IN} = 500\text{mA}$, $I_{CC} = 128\text{mA}$ and $V_{IN_MIN} = 4.6\text{V}$, unless otherwise noted.

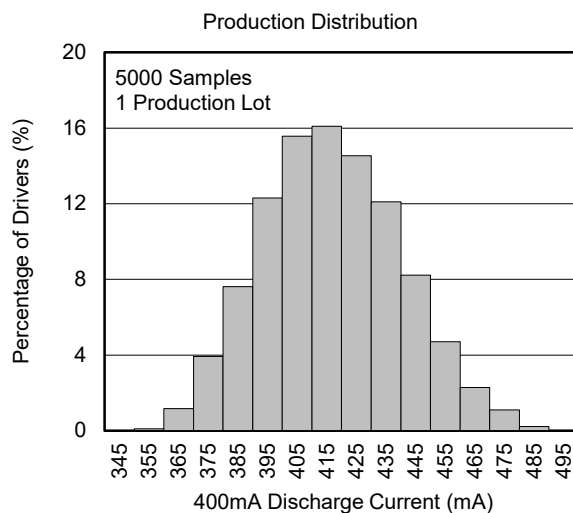
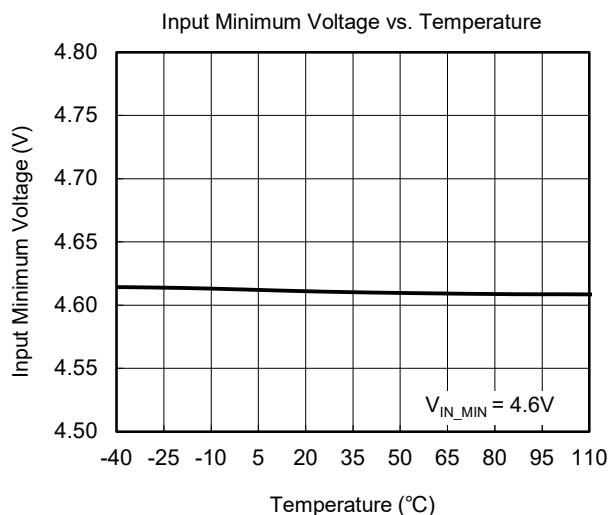
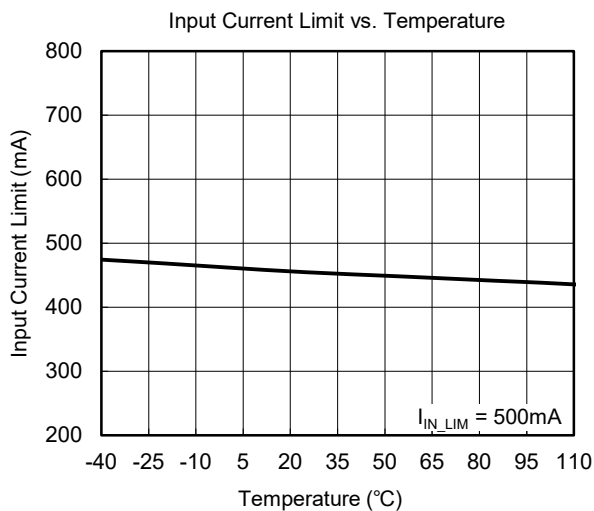
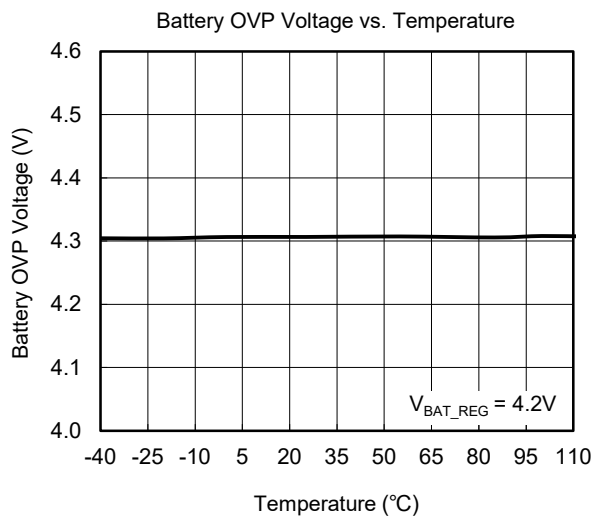

FUNCTIONAL BLOCK DIAGRAM

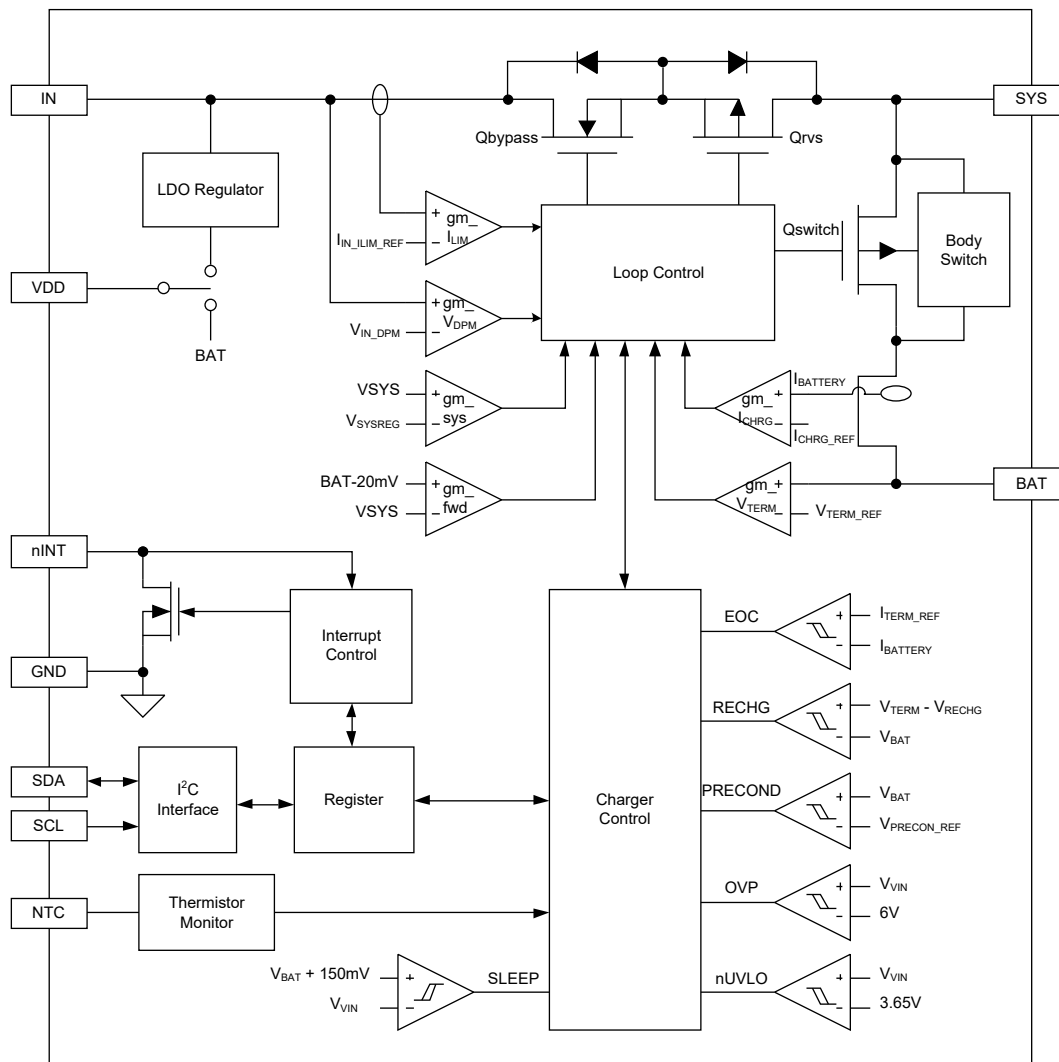

Figure 2. Functional Block Diagram

DETAILED DESCRIPTION

Introduction

The SGM41562A/B is a single-cell battery charger with power path management function for Li-Ion and Li-polymer batteries. The charge features include pre-charge, fast charge including constant-current mode (CCM) and constant-voltage mode (CVM), end-of-charge termination, auto-recharge, and a built-in safe charge timer. The safe charge timer is used to prevent over-charging or other issues if the host runs out of control.

A bypass switch between IN and SYS pins, and a battery switch between SYS and BAT pins are integrated to provide complete power path management (PPM). The switches have low on-resistances to minimize loss and heat. System load is primarily powered from the input when it is available, and the remaining input power is used to charge the battery if needed. When the input source is weak, the load is powered partially from the battery. This mode in which the battery provides the power deficit is called supplement mode. Battery will provide the full load power if input is removed or if V_{IN} is out of range. For battery charging, the power to the battery is regulated by the battery switch. To prevent faulty charge conditions, input voltage, input current, system voltage, chip temperature and external temperature (sensed by NTC) are continuously monitored during charge.

Figure 3 shows the power paths and key internal blocks of the device. The Qbypass switch regulates the voltage of the system and the internal charge circuit. The Qrvs switch acts as a near ideal blocking diode to prevent reverse power (or leakage) from the load (SYS pin) back to the input (IN pin). The Qswitch switch is responsible for battery charging regulation and connecting or disconnecting of the battery (BAT pin) to the system (SYS pin). The charge and discharge circuits in the Figure 3 that are connected to the IN and BAT pins have their own independent UVLO and power supply. The rest of the chip is powered by either IN or SYS pin, whichever has the higher voltage. The I/F interface (I²C communication and nINT) block is active whenever any of the power sources (IN or BAT pin) are available.

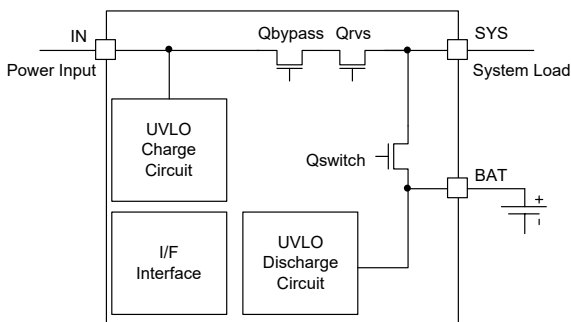

Figure 3. Power Path Management Structure

The chip has a watchdog timer as a protective feature against unexpected host malfunctions. When watchdog timer is enabled, it must be reset by host regularly to prevent watchdog timer overflow that results in a chip reset and power recycle. Watchdog reset is by writing into the watchdog register through I²C interface (I/F). If the watchdog is not reset on time, the power to the host will recycle.

The power fed to the SYS pin is recycled when watchdog times out, the host does not response to IN power input (when watchdog is forced on) or COLD_RESET bit is set to 1, to clear the running environment before system program upgrade or release from locked situations.

Input Detection

Figure 4 shows how the input voltage status is detected and affects the device function along with the relevant timings and nINT output signal updates. The device continuously monitors the input voltage at the IN node. The SYS node and charge circuit is only started and connected to the input when for a duration of t_{INI} , V_{IN} is within its normal range (above V_{IN_UVLO} and below V_{IN_OVLO}). Qbypass and Qrvs switches will turn off as soon as an input UVLO or OVLO is detected.

As shown in Figure 4 any input state is considered stable if it continuously stays in the same condition for a duration of t_{PWD} after which the device sends out a negative pulse to the nINT pin with a pulse width of t_{INT_PULSE} to inform the host about the input state change.

The watchdog timer WATCHDOG[1:0] register is set to 01 once the valid input is detected and when an INT pulse is asserted, which resumes its original setting when any writing to this device occurs. If the host does not clear the watchdog, power to the host is recycled for reset when watchdog runs time out.

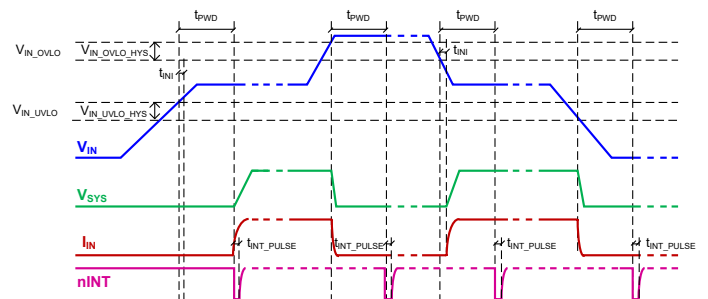

Figure 4. Input Power Detection and nINT Signaling Timings

DETAILED DESCRIPTION (continued)

Power Path Management

When the input voltage is normal and have enough headroom for powering the system ($V_{IN} > V_{IN_UVLO}$ and $V_{IN} - V_{SYS} > V_{HDRAM}$), the input power path will conduct and the device starts to power the system from input by setting the system voltage to V_{SYS_REG} . V_{SYS_REG} is selected by programming $VSYS_REG[3:0]$ register, the lower 4 bits of REG07 (also called system voltage register or $VSYS_REG[3:0]$ register). However, the actual system voltage (V_{SYS}) can be affected by the input voltage level, input current limit and battery voltage.

I^2C commands can directly control the power paths. Input path will be disconnected (high-impedance) by turning off Qbypass switch if the EN_HIZ bit is set to 1. If the battery is getting charge and Qswitch switch is on, it can also be disconnected by setting charge enable bit, set the CEB bit to 1 (turn off Qswitch switch in charge direction). The power path control bits are explained in Table 1. When these bits are clear, they have no effect.

Table 1. Switch Control by I^2C Interface

FETs	EN_HIZ = 1	CEB = 1
Qbypass	Off	X
Qswitch (Charging)	X	Off
Qswitch (Discharging)	X	X

NOTE: X = Don't Care.

Battery Charge Profile

Figure 5 shows the battery charge profile used in this device. The charge phases are explained below. Depending on the I^2C settings and the battery state of charge (SOC), some or all of the phases may be skipped or used to finish a complete charge cycle as explained below:

Pre-Charge: If the battery voltage is less than the pre-charge threshold (V_{BAT_PRE}), the battery is charged with the small pre-charge current (I_{PRE}). The pre-charge current value is the same as the termination current (I_{TERM}) that is programmed via bit D[3:0] of the REG03, also called $I_{TERM}[3:0]$.

Constant-Current Charge: When battery voltage is higher than V_{BAT_PRE} , and less than V_{BAT_REG} , it will be charged with a constant current. The constant-current value is determined by bit D[5:0] of the REG02 that is called $ICC[5:0]$ and a single scaling bit that if set, multiplies it by $\frac{1}{4}$. This bit is used for finer CC adjustment (CC_FINE bit in REG0A).

Constant-Voltage Charge: When the battery voltage reaches to the V_{BAT_REG} , the voltage is kept constant and the charge current down by battery will start to fall. The V_{BAT_REG} value is determined by bit D[7:2] of the REG04 that is also called $V_{BAT_REG}[5:0]$.

Charge Termination: A charge termination is recognized when the charge current drops to a small value represented by I_{TERM} . If the termination detection is enabled by setting the EN_TERM bit in REG05 D[4] to 1, then if the charge current (I_{CHG}) stays equal or lower than I_{TERM} for a period of t_{TERM_DGL} (termination deglitching time) the charge cycle is considered complete and charging current will be turned off and drop to zero. With no termination, the charge current will continue to drop. Note that a charge cycle is also considered complete and charging will be turned off, if the safe timer function runs out of time provided that the safe timer function is already enabled by setting EN_TIMER bit in REG05 D[3] to 1.

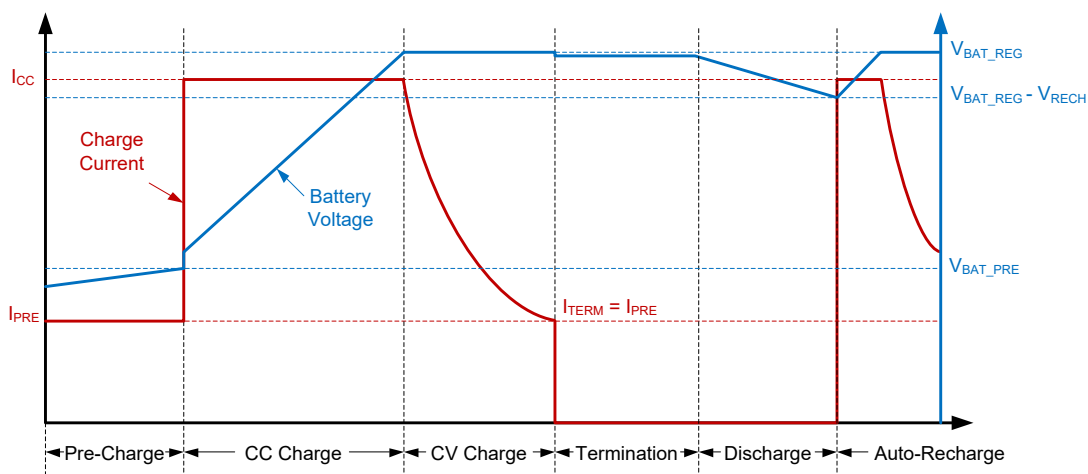

Figure 5. Battery Charge Profile

DETAILED DESCRIPTION (continued)

The charge status is updated to "charge complete" once the termination condition is detected. The charge current will be terminated when termination conditions are met and if the TERM_TMR bit is set to 0 (REG05 D[0] = 0); The charge will not terminate and current keeps decreasing if TERM_TMR bit is 1.

During the whole charging process, the actual charge current may fall below the set values due to the other regulations or controls such as dynamic power management (DPM) regulation caused by insufficient input voltage or current or due to thermal regulation. In thermal regulation the device reduces the power path currents to keep junction temperature below the programmed limit.

A new charge cycle starts when one of the following conditions occurs:

- ♦ The input power recycles (input on/off).
- ♦ Battery charging is enabled by I²C command.
- ♦ Auto-recharge kicks in due to battery charge state.

If all the following conditions are satisfied:

- ♦ No NTC thermistor temperature fault.
- ♦ No safety (charge) timer fault.
- ♦ No battery over voltage event.
- ♦ The Qswitch switch is not forced to turn off (e.g. CEB = 1).

Battery Over-Voltage Protection

SGM41562A/B has a built-in battery over-voltage protection limit. A battery over-voltage event is detected when battery voltage is higher than $V_{BAT_OVP} + V_{BAT_REG}$. When this event occurs, the charging is immediately suspended and a fault is asserted. The discharging path will be turned on if battery over-voltage condition does not clear and continues.

Input Current and Input Voltage Based Power Management

Usually the input source (typically USB) is not strong enough for all system power demands and a power management scheme is needed to keep the system voltage in desired level without over loading the source. Figure 6 shows the power management profile and explains how it is implemented in SGM41562A/B including the battery assist operation (supplement) when input source is not able to provide required power.

The input current is continuously monitored to make sure the input source maximum current limit specification is met. The total input current limit is programmable by I²C and is used to prevent over loading of the input source.

If the input source is weak and the programmed input current limit is higher than the effective capability of the source (like in a dynamic loading condition) the back-up power management will come in effect to prevent over loading of the input source. The back-up power management is based on limiting the input voltage drop to V_{IN_MIN} value (programmable). The voltage based dynamic power management (DPM) will regulate the input voltage to V_{IN_MIN} when the load is higher than the input current capacity. If input current and voltage limit are both reached, then the Qbypass switch (between IN and SYS pins) will regulate and limit the total power taken from the input. With the power limiting, if the system voltage drops to the minimum value of ($V_{SYS_REG} - 90mV$) or the input voltage falls below ($V_{IN} - 160mV$), the device will finally reduce the charge current to prevent further voltage drops.

The programmed V_{IN_MIN} must be at least 250mV higher than V_{BAT_REG} to assure stable operation of the regulator.

DETAILED DESCRIPTION (continued)

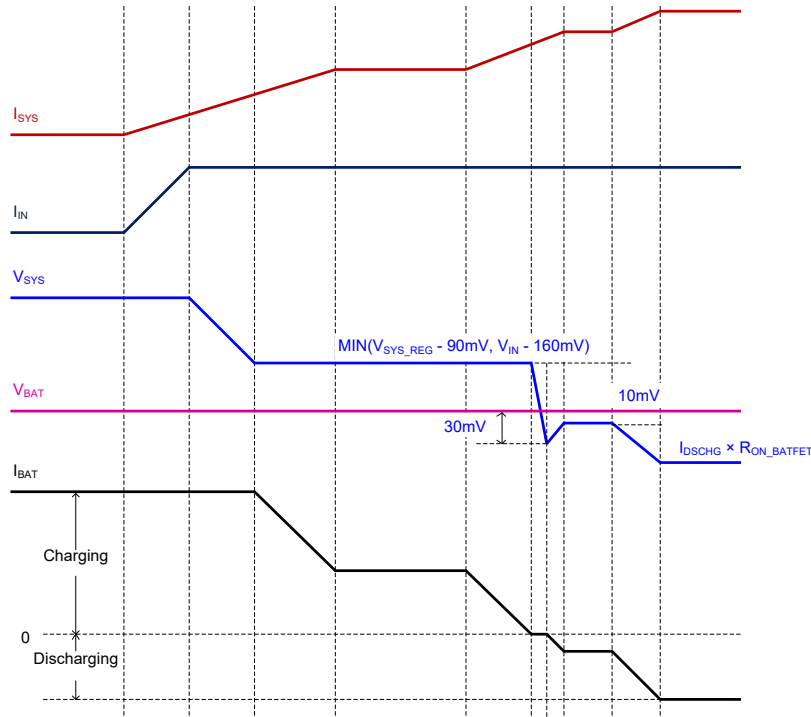

Figure 6. Dynamic Power Management and Battery Supplement Operation Profile

Battery Supplement Mode

As mentioned above, the DPM will reduce the charge current to keep the input current or voltage in regulation when source power is not sufficient for system demand. If the charge current is reduced to zero but still due to heavy system load the input source is overloaded and V_{SYS} continues to drop, then the battery will supply the deficit to assist the input source. This mode is called battery supplement mode in which the battery provides I_{DSCHG} as supplement current to the load. This mode starts when the system drop reaches to 30mV below the battery voltage. In this mode the Qswitch acts as a near ideal diode from battery to the system. The Qswitch switch is controlled to regulate and maintain the $V_{BAT} - V_{SYS}$ drop to a fixed 10mV value when $I_{DSCHG} \times R_{ON_BATFET}$ is less than 10mV. If $I_{DSCHG} \times R_{ON_BATFET}$ is larger than 10mV, the Qswitch switch is fully turned on to pass battery voltage to the system with minimum drop.

In the battery supplement mode the ideal diode mode will be disabled as soon as the system load decreases and V_{SYS} exceeds the $V_{BAT} + 20mV$ value.

When V_{IN} source is not available, the device operates in discharge mode (battery power) in which the Qswitch switch is always fully on to reduce the losses.

Battery Regulation Voltage

The battery voltage for the constant-voltage regulation phase (CV) is represented by V_{BAT_REG} .

Thermal Regulation and Shutdown

SGM41562A/B continuously monitors its internal junction temperature to avoid junction overheating while keeping the power delivery at its maximum. When the internal junction temperature reaches its programmable limit (T_{J_REG}), the device starts to reduce the charge current to prevent higher power dissipation. The thermal regulation limit is programmable to help adjusting the design for the thermal requirements in different applications. 4 different junction temperature regulation thresholds (default 120°C) can be chosen by programming the $TJ_REG[1:0]$ register. In particular, it is recommended that the junction temperature be set not lower than the ambient temperature at which the device charging behavior may occur.

The device fixed thermal shutdown limit (T_{J_SHDN}) is slightly higher than the highest programmable T_{J_REG} . If T_J rises above this limit, both Qbypass and Qswitch switches will turn off.

DETAILED DESCRIPTION (continued)

NTC Function and VDD Gating

The NTC pin is provided to sense the battery temperature using an NTC thermistor. Thermistors are usually included in the rechargeable battery packs to ensure safe operation by monitoring the battery temperature and making sure it is between hot and cold limits. To adjust the temperature limits for the device, two resistors (R_{T1} and R_{T2} in Figure 13) should be connected to NTC pin as a divider between VDD and GND pins. The thermistor itself is connected between NTC pin and GND. The voltage on the NTC pin is determined by all three resistors. This resistor divider along with the hot and cold limit voltages defined in the EC table determines the hot-cold operating window. Note that due to the negative temperature coefficient of NTC, when its voltage drops below V_{HOT} , it means the battery temperature is exceeding the hot limit. The NTC protection function can be disabled by clearing the EN_NTC bit to 0. The default settings for NTC function are the PCB OTP levels specified in EC table that can be change by I^2C as explained in Table 2.

Table 2. NTC Function Selection

I^2C Control		Function
EN_NTC	EN_PCB OTP	
0	don't care	Disable
1	1	NTC
1	0	PCB OTP

NTC function only works in charge mode. When NTC pin voltage falls out of the hot-cold window it means that the temperature is outside the safe operating range and results in a pause in charging and sets the fault bits. Charging will resume when the temperature falls back into the safe range.

If DIS_VDD bit is disabled and V_{IN} is removed, V_{DD} power turns off and becomes high-impedance leaving only R_{T2} in parallel with the NTC thermistor. If DIS_VDD bit is enabled, V_{DD} remains active. V_{DD} uses battery power if V_{IN} is removed.

With PCB OTP selected, if the NTC pin voltage is lower than the NTC hot threshold, Qbypass and Qswitch switches will turn off. The PCB OTP fault also will set the NTC_FAULT status bit to 1. The operation will resume when the NTC pin voltage goes back above the NTC hot threshold.

Safety Timer

Using an internal safety timer, SGM41562A/B is capable to limit the maximum duration of the pre-charge and charge periods to avoid extended charging cycles that may happen due to abnormal battery conditions. This protection can be disabled by I^2C . The safety timer starts counting if one of the following occurs:

- ◆ A new charge cycle is started.
- ◆ Write in REG01 D[3] bit: from 1 to 0 (charge enable)
- ◆ Write in REG05 D[3] bit: from 0 to 1 (safety timer enable)
- ◆ Write in REG02 D[7] bit: from 0 to 1 (software reset)
- ◆ Write in REG0A D[4] bit: from 0 to 1 (software power recycle)

The safety time limit is 1 hour for pre-charge condition in which the battery voltage stays lower than V_{BAT_PRE} and cannot go higher. For the charge phase the time limit is programmable through I^2C and the safety timer starts counting when the battery enters in constant-current charge mode or constant-voltage charge mode.

Host Mode and Default Mode

SGM41562A/B can operate in either default mode (with default parameters) or host mode (parameters programmed by host). It will go to the default mode if one of the following occurs:

- ◆ Input refresh with no battery connected.
- ◆ Re-insert battery with no input source connected.
- ◆ Device registers reset by writing 1 to REG_RST bit.
- ◆ Watchdog timer expiry.

Upon a power on reset, the device starts in default mode and in the same state as if watchdog timer expiration has occurred. In this mode all registers take their default values, including EN_HIZ = 0 and CEB = 1, that means the input power path is enabled and device is set to battery discharge mode. Note that by default the battery will not be charged after a reset.

When the device is in the host mode, watchdog function can be activated and works in both charge and discharge modes (Watchdog timer is independent of the charge safety timer). Watchdog timer can be enabled by programming a non-zero expiry time in its register, that is WATCHDOG[1:0] \neq 00. If watchdog timer is enabled, it must be reset regularly before it runs out of time by writing 1 to WD_RST bit in REG02. Otherwise the watchdog timer will expire and results in a power recycle to the system. Therefore, resetting the watchdog timer by host must happen in the intervals shorter than watchdog time limit. The power recycle is performed by turning off Qswitch and Qbypass for a duration of t_{RST_DUR} and then turning them on again. After watchdog timer expiration, all registers will reset to their default values and the device goes to the default mode.

To reduce the quiescent current during discharge mode, the watchdog timer can be turned off by setting the EN_WD_DISCHG bit to 0. If the WATCHDOG[1:0] is set to 00, the watchdog timer is disabled under charge and discharge modes independent of the EN_WD_DISCHG bit value.

DETAILED DESCRIPTION (continued)

Battery Discharge Function

If the battery is connected (V_{BAT} is above the V_{BAT_UVLO} threshold) and the input source is missing, the Qswitch turns fully on. The low on resistance of the Qswitch minimizes the conduction loss during discharge. The quiescent current of the device is as low as 12 μ A in this mode. By setting REG0A D[3] bit to 1, the Qswitch will stay on even if the rest of the internal blocks are turned off, to reduce the device quiescent current to less than 1.2 μ A. The low on-resistance and low quiescent current of the device extend the run time.

Over-Discharge Current Protection

The over-discharge current protection is effective in discharge mode and supplement mode. If the I_{BAT} exceeds discharge current limit value programmed in the REG03 D[7:4], the Qswitch turns off after a wait delay (t_{DSCHG_CUT}) and then resumes conducting after a retry delay time (t_{RETRY}).

When the battery voltage falls below the V_{BAT_UVLO} limit that is programmed in the REG01 D[2:0], the Qswitch turns off to prevent over discharging the battery.

If SWITCH_MODE bit (REG0A D[3]) is set to 1, the Qswitch is forced to remain on like a simple switch and the over-discharge is ignored during battery discharge. This bit will reset if power is re-applied to the input. It will also reset if the battery is connected or disconnected while power is applied to the input.

System Short Circuit Protection

If a short circuit (to GND) occurs on the load connected to SYS pin, the Qswitch disconnects the BAT to SYS path and the Qbypass limits the current flowing in the IN to SYS path. If the short circuit persists, the die temperature goes high and causes a thermal shutdown.

Interrupt to Host (nINT Pin)

The nINT output signal is provided to alert the host on power events. SGM41562A/B sends out a negative pulse (width = t_{INT_PULSE}) to nINT if any of the following events occurs:

- A good input source is detected ($UVLO < V_{IN} < OVLO$).
- UVLO or OVLO is detected (input).
- Charge completed.
- A charging status change.
- A fault record in REG09 occurs (input fault, thermal fault, safety timer fault, battery OVP fault or NTC fault).
- Watchdog expiration (WTD_FAULT in REG08 D[7]).

When one of the mentioned faults occurs, the relevant fault bit will latch in the register except for NTC fault bit that always reports the current status of the thermistor. A fault status bit is unlatched if the device quits that fault state. It will reset to 0 after the host reads the register if the bit is unlatched.

The assertion of nINT signal pulse can be masked for some of the events listed above when the corresponding mask control bits are set in REG06 D[4:0]. If a mask bit is set, and the event occurs, the nINT signals stays high.

The nINT pin is also used as an input to initiate a power recycle on the SYS output for example when a turn off/turn on is needed on the system when battery is not removable. This input is also used to exit the shipping mode that keeps the battery disconnected. The nINT pin is weakly pulled up internally to an unregulated low voltage that is not high enough for most logic devices. The weak and low voltage pull-up is used to avoid unexpected battery drain or leakage when the product is in shipping or is stocked for prolonged times (called shipping mode). The pull-up can be overdriven externally to higher appropriate logic voltages when it is in operation.

DETAILED DESCRIPTION (continued)

Battery Disconnection Function

When the battery is not removable, it's essential to disconnect the battery from the system to allow system power recycling or to put that in the shipping mode. It is performed by forcing the Qswitch to remain off by setting FET_DIS bit to 1. Table 3 explains how the SGM41562A/B can be programmed in shipping mode (or to do a power recycle on SYS) and how to exit the shipping mode. To exit shipping mode either the input power should be applied to IN port, or a low voltage (ground) should be applied to nINT pin for a short time (for example by holding a push bottom).

Table 3. Shipping Mode Control

Items	Enter Shipping Mode	Exit Shipping Mode	
	FET_DIS = 1	nINT Pin H to L for 2s	V _{IN} Plug-in
Qbypass	don't care	don't care	On
Qswitch (Charging)	Off	On	On (64ms Later)
Qswitch (Discharging)	Off	On	On (64ms Later)

The FET_DIS bit is used for battery disconnection control. If this bit is set to 1, the device enters shipping mode after a delay time, which can be programmed by EN_SHIP_DGL[1:0]. After the delay the Qswitch turns off and the FET_DIS bit resets to 0. The device wakes up from shipping mode by pulling down nINT pin or detecting an acceptable voltage on the IN pin. The device exits from shipping mode 2 seconds after pulling nINT pin down or 64ms after detecting an acceptable V_{IN}. For the application of nINT pulled down to a low voltage in the shipping mode, EN_SHIP_DGL[1:0] must keep default value.

System power can be recycled by turning off the Qswitch and Qbypass if nINT pin is pulled low for a duration of more than t_{RST_DGL}. It is the time delay to avoid noise and glitches or to hold a push bottom. The t_{RST_DGL} time is programmed by tRST_DGL[1:0] in REG01. The off state lasts for a duration of t_{RST_DUR} which can be programmed via tRST_DUR in REG01. After this time the Qswitch and/or Qbypass will be automatically turned on and the system is powered again. During the off period, the nINT pin is biased to a lower voltage.

The waveforms of power recycling are shown in Figure 7.

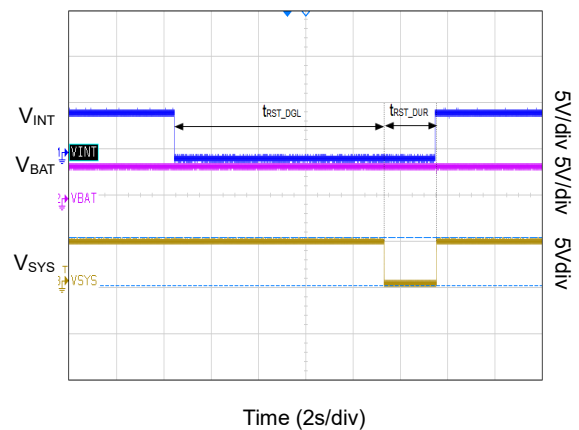

Figure 7. Power Recycling Waveforms

REGISTER MAP

All registers are 8-bit and individual bits are named from D[0] (LSB) to D[7] (MSB).

I²C Slave Address is: 03H

R/W: Read/Write bit(s).
R: Read only bit(s).
PORV: Power-On-Reset value.
n: Parameter code formed by the bits as an unsigned binary number.

REG00

Register address: 0x00; R/W

PORV = 10011111

Table 4. REG00 Register Details

BITS	BIT NAME	DESCRIPTION	COMMENT	PORV	TYPE	RESET BY
D[7:4]	VIN_MIN[3:0]	VIN_MIN[3] 1 = 640mV	Minimum Input Voltage Limit (n: 4 bits): = 3.88 + 0.08n (V) Offset: 3.88V Range: 3.88V (0000) - 5.08V (1111) Default: 4.60V (1001)	1	R/W	REG_RST
		VIN_MIN[2] 1 = 320mV		0	R/W	REG_RST
		VIN_MIN[1] 1 = 160mV		0	R/W	REG_RST
		VIN_MIN[0] 1 = 80mV		1	R/W	REG_RST
D[3:0]	IIN_LIM[3:0]	IIN_LIM[3] 1 = 240mA	Input Current Limit (n: 4 bits): = 50 + 30n (mA) Offset: 50mA Range: 50mA (0000) - 500mA (1111) Default: 500mA (1111)	1	R/W	REG_RST
		IIN_LIM[2] 1 = 120mA		1	R/W	REG_RST
		IIN_LIM[1] 1 = 60mA		1	R/W	REG_RST
		IIN_LIM[0] 1 = 30mA		1	R/W	REG_RST

REG01

Register address: 0x01; R/W

PORV = 10101100

Table 5. REG01 Register Details

BITS	BIT NAME	DESCRIPTION	COMMENT	PORV	TYPE	RESET BY
D[7:6]	tRST_DGL[1:0]	00 = 8s 01 = 12s 10 = 16s (default) 11 = 20s	nINT Pull-Down Period to Disconnect the Battery (n: 2 bits): = 8s + 4n (seconds)	1	R/W	REG_RST or Watchdog
				0	R/W	REG_RST or Watchdog
D[5]	tRST_DUR	0 = 2s 1 = 4s (default)	Battery FET off-time duration after reset. The Qbypass and Qswitch off-time before auto turn-on.	1	R/W	REG_RST or Watchdog
D[4]	EN_HIZ	HIZ Mode Enable 0 = Disable (default) 1 = Enable	Control Qbypass switch. Default: disable (0) or switch on Note: The EN_HIZ bit only controls the on and off of the Qbypass.	0	R/W	REG_RST or Watchdog
D[3]	CEB	Setting Charge Enable 0 = Charge Enable 1 = Charge Disabled (default)	Charge enable/disable Qswitch configuration. Default: charge disabled (1) or Qswitch off	1	R/W	REG_RST or Watchdog
D[2:0]	VBAT_UVLO[2:0]	VBAT_UVLO[2] 1 = 360mV	Battery UVLO Threshold Value (n: 3 bits): = 2.4V + 0.09n (V) Offset: 2.4V Range: 2.4V (000) - 3.03V (111) Default: 2.76V (100)	1	R/W	REG_RST or Watchdog
		VBAT_UVLO[1] 1 = 180mV		0	R/W	REG_RST or Watchdog
		VBAT_UVLO[0] 1 = 90mV		0	R/W	REG_RST or Watchdog

REGISTER MAP (continued)

REG02

Register address: 0x02; R/W

PORV = 00001111

Table 6. REG02 Register Details

BITS	BIT NAME	DESCRIPTION	COMMENT	PORV	TYPE	RESET BY
D[7]	REG_RST	Software Reset 0 = Keep Current Setting (default) 1 = Reset	If set, will reset most parameters to default. (as explained in the last column of register map tables)	0	R/W	REG_RST
D[6]	WD_RST	I ² C Watchdog Timer Reset 0 = Normal (default) 1 = Reset	If set, will reset watchdog timer.	0	R/W	REG_RST or Watchdog
D[5:0]	ICC[5:0]	ICC[5] 1 = 256mA	Fast Charge Current Value (CC Mode) (n: 5 bits): = 8mA + 8n (mA) (n ≤ 56)	0	R/W	REG_RST or Watchdog
		ICC[4] 1 = 128mA		0	R/W	REG_RST or Watchdog
		ICC[3] 1 = 64mA	Offset: 8mA Range: 8mA (000000) - 456mA (111000) Default: 128mA (001111) Note: Values above 56D = 111000 (456mA) are clamped to 56D = 111000 (456mA).	1	R/W	REG_RST or Watchdog
		ICC[2] 1 = 32mA		1	R/W	REG_RST or Watchdog
		ICC[1] 1 = 16mA		1	R/W	REG_RST or Watchdog
		ICC[0] 1 = 8mA		1	R/W	REG_RST or Watchdog

REG03

Register address: 0x03; R/W

PORV = 10010001

Table 7. REG03 Register Details

BITS	BIT NAME	DESCRIPTION	COMMENT	PORV	TYPE	RESET BY
D[7:4]	IDSCHG[3:0]	IDSCHG[3] 1 = 1600mA	BAT to SYS Discharge Current Limit Value (n: 4 bits): = 200mA + 200n (mA), n ≠ 0 Offset: 200mA Valid Range: 400mA (0001) - 3.2A (1111) Default: 2000mA (1001)	1	R/W	REG_RST or Watchdog
		IDSCHG[2] 1 = 800mA		0	R/W	REG_RST or Watchdog
		IDSCHG[1] 1 = 400mA		0	R/W	REG_RST or Watchdog
		IDSCHG[0] 1 = 200mA		1	R/W	REG_RST or Watchdog
D[3:0]	ITERM[3:0]	ITERM[3] 1 = 16mA	Charge Termination Current Value (n: 4 bits): = 1mA + 2n (mA) Offset: 1mA Range: 1mA (0000) - 31mA (1111) Default: 3mA (0001)	0	R/W	REG_RST or Watchdog
		ITERM[2] 1 = 8mA		0	R/W	REG_RST or Watchdog
		ITERM[1] 1 = 4mA		0	R/W	REG_RST or Watchdog
		ITERM[0] 1 = 2mA		1	R/W	REG_RST or Watchdog

REGISTER MAP (continued)

REG04

Register address: 0x04; R/W

PORV = 10100011

Table 8. REG04 Register Details

BITS	BIT NAME	DESCRIPTION	COMMENT	PORV	TYPE	RESET BY
D[7:2]	VBAT_REG[5:0]	VBAT_REG[5] 1 = 480mV	Battery Charge Regulation Voltage Value (CV Mode) (n: 6 bits): = 3.6V + 0.015n (V) Offset: 3.60V Range: 3.60V (000000) - 4.545V (111111) Default: 4.2V (101000)	1	R/W	REG_RST or Watchdog
		VBAT_REG[4] 1 = 240mV		0	R/W	REG_RST or Watchdog
		VBAT_REG[3] 1 = 120mV		1	R/W	REG_RST or Watchdog
		VBAT_REG[2] 1 = 60mV		0	R/W	REG_RST or Watchdog
		VBAT_REG[1] 1 = 30mV		0	R/W	REG_RST or Watchdog
		VBAT_REG[0] 1 = 15mV		0	R/W	REG_RST or Watchdog
D[1]	VBAT_PRE	Pre-Charge to Fast Charge Threshold 0 = 2.8V 1 = 3.0V (default)		1	R/W	REG_RST or Watchdog
D[0]	VRECH	Battery Recharge Threshold 0 = 100mV 1 = 200mV (default)	Offset below VBAT_REG.	1	R/W	REG_RST or Watchdog

REG05

Register address: 0x05; R/W

PORV = 01111010

Table 9. REG05 Register Details

BITS	BIT NAME	DESCRIPTION	COMMENT	PORV	TYPE	RESET BY
D[7]	EN_WD_DISCHG	Watchdog Control 0 = Disable (default) 1 = Enable	Watchdog control in discharge mode.	0	R/W	REG_RST
D[6:5]	WATCHDOG[1:0]	Watchdog Timer 00 = Disable timer 01 = 40s 10 = 80s 11 = 160s (default)	If WATCHDOG[1:0] = 00, then watchdog timer is disabled no matter EN_WD_DISCHG is set or not.	1	R/W	REG_RST
				1	R/W	REG_RST
D[4]	EN_TERM	Termination Control 0 = Disable 1 = Enable (default)	Use termination or not.	1	R/W	REG_RST or Watchdog
D[3]	EN_TIMER	Safety Timer Control 0 = Disable 1 = Enable (default)	Charge safety timer enable/disable setting.	1	R/W	REG_RST or Watchdog
D[2:1]	CHG_TMR[1:0]	Charge Timer 00 = 3hrs 01 = 5hrs (default) 10 = 8hrs 11 = 12hr		0	R/W	REG_RST or Watchdog
				1	R/W	REG_RST or Watchdog
D[0]	TERM_TMR	Termination Timer Control 0 = Disable (default) 1 = Enable	When TERM_TMR is enabled, the device will not suspend the charge current after charge termination.	0	R/W	REG_RST or Watchdog

REGISTER MAP (continued)

REG06

Register address: 0x06; R/W

PORV = 11000000

Table 10. REG06 Register Details

BITS	BIT NAME	DESCRIPTION	COMMENT	POR	TYPE	RESET BY
D[7]	EN_NTC	NTC Control 0 = Disable 1 = Enable (default)		1	R/W	REG_RST or Watchdog
D[6]	TMR2X_EN	Enable Half Clock Rate Safety Timer 0 = Disable. 1 = Enable 2× extended safety timer during PPM. (default)		1	R/W	REG_RST or Watchdog
D[5]	FET_DIS	0 = Enable (default) 1 = Disable	Qswitch control for shipping mode and system power recycle. Note: The FET_DIS bit controls the on and off of the Qswitch in both charging and discharging.	0	R/W	REG_RST
D[4]	PG_INT_CTL	0 = On (default) 1 = Off		0	R/W	REG_RST or Watchdog
D[3]	EOC_INT_CTL	Charge Completed INT Mask Control 0 = On (default) 1 = Off		0	R/W	REG_RST or Watchdog
D[2]	CHG_STATUS_ INT_CTL	Charging Status Change INT Mask Control 0 = On (default) 1 = Off	Charging statuses are: not charging, pre-charge and charge.	0	R/W	REG_RST or Watchdog
D[1]	NTC_INT_CTL	0 = On (default) 1 = Off		0	R/W	REG_RST or Watchdog
D[0]	BATOVP_INT_CTL	0 = On (default) 1 = Off		0	R/W	REG_RST or Watchdog

REG07

Register address: 0x07; R/W

PORV = 00110111

Table 11. REG07 Register Details

BITS	BIT NAME	DESCRIPTION	COMMENT	PORV	TYPE	RESET BY
D[7]	EN_PCB_OTP	PCB OTP Enable 0 = Enable (default) 1 = Disable		0	R/W	REG_RST or Watchdog
D[6]	EN_VINLOOP	0 = Enable (default) 1 = Disable		0	R/W	REG_RST or Watchdog
D[5:4]	TJ_REG[1:0]	Thermal Regulation Threshold 00 = 60°C 01 = 80°C 10 = 100°C 11 = 120°C (default)		1	R/W	REG_RST or Watchdog
				1	R/W	REG_RST or Watchdog
D[3:0]	VSYS_REG[3:0]	VSYS_REG[3] 1 = 400mV	System Regulation Voltage Value: = 4.2V + 0.05n (V) (n: 4 bits)	0	R/W	REG_RST
		VSYS_REG[2] 1 = 200mV	Offset: 4.2V	1	R/W	REG_RST
		VSYS_REG[1] 1 = 100mV	Range: 4.2V (0000) - 4.95V (1111) Default: 4.55V (0111)	1	R/W	REG_RST
		VSYS_REG[0] 1 = 50mV		1	R/W	REG_RST

REGISTER MAP (continued)

REG08

Register address: 0x08; R and R/W

PORV = 00000000

Table 12. REG08 Register Details

BITS	BIT NAME	DESCRIPTION	PORV	TYPE	RESET BY
D[7]	WTD_FAULT	Watchdog Expiration 0 = Normal (default) 1 = Watchdog Timer Expiration	0	R	NA
D[6]	IIN_LIM_REL	Input Current Limit Release 0 = Disable (default) 1 = Enable	0	R/W	REG_RST or Watchdog
D[5]	IIN_LIM_ADD200	Add 200mA to Input Current Limit 0 = Disable (default) 1 = Enable	0	R/W	REG_RST or Watchdog
D[4:3]	CHG_STAT[1:0]	Charging Status 00 = Not Charging (default) 01 = Pre-Charge 10 = Charge 11 = Charge Done	0	R	NA
			0	R	NA
D[2]	PPM_STAT	Device in Power Path Management Mode (PPM) 0 = No PPM (default) 1 = IN PPM	0	R	NA
D[1]	PG_STAT	Input Power (IN) Status 0 = Power Fail (default) 1 = Power Good	0	R	NA
D[0]	THERM_STAT	Thermal Regulation Status 0 = No Thermal Regulation (default) 1 = In Thermal Regulation	0	R	NA

REG09

Register address: 0x09; R and R/W

PORV = 00000000

Table 13. REG09 Register Details

BITS	BIT NAME	DESCRIPTION	PORV	TYPE	RESET BY
D[7:6]	EN_SHIP_DGL [1:0]	Enter Shipping Mode Deglitch Time 00 = 1s (default) 01 = 2s 10 = 4s 11 = 8s	0	R/W	REG_RST
			0	R/W	REG_RST
D[5]	VIN_FAULT	Input VIN Fault Status 0 = Normal (default) 1 = Input Fault (OVP or bad source)	0	R	NA
D[4]	THERM_SD	Thermal Shutdown Fault Status 0 = Normal (default) 1 = Thermal Shutdown	0	R	NA
D[3]	BAT_FAULT	Battery Over-Voltage Fault Status 0 = Normal (default) 1 = Battery OVP	0	R	NA
D[2]	STMR_FAULT	Safety Timer Expiration Fault Status 0 = Normal (default) 1 = Safety Timer Expiration	0	R	NA
D[1]	NTC_FAULT[1]	NTC Exceeding Hot Level 0 = Normal (default) 1 = NTC Hot	0	R	NA
D[0]	NTC_FAULT[0]	NTC Exceeding Cold Level 0 = Normal (default) 1 = NTC Cold	0	R	NA

REGISTER MAP (continued)

REG0A

Register address: 0x0A; R and R/W

PORV = 01100000

Table 14. REG0A Register Details

BITS	BIT NAME	DESCRIPTION	COMMENT	PORV	TYPE	RESET BY
D[7:5]	ADDR[2:0]	Slave Address 001 = 01H 010 = 02H 011 = 03H (default) 100 = 04H 101 = 05H 110 = 06H 111 = 07H		0	R	NA
				1	R	NA
				1	R	NA
D[4]	COLD_RESET	Software Power Recycle 0 = No Action (default) 1 = Power Recycle Reset	Causes a system power recycles if set to 1. Automatically clears after power recycle.	0	R/W	NA
D[3]	SWITCH_MODE	0 = Normal Power Path (default) 1 = Qswitch Forced On	Effective in battery discharge mode only. When Qswitch is forced on, there is no current and voltage limit because the internal circuits are shut down for lower consumption.	0	R/W	NA
D[2]	DIS_VDD	0 = Enable Battery Power (default) 1 = Disable Battery Power	If set to 1, V _{DD} becomes high-impedance when V _{IN} is removed. If the PCB OTP of NTC function is selected, the DIS_VDD bit setting is invalid.	0	R/W	NA
D[1]	DIS_VINOVP	0 = Enable (default) 1 = Disable	Disables over-voltage lockout detection of V _{IN} if set to 1.	0	R/W	NA
D[0]	CC_FINE	0 = Normal Scale (default) 1 = Fine Scale	If set to 1, the programmed charge current in ICC[5:0] is weighted to ¼.	0	R/W	NA

REG0B

Register address: 0x0B; R

PORV = 00000010 (SGM41562A)

PORV = 00000000 (SGM41562B)

Table 15. REG0B Register Details

BITS	BITNAME	DESCRIPTION	COMMENT	PORV	TYPE	RESET BY
D[7:0]	ID[7:0]	Device ID	SGM41562A = 00000010 SGM41562B = 00000000		R	NA

OTP MAP

The following table shows the one time programmable (OTP) regions of the register map. The OTP bits can be read only.

ADDRESS	Bit7	Bit6	Bit5	Bit4	Bit3	Bit2	Bit1	Bit0
0x0A	OTP BITS: ADDR[2:0]			COLD_RESET	SWITCH_MODE	DIS_VDD	DIS_VINOVLP	CC_FINE
0x0B	OTP BITS: ID[7:0]							

OTP DEFAULT

OTP ITEMS	DEFAULT
ICC	128mA
ITERM	3mA
VBAT_REG	4.2V
WATCHDOG	160s
EN_VINLOOP	Enable
Address	03H
Device ID	SGM41562A: 00000010. $V_{IN_OVLO} = 19V$
	SGM41562B: 00000000. $V_{IN_OVLO} = 6V$

STATE CONVERSION CHART

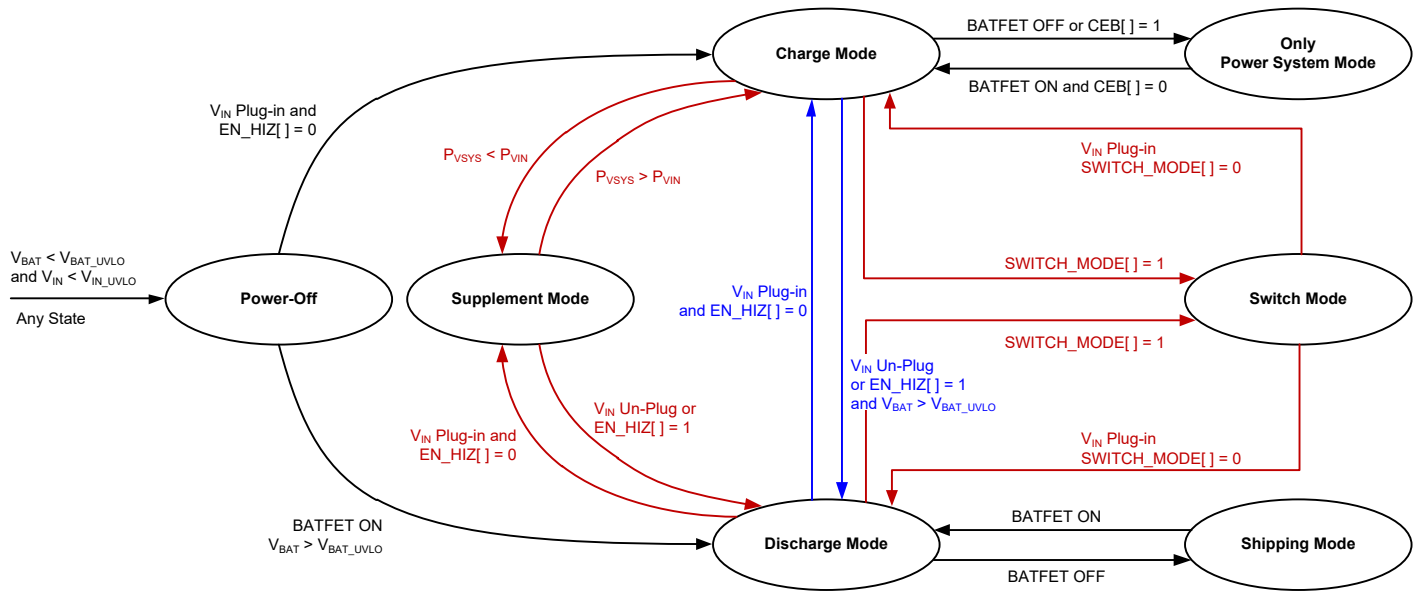

Figure 8. State Machine Conversion

CONTROL FLOW CHART

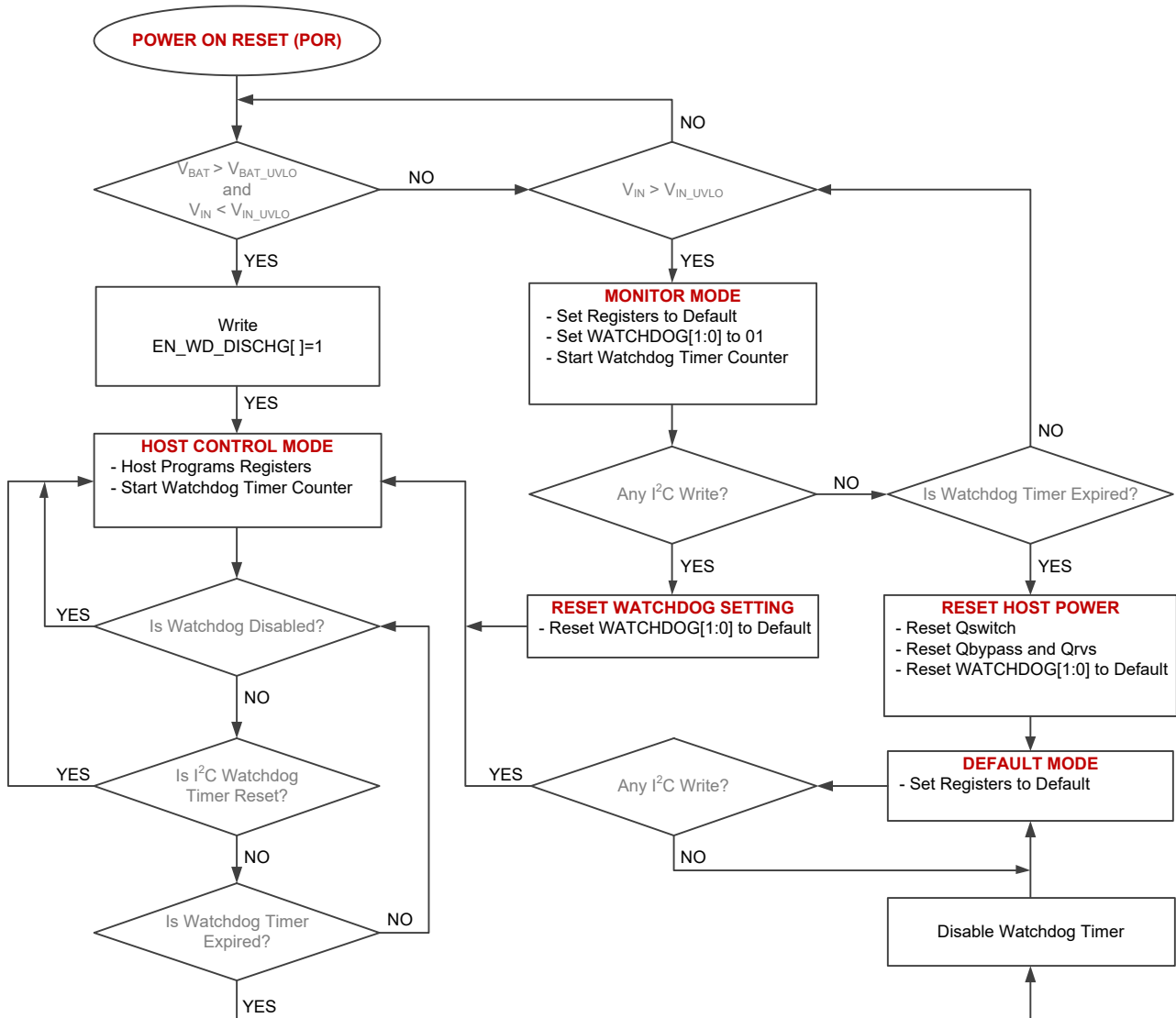

Figure 9. Startup, Host Mode, Default Mode and Host Power Reset

CONTROL FLOW CHART (continued)

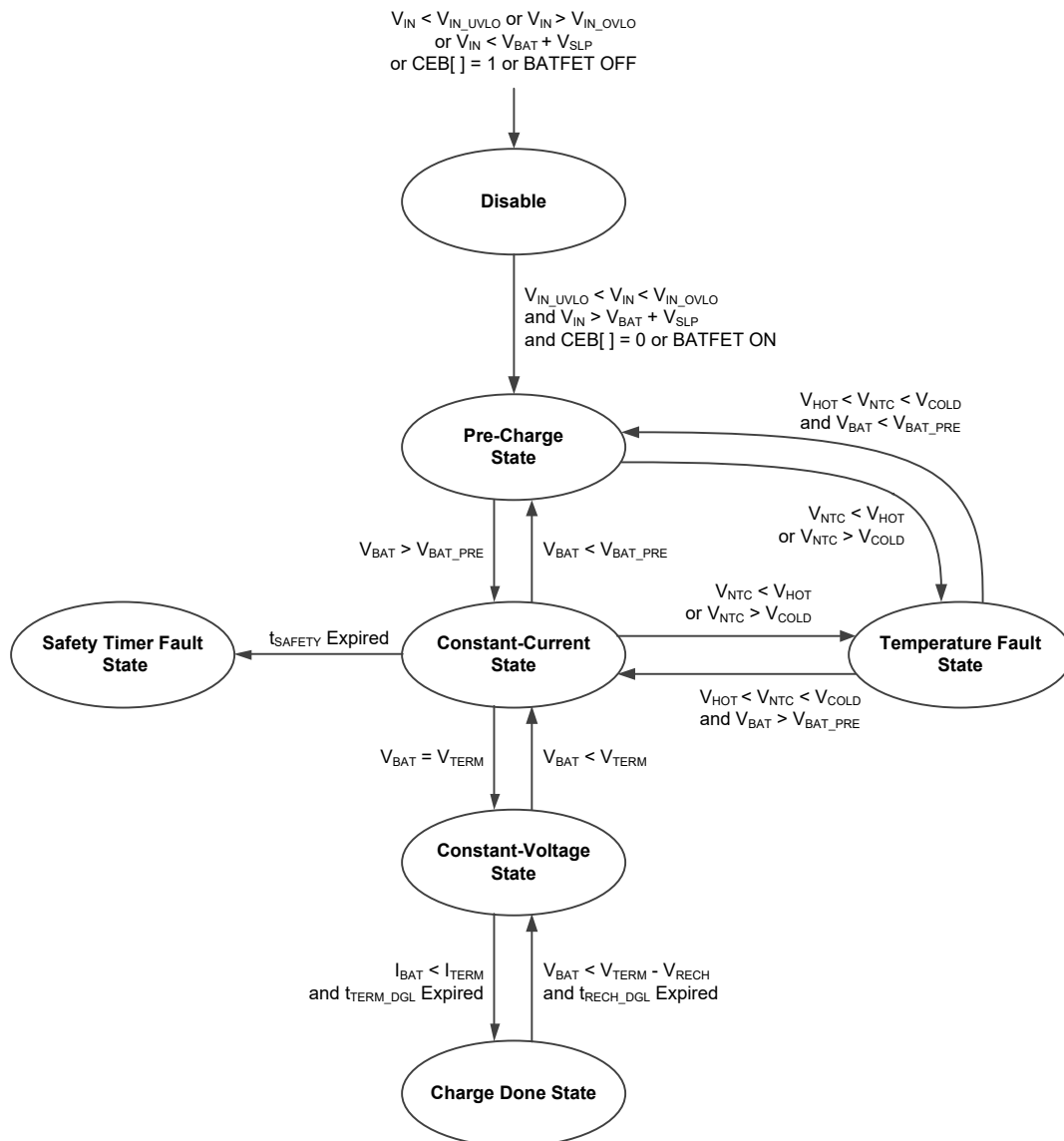

Figure 10. Charging Process

CONTROL FLOW CHART (continued)

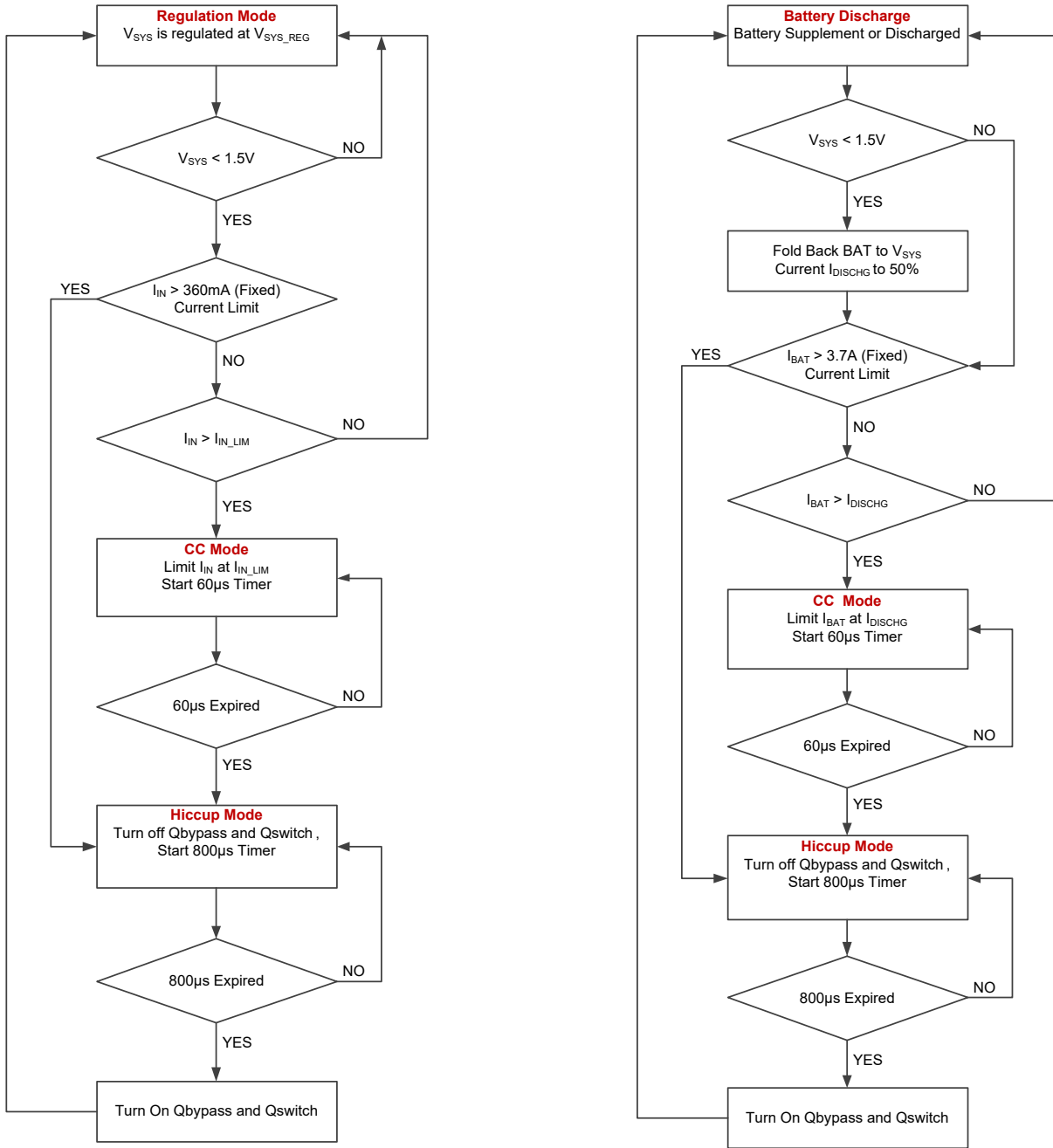

Figure 11. System Short Circuit Protection

APPLICATION INFORMATION

Resistor Divider for NTC Sensor

A resistor divider between VDD and GND pins can be used to adjust the battery temperature limits sensed by the NTC sensor. The R_{T1} and R_{T2} resistors (see Figure 12) allow independent programming of the high and low temperature limits for any type of NTC temperature characteristics.

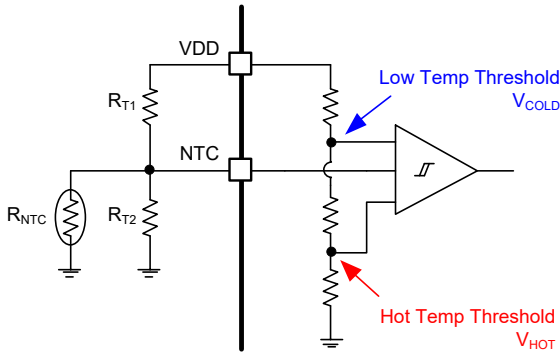

Figure 12. NTC Function Block

For a given NTC thermistor, if the NTC resistances at the desired high and low temperatures are R_{NTCH} and R_{NTCL} respectively, R_{T1} and R_{T2} values can be calculated by:

$$R_{T2} = \frac{(V_{COLD} - V_{HOT}) \times R_{NTCH} \times R_{NTCL}}{(V_{HOT} - V_{COLD} \times V_{HOT}) \times R_{NTCL} - (V_{COLD} - V_{COLD} \times V_{HOT}) \times R_{NTCH}}$$

$$R_{T1} = \frac{1 - V_{COLD}}{V_{COLD}} \times (R_{T2} / R_{NTCL})$$

where V_{COLD} and V_{HOT} thresholds values are voltage levels on the NTC pin given in the EC table for hot and cold detection.

For example, for a thermistor with R_{25°C} = 10kΩ and β = 3260, R_{NTCL} is 27.2kΩ at T_{COLD} = 0°C, and R_{NTCH} is 4.29kΩ at T_{HOT} = 50°C. Using Equation 1 and Equation 2 to calculate R_{T1} = 7.6kΩ and R_{T2} = 29.33kΩ (to be recalculated when the EC table mean values are characterized), assuming that the NTC window is between 0°C and 50°C and using the V_{COLD} and V_{HOT} values from the EC table.

External Capacitor Selection

Like many low-dropout regulators, SGM41562A/B requires external capacitors on its power ports for stability and noise or spike voltage immunity. These capacitors must be properly selected and placed near the device.

Input Capacitor (IN to GND)

A minimum 2.2μF input capacitor must be connected between IN and GND pins for stable operation over full load range. In general an output capacitance larger than the input capacitor is acceptable if the input capacitor is at least 2.2μF.

Output Capacitor (SYS to GND)

SGM41562B is designed specifically to operate with small ceramic output capacitance. A ceramic capacitor (X5R or X7R) larger than 2.2μF is suitable for the SGM41562A/B applications. The output capacitor should be connected close to the device between SYS and GND pins with thick traces and small loop area.

BAT to GND Capacitor

A capacitor is needed between BAT and GND pins. Use a ceramic capacitor (X5R or X7R) that is at least 2.2μF.

VDD to GND Capacitor

VDD voltage powers the internal control and logic circuit. It is critical to use a 0.1μF decoupling ceramic capacitor between VDD pin and GND close to the device with thick PCB traces to decouple noise and stabilize VDD voltage.

PCB Layout Guide

1. Place external capacitors as close as possible to the device to minimize stray inductances and connection impedance.
2. The GND for the I²C signals should be clean and directly connected to GND pin, without sharing its route with GND returns that carry high current or switching currents.
3. Due to relatively slow rise/fall times, it is ok to route the I²C wires in parallel on the same PCB layer.

TYPICAL APPLICATION CIRCUIT

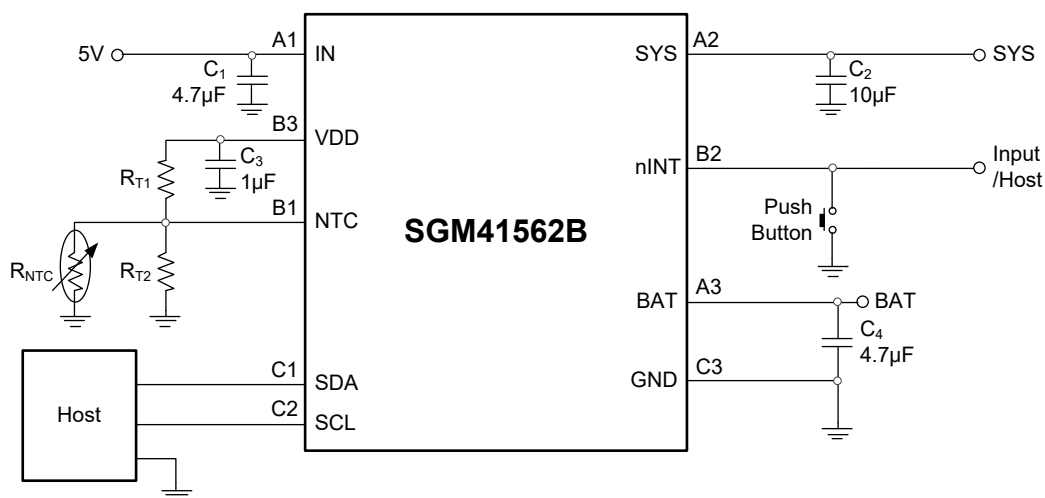

Figure 13. SGM41562B Typical Application Circuit with 5V Input

Table 16. The Key BOM of Figure 13

QTY	REF	VALUE	DESCRIPTION	PACKAGE
1	C1, C4	4.7µF	Ceramic Capacitor; 16V; X5R or X7R	0603
2	C2	10µF	Ceramic Capacitor; 16V; X5R or X7R	0603
1	C3	1µF	Ceramic Capacitor; 16V; X5R or X7R	0603

REVISION HISTORY

NOTE: Page numbers for previous revisions may differ from page numbers in the current version.

Changes from Original (DECEMBER 2021) to REV.A	Page
Changed from product preview to production data.....	All

PACKAGE OUTLINE DIMENSIONS

WLCSP-1.52x1.52-9B

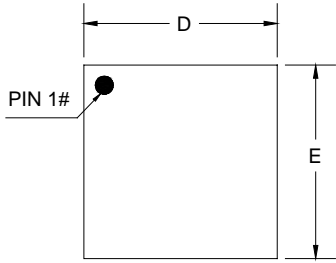

TOP VIEW

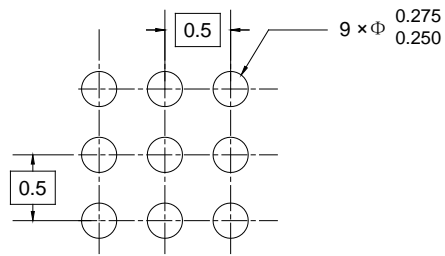

RECOMMENDED LAND PATTERN (Unit: mm)

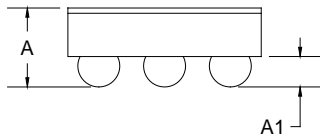

SIDE VIEW

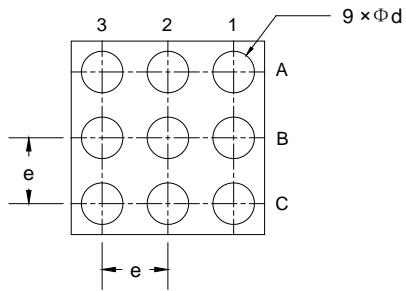

BOTTOM VIEW

Symbol	Dimensions In Millimeters		
	MIN	MOD	MAX
A	0.562	0.600	0.638
A1	0.211	0.231	0.251
D	1.500	1.525	1.550
E	1.500	1.525	1.550
d	0.296	0.316	0.336
e	0.500 BSC		

NOTE: This drawing is subject to change without notice.

PACKAGE INFORMATION

TAPE AND REEL INFORMATION

REEL DIMENSIONS

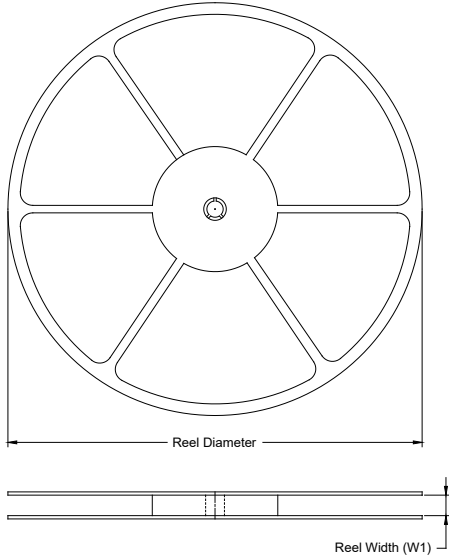

TAPE DIMENSIONS

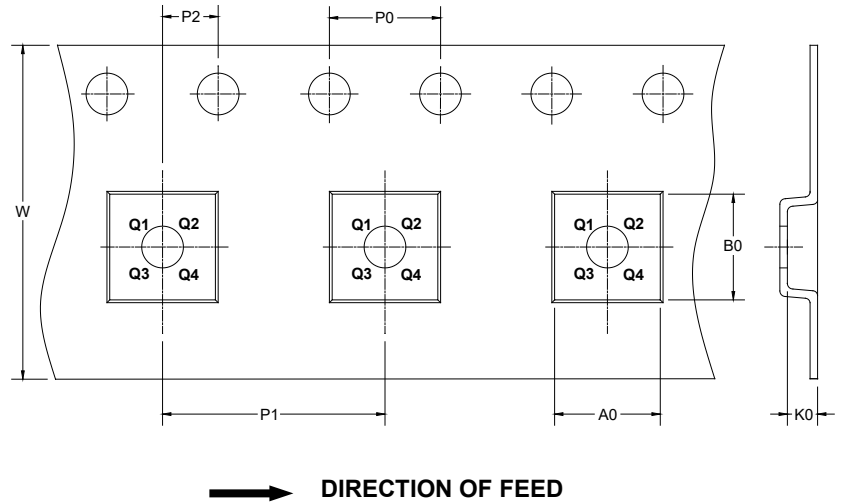

NOTE: The picture is only for reference. Please make the object as the standard.

KEY PARAMETER LIST OF TAPE AND REEL

Package Type	Reel Diameter	Reel Width W1 (mm)	A0 (mm)	B0 (mm)	K0 (mm)	P0 (mm)	P1 (mm)	P2 (mm)	W (mm)	Pin1 Quadrant
WLCSP-1.52×1.52-9B	7"	9.5	1.66	1.66	0.8	4.0	4.0	2.0	8.0	Q1

000001

PACKAGE INFORMATION

CARTON BOX DIMENSIONS

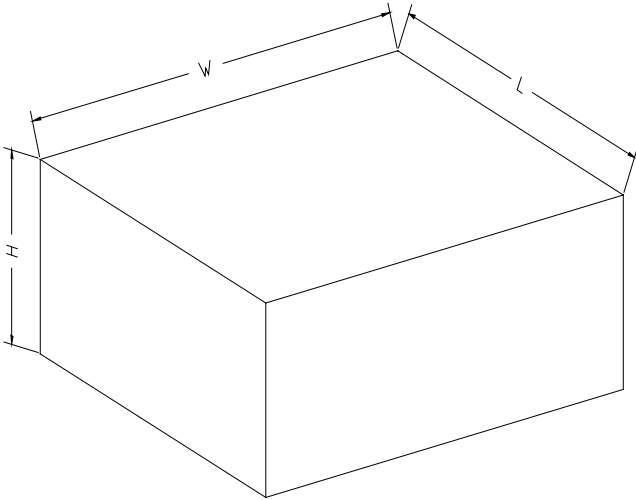

NOTE: The picture is only for reference. Please make the object as the standard.

KEY PARAMETER LIST OF CARTON BOX

Reel Type	Length (mm)	Width (mm)	Height (mm)	Pizza/Carton
7" (Option)	368	227	224	8
7"	442	410	224	18

DD0002