

Dual SPST Depletion Audio Switch with Negative Swing

FSA553

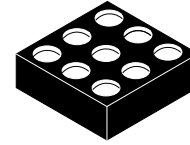

WLCSP9 1.385x1.215x0.581
CASE 567SV

Description

The FSA553 is a high-performance dual single-pole single-throw (SPST x 2) audio switch. The Depletion technology allows the device to conduct signals when there is no VCC available and to isolate signals when VCC is present. During signal conduction, the Depletion gate control allows the FSA553 to achieve excellent THD+N performance while consuming minimal power.

Features

- Dual SPST Depletion Switch
- Normally Closed when VCC < 0.2 V
- Switches Configurable through Select Pins
- V_{SW}: -1.5 V to +1.5 V
- R_{ON}: 0.4 Ω (Typical)
- R_{FLAT} < 0.01 Ω (Typical)
- THD+N: -104 dB (Typical)
- OIRR: -78 dB (Typical)
- This Device is Pb-Free and Halide Free

Table of Contents

- FSA553 Evaluation Board

Applications

- Smart Phones
- Tablets, Ultra Books

Block Diagram

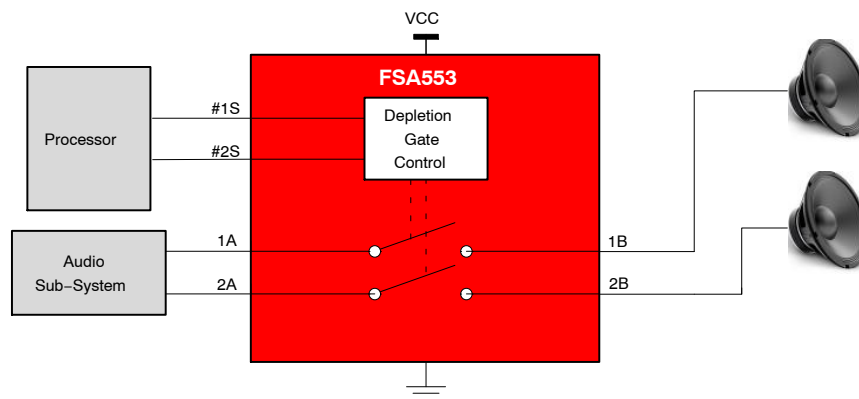

Figure 1. Application Block Diagram

MARKING DIAGRAM



NG = Specific Device Code
&K = 2-Digits Lot Run Traceability Code
&. = Pin One Dot
&2 = 2-Digit Date Code
&Z = Assembly Plant Code

*Date Code orientation and/or position may vary depending upon manufacturing location.

ORDERING INFORMATION

Device	Package	Shipping [†]
FSA553UCX	WLCSP9 (Pb-Free)	3000 / Tape & Reel

[†]For information on tape and reel specifications, including part orientation and tape sizes, please refer to our Tape and Reel Packaging Specifications Brochure, [BRD8011/D](#).

FSA553

Pin Configuration

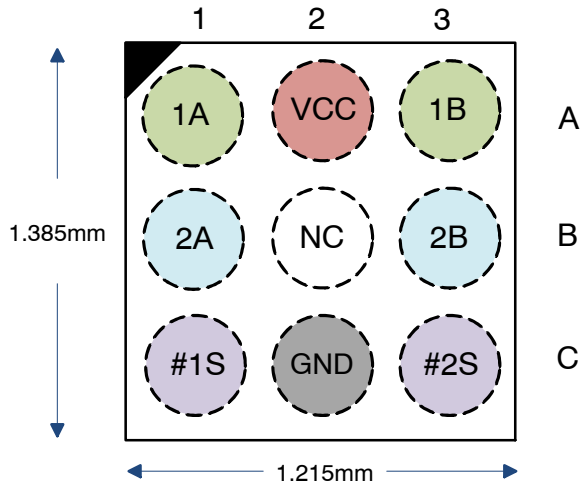

Figure 2. Top Through View

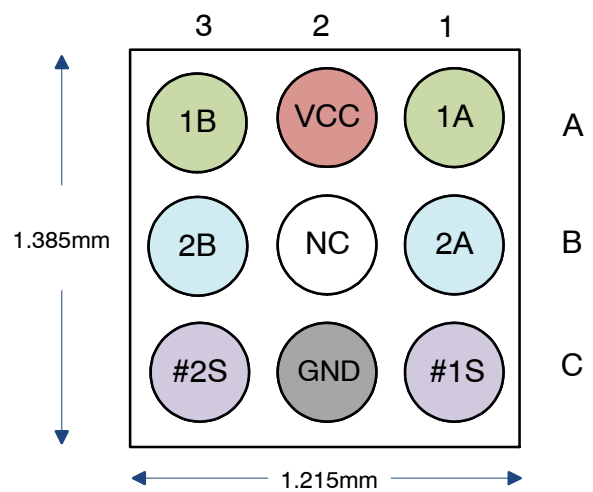

Figure 3. Bottom View

PIN DESCRIPTION

Pin #	Name	Type	Description
A1	1A	Depletion I/O	A–Port of Switch 1 (Normally Closed)
A3	1B	Depletion I/O	B–Port of Switch 1 (Normally Closed)
C1	#1S	Control	Select to Enable/Disable SW1 (Enable LOW)
A2	V _{CC}	Power Supply / Control	Power Supply Input
B2	NC	No Connect	Do Not Connect
C2	GND	Ground	Ground
B1	2A	Depletion I/O	A–Port of Switch 2 (Normally Closed)
B3	2B	Depletion I/O	B–Port of Switch 2 (Normally Closed)
C3	#2S	Control	Select to Enable/Disable SW2 (Enable LOW)

SWITCH TRUTH TABLE

V _{CC}	#1S	#2S	Switch 1	Switch 2
LOW	X	X	ON	ON
HIGH	HIGH	HIGH	OFF	OFF
HIGH	LOW	HIGH	ON	OFF
HIGH	HIGH	LOW	OFF	ON

FSA553

ABSOLUTE MAXIMUM RATINGS

Symbol	Parameter		Min	Max	Unit
V _{CC}	Supply/Control Voltage		-0.5	4.3	V
V _{CNTRL}	Select Input Voltage	#1S, #2S	-0.5	4.3	V
V _{SW(ON)}	DC Switch C Voltage (Switch Conducting)	1A, 1B, 2A, 2B	-2.0	2.0	V
V _{SW(OFF)}	DC Switch I/O Voltage (Switch Isolated)	1A, 1B, 2A, 2B	-2.0	2.0	V
I _{SW}	Switch I/O Current	V _{CC} = 0 V (Switch Conducting)		350	mA
I _{SWPEAK}	Peak Switch Current	Pulsed at 1 ms Duration, < 10% Duty Cycle		500	mA
ESD	Human Body Model, ANSI/ESDA/JEDEC JS-001-2012	I/O Ports		7	kV
		All Other Pins		4	
	Charged Device Model, JEDEC: JESD22-C101			2	
	IEC 61000-4-2 System	Contact		8	
		Air Gap		15	
T _A	Absolute Maximum Operating Temperature		-40	+85	°C
θ _{JA}	Thermal Resistance, Junction-to-Ambient	2S2P JEDEC std. PCB		97	°C/W
T _{STG}	Storage Temperature		-65	+150	°C

Stresses exceeding those listed in the Maximum Ratings table may damage the device. If any of these limits are exceeded, device functionality should not be assumed, damage may occur and reliability may be affected.

RECOMMENDED OPERATING CONDITIONS

Symbol	Parameter		Min	Max	Unit
V _{CC(ON)}	Supply Voltage with Depletion Switch Conducting (1A = 1B; 2A = 2B)		0	0.2	V
V _{CC(OFF)}	Supply Voltage with Depletion Switch Isolated (1A ≠ 1B; 2A ≠ 2B; #1S = #2S = HIGH)		1.5	3.0	V
V _{SW(ON)}	DC Switch I/O Input Voltage	Switch Conducting	-1.5	1.5	V
V _{SW(OFF)}	DC Switch I/O Input Voltage	Switch Isolated	-1.5	1.5	V
V _{CNTRL}	Select Input Voltage	#1S, #2S	0	3.0	V

Functional operation above the stresses listed in the Recommended Operating Ranges is not implied. Extended exposure to stresses beyond the Recommended Operating Ranges limits may affect device reliability.

FSA553

DC ELECTRICAL CHARACTERISTICS (Typical values are for $T_A = 25^\circ\text{C}$ unless otherwise specified.)

Symbol	Parameter	Condition	V _{CC} (V)	T _A = -40°C to +85°C			Unit
				Min	Typ	Max	
V _{CC(HYS)}	Supply Voltage Hysteresis				450		mV
I _{ON}	Switch ON Leakage Current	nA = -0.5 V, 0.5 V, 1.5 V, -1.5 V, nB = Float, #1S = #2S = Float	0		0.1		μA
I _{OFF}	Switch OFF Leakage Current	nA = -0.5 V, 0.5 V, 1.5 V, -1.5 V, nB = GND, #1S = #2S = V _{CC}	1.8		0.5		μA
I _{CCT}	Increase in I _{CC} for each Select Pin	#1S = V _{CC} , #2S = 1.2 V, #1S = 1.2 V, #2S = V _{CC}	3.0		7		μA
R _{ON}	Switch On Resistance	I _{SW} = 100 mA, V _{SW} = -1.5 V to +1.5 V	0		0.40	0.80	Ω
ΔR _{ON}	Switch On Resistance Difference, Channel to Channel	I _{SW} = 100 mA, V _{SW} = -1.5 V to +1.5 V	0		0.01		Ω
R _{FLAT(ON)}	On Resistance Flatness	I _{SW} = 100 mA, V _{SW} = -1.5 V to +1.5 V	0		0.01		Ω
R _{PD}	V _{CC} Pull-Down Resistance		<0.2		5.0		MΩ
R _{PU}	Select Pull-Up Resistance		<0.2		3.0		MΩ
I _{CC}	Quiescent Supply Current	Switch Isolated, #1S = #2S = V _{CC}	1.5 to 3.0		80		μA
		Switch On	0.2		0.5		
V _{IH}	Select Pin Input High Voltage		1.5 to 3.0	1.2			V
V _{IL}	Select Pin Input Low Voltage		1.5 to 3.0			0.55	V

Product parametric performance is indicated in the Electrical Characteristics for the listed test conditions, unless otherwise noted. Product performance may not be indicated by the Electrical Characteristics if operated under different conditions.

FSA553

AC ELECTRICAL CHARACTERISTICS (Typical values are for $T_A = 25^\circ\text{C}$ unless otherwise specified.)

Symbol	Parameter	Condition	V_{CC} (V)	$T_A = -40^\circ\text{C to }+85^\circ\text{C}$			Unit	
				Min	Typ	Max		
t_{ON}	Turn-On Time V_{CC} to Output	$R_L = 32 \Omega$, $C_L = 10 \text{ pF}$, #nS = Float, Figure 4	$W_{SW} = 1.5 \text{ V}$	1.8→0		450	μs	
			$W_{SW} = -1.5 \text{ V}$	1.8→0		350		
t_{OFF}	Turn-Off Time V_{CC} to Output	$R_L = 32 \Omega$, $C_L = 10 \text{ pF}$, #nS = Float, Figure 4	$W_{SW} = 1.5 \text{ V}$	0→1.8		250	μs	
			$W_{SW} = -1.5 \text{ V}$	0→1.8		150		
t_{ONS}	Turn-On Time Select Pin	$R_L = 32 \Omega$, $C_L = 10 \text{ pF}$, #nS = $V_{CC} \rightarrow 0$, Figure 5	$W_{SW} = 1.5 \text{ V}$	1.8		350	μs	
			$W_{SW} = -1.5 \text{ V}$	1.8		300		
t_{OFFS}	Turn-Off Time Select Pin	$R_L = 32 \Omega$, $C_L = 10 \text{ pF}$, #nS = $0 \rightarrow V_{CC}$, Figure 5	$W_{SW} = 1.5 \text{ V}$	1.8		150	μs	
			$W_{SW} = -1.5 \text{ V}$	1.8		50		
BW	-3 dB Bandwidth	$V_{SW} = 600 \text{ mV}_{p-p}$, $R_L = 50 \Omega$; $C_L = 5 \text{ pF}$,	0		200		MHz	
THD+N	Total Harmonic Distortion + Noise	$V_{SW} = 1 \text{ V}_{RMS}$, $R_L = 32 \Omega$, $f = 1 \text{ kHz}$	0			-104	dB	
						A-weighted		-107
O_{IRR}	Port Off Isolation	$V_{SW} = 0.707 \text{ V}_{RMS}$, $R_L = 32 \Omega$, $f = 20 \text{ Hz to } 100 \text{ kHz}$, Figure 6	1.8		-70	-82	dB	
X_{TALK}	Cross Talk	$V_{SW} = 1 \text{ V}_{RMS}$, $f = 100 \text{ kHz}$, $R_L = 32 \Omega$	1.8			-75	dB	
		$V_{SW} = 1 \text{ V}_{RMS}$, $f = 20 \text{ kHz}$, $R_L = 32 \Omega$				-100		
PSRR	Power Supply Rejection Ratio	Switch Isolating, $V_{Ripple} = V_{CC} + 300 \text{ mV}_{p-p}$, $R_L = 32 \Omega$	1.8			-80	dB	
						217 Hz		-77
						1 kHz		-73
		20 kHz						

CAPACITANCE (Typical values are for $T_A = 25^\circ\text{C}$ unless otherwise specified.)

Symbol	Parameter	Condition	V_{CC} (V)	$T_A = -40^\circ\text{C to }+85^\circ\text{C}$			Unit
				Min	Typ	Max	
C_{ON}	On Capacitance	$V_{SW} = 400 \text{ mV}_{PP}$, $f = 1 \text{ MHz}$,	0		21		pF
C_{OFF}	Off Capacitance	$V_{SW} = 400 \text{ mV}_{PP}$, $f = 1 \text{ MHz}$, #1S = #2S = V_{CC}	1.8		25		pF
C_{CTRL}	Select Pin Capacitance	#nS = 400 mV_{PP} , $f = 1 \text{ MHz}$	1.8		5		pF

FSA553

TIMING DIAGRAMS

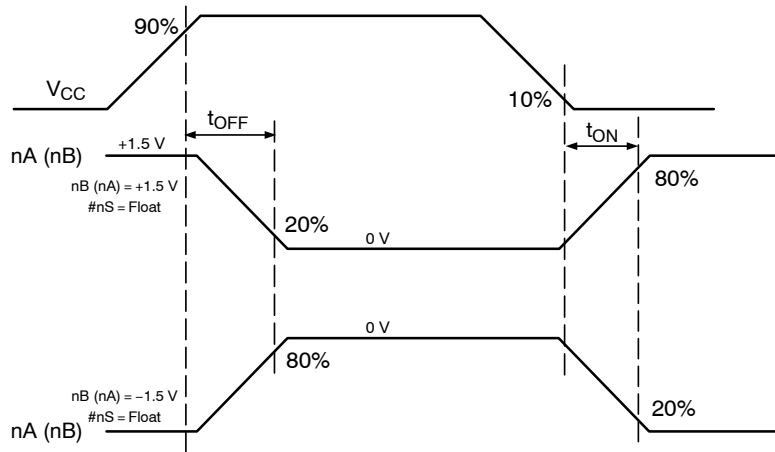

Figure 4. t_{ON}/t_{OFF} V_{CC} to Output Timing

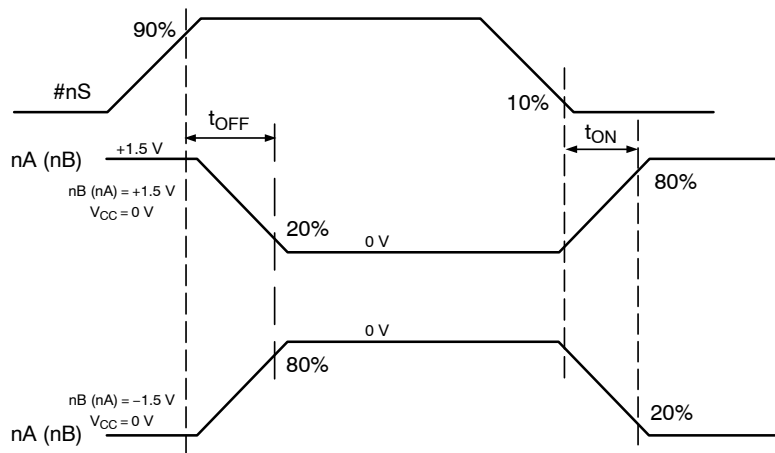

Figure 5. t_{ON}/t_{OFF} Select (#nS) to Output Timing

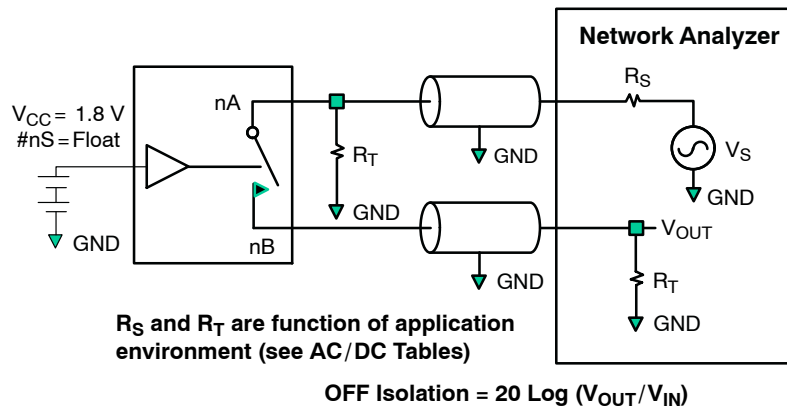

Figure 6. OFF Isolation

PRODUCT-SPECIFIC DIMENSIONS

E	D	X	Y
1.215±0.03 mm	1.385±0.03 mm	0.2075	0.2925

MECHANICAL CASE OUTLINE

PACKAGE DIMENSIONS

WLCSP9 1.385x1.215x0.581
CASE 567SV
ISSUE O

DATE 30 NOV 2016

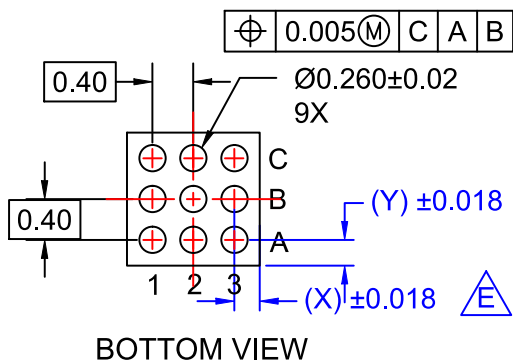
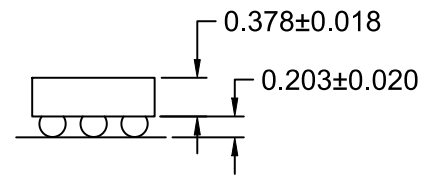
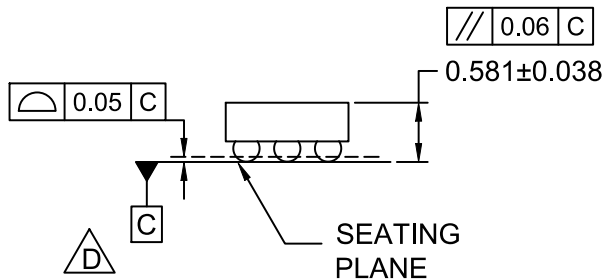
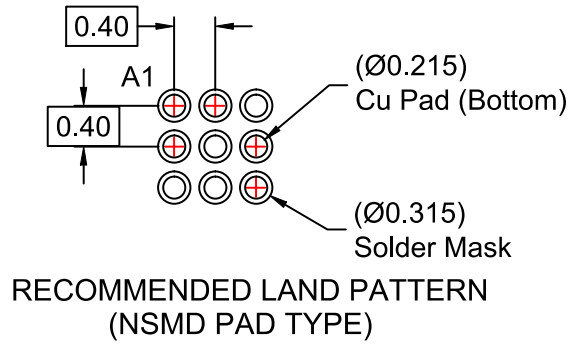
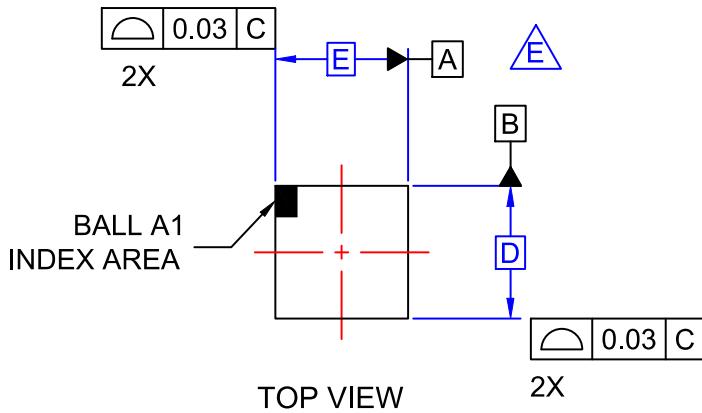

NOTES

- A. NO JEDEC REGISTRATION APPLIES.
- B. DIMENSIONS ARE IN MILLIMETERS.
- C. DIMENSIONS AND TOLERANCE PER ASME Y14.5M, 2009.
- D. DATUM C IS DEFINED BY THE SPHERICAL CROWNS OF THE BALLS.
- E. FOR DIMENSIONS D, E, X, AND Y SEE PRODUCT DATASHEET.