

TPS22998 5.5-V, 10-A, 4-mΩ On-Resistance Load Switch

1 Features

- Input operating voltage range (V_{IN}): 0.2 V–5.5 V
- Bias voltage range: 2.2 V–5.5 V
- Maximum continuous current: 10 A
- ON-Resistance (R_{ON}): 4 mΩ (typ.)
- Adjustable slew rate with tri-state pin
- Quick Output Discharge (QOD): 50 Ω
- Thermal shutdown
- Low power consumption:
 - ON state (I_Q): 15 μA (typ.)
 - OFF state (I_{SD}): 3 μA (typ.)

2 Applications

- [Solid state drive](#)
- [PC and notebooks](#)
- [Industrial PC](#)
- [Optical module](#)

3 Description

The TPS22998 is a single-channel load switch that provides a configurable rise time to minimize inrush current. The device contains an N-channel MOSFET that can operate over an input voltage range of 0.2 V to 5.5 V and can support a maximum continuous current of 10 A.

The switch is controlled by an on and off input (ON), which is capable of interfacing directly with low voltage control signals ($V_{IH} = 0.9$ V). The TPS22998 has a fixed quick output discharge when switch is turned off, pulling the output down to ground.

The TPS22998 is available in a 1.5 × 2.0 mm, 0.5 mm pitch, 10-pin WQFN package (RYZ) and is characterized for operation over the free-air temperature range of –40°C to +105°C.

Device Information

| PART NUMBER | PACKAGE ⁽¹⁾ | BODY SIZE (NOM) |
|-------------|------------------------|-----------------|
| TPS22998 | WQFN (10) | 1.5 × 2.0 mm |

- (1) For all available packages, see the orderable addendum at the end of the data sheet.

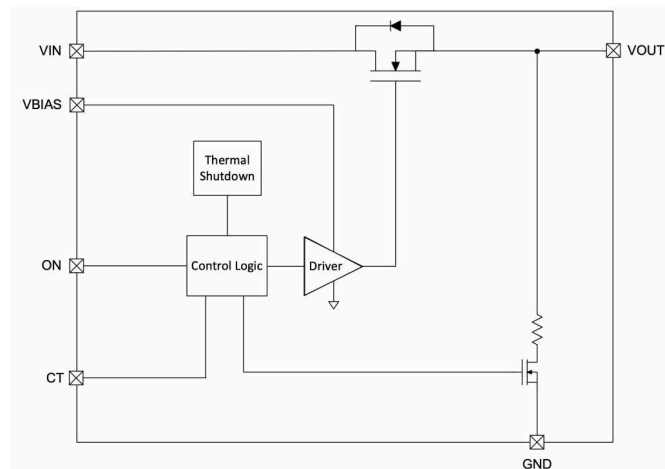

TPS22998 Block Diagram

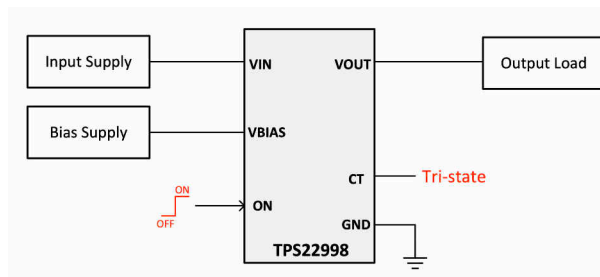

TPS22998 Typical Application

Table of Contents

| | | | |
|---|----|--|----|
| 1 Features | 1 | 7.2 Functional Block Diagram..... | 11 |
| 2 Applications | 1 | 7.3 Feature Description..... | 11 |
| 3 Description | 1 | 7.4 Device Functional Modes..... | 12 |
| 4 Revision History | 2 | 8 Application and Implementation | 13 |
| 5 Pin Configuration and Functions | 3 | 8.1 Application Information..... | 13 |
| 6 Specifications | 4 | 8.2 Typical Application..... | 13 |
| 6.1 Absolute Maximum Ratings..... | 4 | 9 Power Supply Recommendations | 15 |
| 6.2 ESD Ratings..... | 4 | 10 Layout | 15 |
| 6.3 Recommended Operating Conditions..... | 4 | 10.1 Layout Guidelines..... | 15 |
| 6.4 Thermal Information..... | 4 | 10.2 Layout Example..... | 15 |
| 6.5 Electrical Characteristics (VBIAS = 5 V)..... | 5 | 11 Device and Documentation Support | 16 |
| 6.6 Electrical Characteristics (VBIAS = 3.3 V)..... | 5 | 11.1 Receiving Notification of Documentation Updates.. | 16 |
| 6.7 Electrical Characteristics (VBIAS = 2.2 V)..... | 6 | 11.2 Support Resources..... | 16 |
| 6.8 Switching Characteristics (VBIAS = 2.2 V to 5 V)..... | 7 | 11.3 Trademarks..... | 16 |
| 6.9 Timing Diagram..... | 8 | 11.4 Electrostatic Discharge Caution..... | 16 |
| 6.10 Typical Characteristics..... | 9 | 11.5 Glossary..... | 16 |
| 7 Detailed Description | 11 | 12 Mechanical, Packaging, and Orderable Information | 17 |
| 7.1 Overview..... | 11 | | |

4 Revision History

NOTE: Page numbers for previous revisions may differ from page numbers in the current version.

| Changes from Revision * (October 2021) to Revision A (December 2021) | Page |
|--|------|
| • Changed data sheet status from "Advance Information" to "Production Data"..... | 1 |

5 Pin Configuration and Functions

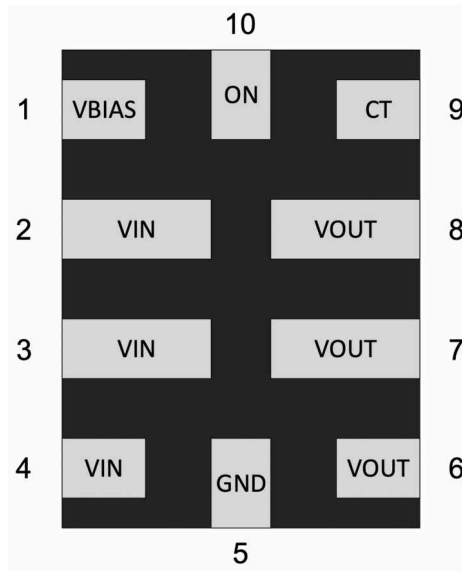

Figure 5-1. TPS22998 RYZ Package, 10-Pin WQFN (Top View)

Table 5-1. Pin Functions

| PIN | | I/O ⁽¹⁾ | DESCRIPTION |
|-------|---------|--------------------|---|
| NAME | NO. | | |
| VBIAS | 1 | I | Device bias supply |
| VIN | 2, 3, 4 | I | Switch input |
| GND | 5 | G | Device ground |
| VOUT | 6, 7, 8 | O | Switch output |
| CT | 9 | I | Slew rate control – can be pulled up, left floating, or tie to ground |
| ON | 10 | I | Enable pin |

(1) I = Input, O = Output, I/O = Input or Output, G = Ground, P = Power.

6 Specifications

6.1 Absolute Maximum Ratings

over operating free-air temperature range (unless otherwise noted)⁽¹⁾

| | | MIN | MAX | UNIT |
|-----------------------------------|----------------------|------|--------------------|------|
| V _{IN} | Input Voltage | -0.3 | 6 | V |
| V _{BIAS} | Bias Voltage | -0.3 | 6 | V |
| V _{ON} , V _{CT} | Control Pin Voltage | -0.3 | 6 | V |
| I _{MAX} | Maximum Current | | 10 | A |
| T _J | Junction temperature | | Internally Limited | °C |
| T _{stg} | Storage temperature | -65 | 150 | °C |

- (1) Operation outside the Absolute Maximum Ratings may cause permanent device damage. Absolute Maximum Ratings do not imply functional operation of the device at these or any other conditions beyond those listed under Recommended Operating Conditions. If used outside the Recommended Operating Conditions but within the Absolute Maximum Ratings, the device may not be fully functional, and this may affect device reliability, functionality, performance, and shorten the device lifetime.

6.2 ESD Ratings

| | | | VALUE | UNIT |
|--------------------|-------------------------|--|-------|------|
| V _(ESD) | Electrostatic discharge | Human body model (HBM), per ANSI/ESDA/ JEDEC JS-001 ⁽¹⁾ | ±2000 | V |
| | | Charged device model (CDM), per ANSI/ESDA/ JEDEC JS-002 ⁽²⁾ | ±1000 | |

- (1) JEDEC document JEP155 states that 500-V HBM allows safe manufacturing with a standard ESD control process.
 (2) JEDEC document JEP157 states that 250-V CDM allows safe manufacturing with a standard ESD control process.

6.3 Recommended Operating Conditions

over operating free-air temperature range (unless otherwise noted)

| | | MIN | NOM | MAX | UNIT |
|-------------------|---------------------|-----|-----|-----|------|
| V _{IN} | Input Voltage | 0.2 | | 5.5 | V |
| V _{BIAS} | Bias Voltage | 2.2 | | 5.5 | V |
| V _{CT} | Control Pin Voltage | 0 | | 5.5 | V |
| T _A | Ambient Temperature | -40 | | 105 | °C |

6.4 Thermal Information

| THERMAL METRIC ⁽¹⁾ | | TPS22998 | UNIT |
|-------------------------------|--|------------|------|
| | | RYZ (WQFN) | |
| | | 10 PINS | |
| R _{θJA} | Junction-to-ambient thermal resistance | 84.1 | °C/W |
| R _{θJC(top)} | Junction-to-case (top) thermal resistance | 77.5 | °C/W |
| R _{θJB} | Junction-to-board thermal resistance | 16.6 | °C/W |
| Ψ _{JT} | Junction-to-top characterization parameter | 4.0 | °C/W |
| Y _{JB} | Junction-to-board characterization parameter | 16.0 | °C/W |

- (1) For more information about traditional and new thermal metrics, see the [Semiconductor and IC Package Thermal Metrics](#) application report.

6.5 Electrical Characteristics (VBIAS = 5 V)

Over operating free-air temperature range (unless otherwise noted). Typical values are at $T_A = 25^\circ\text{C}$.

| PARAMETER | | TEST CONDITIONS | T_A | MIN | TYP | MAX | UNIT |
|--------------------------|-----------------------------|--------------------|----------------|-------|-----|-------|------|
| Power Consumption | | | | | | | |
| $I_{SD,VBIAS}$ | VBIAS Shutdown Current | ON = 0 V | 25°C | 3 | | | µA |
| | | | -40°C to 85°C | | | 5 | µA |
| | | | -40°C to 105°C | | | 6 | µA |
| $I_{Q,VBIAS}$ | VBIAS Quiescent Current | ON > V_{IH} | 25°C | 15 | | | µA |
| | | | -40°C to 85°C | | | 20 | µA |
| | | | -40°C to 105°C | | | 20 | µA |
| $I_{SD,VIN}$ | VIN Shutdown Current | ON = 0 V | 25°C | 0.1 | | | µA |
| | | | -40°C to 85°C | | | 1 | µA |
| | | | -40°C to 105°C | | | 2 | µA |
| I_{ON} | ON pin leakage | ON = VBIAS | -40°C to 105°C | 0.1 | | | µA |
| Performance | | | | | | | |
| R_{ON} | On-Resistance | VIN = 0.2 V to 5 V | 25°C | 4 | | | mΩ |
| | | | -40°C to 85°C | | | 6 | mΩ |
| | | | -40°C to 105°C | | | 7 | mΩ |
| V_{IH} | Turn on threshold, rising | | -40°C to 105°C | 0.765 | 0.9 | 1.035 | V |
| V_{IL} | Turn off threshold, falling | | -40°C to 105°C | 0.595 | 0.7 | 0.805 | V |
| $V_{ON,HYST}$ | ON pin hysteresis | | -40°C to 105°C | 0.2 | | | V |
| $t_{ON,DEGLITCH}$ | On pin deglitch time | | -40°C to 105°C | 2 | 5 | 7 | µs |
| R_{QOD} | QOD Resistance | VOUT = VIN | 25°C | 50 | | | Ω |
| | | | -40°C to 105°C | 40 | 60 | | Ω |
| Protection | | | | | | | |
| TSD | Thermal Shutdown | | - | 130 | 150 | 180 | °C |
| TSD _{HYS} | Thermal Shutdown Hysteresis | | - | 20 | | | °C |

6.6 Electrical Characteristics (VBIAS = 3.3 V)

Over operating free-air temperature range (unless otherwise noted). Typical values are at $T_A = 25^\circ\text{C}$.

| PARAMETER | | TEST CONDITIONS | T_A | MIN | TYP | MAX | UNIT |
|--------------------------|-------------------------|-----------------|----------------|-----|-----|-----|------|
| Power Consumption | | | | | | | |
| $I_{SD,VBIAS}$ | VBIAS Shutdown Current | ON = 0 V | 25°C | 3 | | | µA |
| | | | -40°C to 85°C | | | 5 | µA |
| | | | -40°C to 105°C | | | 5 | µA |
| $I_{Q,VBIAS}$ | VBIAS Quiescent Current | ON > V_{IH} | 25°C | 15 | | | µA |
| | | | -40°C to 85°C | | | 20 | µA |
| | | | -40°C to 105°C | | | 20 | µA |
| $I_{SD,VIN}$ | VIN Shutdown Current | ON = 0 V | 25°C | 0.1 | | | µA |
| | | | -40°C to 85°C | | | 1 | µA |
| | | | -40°C to 105°C | | | 3 | µA |
| I_{ON} | ON pin leakage | ON = VBIAS | -40°C to 105°C | 0.1 | | 1 | µA |
| Performance | | | | | | | |

6.6 Electrical Characteristics (VBIAS = 3.3 V) (continued)

Over operating free-air temperature range (unless otherwise noted). Typical values are at $T_A = 25^\circ\text{C}$.

| PARAMETER | | TEST CONDITIONS | T_A | MIN | TYP | MAX | UNIT |
|--------------------|------------------------------------|---|--|-------|-----|-------|------------------|
| R_{ON} | On-Resistance | $V_{IN} = 0.2\text{ V to }3.3\text{ V}$ | 25°C | 4 | | | $\text{m}\Omega$ |
| | | | $-40^\circ\text{C to }85^\circ\text{C}$ | 7 | | | $\text{m}\Omega$ |
| | | | $-40^\circ\text{C to }105^\circ\text{C}$ | 7 | | | $\text{m}\Omega$ |
| V_{IH} | ON pin turn on threshold, rising | | $-40^\circ\text{C to }105^\circ\text{C}$ | 0.765 | 0.9 | 1.035 | V |
| V_{IL} | ON pin turn off threshold, falling | | $-40^\circ\text{C to }105^\circ\text{C}$ | 0.595 | 0.7 | 0.805 | V |
| $V_{ON, HYST}$ | ON pin hysteresis | | $-40^\circ\text{C to }105^\circ\text{C}$ | 0.2 | | | V |
| $t_{ON, DEGLITCH}$ | On pin deglitch time | | $-40^\circ\text{C to }105^\circ\text{C}$ | 2 | 5 | 6.5 | μs |
| R_{QOD} | QOD Resistance | $V_{OUT} = V_{IN}$ | 25°C | 50 | | | Ω |
| | | | $-40^\circ\text{C to }105^\circ\text{C}$ | 40 | 60 | | Ω |
| Protection | | | | | | | |
| TSD | Thermal Shutdown | | - | 130 | 150 | 180 | $^\circ\text{C}$ |
| TSD_{HYS} | Thermal Shutdown Hysteresis | | - | 20 | | | $^\circ\text{C}$ |

6.7 Electrical Characteristics (VBIAS = 2.2 V)

Over operating free-air temperature range (unless otherwise noted). Typical values are at $T_A = 25^\circ\text{C}$.

| PARAMETER | | TEST CONDITIONS | T_A | MIN | TYP | MAX | UNIT |
|--------------------------|------------------------------------|---|--|-------|-----|-------|------------------|
| Power Consumption | | | | | | | |
| $I_{SD, VBIAS}$ | VBIAS Shutdown Current | $ON = 0\text{ V}$ | 25°C | 3 | | | μA |
| | | | $-40^\circ\text{C to }85^\circ\text{C}$ | 5 | | | μA |
| | | | $-40^\circ\text{C to }105^\circ\text{C}$ | 5 | | | μA |
| $I_{Q, VBIAS}$ | VBIAS Quiescent Current | $ON > V_{IH}$ | 25°C | 15 | | | μA |
| | | | $-40^\circ\text{C to }85^\circ\text{C}$ | 20 | | | μA |
| | | | $-40^\circ\text{C to }105^\circ\text{C}$ | 20 | | | μA |
| $I_{SD, VIN}$ | VIN Shutdown Current | $ON = 0\text{ V}$ | 25°C | 0.1 | | | μA |
| | | | $-40^\circ\text{C to }85^\circ\text{C}$ | 1 | | | μA |
| | | | $-40^\circ\text{C to }105^\circ\text{C}$ | 3 | | | μA |
| I_{ON} | ON pin leakage | $ON = V_{BIAS}$ | $-40^\circ\text{C to }105^\circ\text{C}$ | 0.1 | 1 | | μA |
| Performance | | | | | | | |
| R_{ON} | On-Resistance | $V_{IN} = 0.2\text{ V to }2.2\text{ V}$ | 25°C | 4.3 | | | $\text{m}\Omega$ |
| | | | $-40^\circ\text{C to }85^\circ\text{C}$ | 7 | | | $\text{m}\Omega$ |
| | | | $-40^\circ\text{C to }105^\circ\text{C}$ | 7 | | | $\text{m}\Omega$ |
| V_{IH} | ON pin turn on threshold, rising | | $-40^\circ\text{C to }105^\circ\text{C}$ | 0.765 | 0.9 | 1.035 | V |
| V_{IL} | ON pin turn off threshold, falling | | $-40^\circ\text{C to }105^\circ\text{C}$ | 0.595 | 0.7 | 0.805 | V |
| $V_{ON, HYST}$ | ON pin hysteresis | | $-40^\circ\text{C to }105^\circ\text{C}$ | 0.2 | | | V |
| $t_{ON, DEGLITCH}$ | On pin deglitch time | | $-40^\circ\text{C to }105^\circ\text{C}$ | 2 | 4.5 | 6.5 | μs |
| R_{QOD} | QOD Resistance | $V_{OUT} = V_{IN}$ | 25°C | 50 | | | Ω |
| | | | $-40^\circ\text{C to }105^\circ\text{C}$ | 40 | 60 | | Ω |
| Protection | | | | | | | |
| TSD | Thermal Shutdown | | - | 130 | 150 | 180 | $^\circ\text{C}$ |
| TSD_{HYS} | Thermal Shutdown Hysteresis | | - | 20 | | | $^\circ\text{C}$ |

6.8 Switching Characteristics (VBIAS = 2.2 V to 5 V)

Over operating free-air temperature range (unless otherwise noted), C_{IN}=47uF. Typical values are at T_A = 25°C, C_L = 0.1μF, and a current load of 1mA.

| PARAMETER | | TEST CONDITIONS | MIN | TYP | MAX | UNIT |
|--------------------|---------------|------------------------|-----|------|-----|------|
| VIN = 5 V | | | | | | |
| t _{ON} | Turn ON time | CT = Open | | 250 | | us |
| t _{ON} | Turn ON time | CT = V _{BIAS} | | 1870 | | us |
| t _{ON} | Turn ON time | CT = GND | | 3728 | | us |
| t _{RISE} | Rise time | CT = Open | | 225 | | us |
| t _{RISE} | Rise time | CT = V _{BIAS} | | 1838 | | us |
| t _{RISE} | Rise time | CT = GND | | 3697 | | us |
| t _D | Delay time | CT = Open | | 26 | | us |
| t _D | Delay time | CT = V _{BIAS} | | 31 | | us |
| t _D | Delay time | CT = GND | | 31 | | us |
| t _{FALL} | Fall time | CT = Open | | 11 | | us |
| t _{OFF} | Turn OFF time | CT = Open | | 3 | | us |
| VIN = 3.3 V | | | | | | |
| t _{ON} | Turn ON time | CT = Open | | 175 | | us |
| t _{ON} | Turn ON time | CT = V _{BIAS} | | 1261 | | us |
| t _{ON} | Turn ON time | CT = GND | | 3586 | | us |
| t _{RISE} | Rise time | CT = Open | | 150 | | us |
| t _{RISE} | Rise time | CT = V _{BIAS} | | 1232 | | us |
| t _{RISE} | Rise time | CT = GND | | 2478 | | us |
| t _D | Delay time | CT = Open | | 26 | | us |
| t _D | Delay time | CT = V _{BIAS} | | 29 | | us |
| t _D | Delay time | CT = GND | | 29 | | us |
| t _{FALL} | Fall time | CT = Open | | 11 | | us |
| t _{OFF} | Turn OFF time | CT = Open | | 3 | | us |
| VIN = 1.8 V | | | | | | |
| t _{ON} | Turn ON time | CT = Open | | 102 | | us |
| t _{ON} | Turn ON time | CT = V _{BIAS} | | 664 | | us |
| t _{ON} | Turn ON time | CT = GND | | 1302 | | us |
| t _{RISE} | Rise time | CT = Open | | 75 | | us |
| t _{RISE} | Rise time | CT = V _{BIAS} | | 634 | | us |
| t _{RISE} | Rise time | CT = GND | | 1272 | | us |
| t _D | Delay time | CT = Open | | 27 | | us |
| t _D | Delay time | CT = V _{BIAS} | | 29 | | us |
| t _D | Delay time | CT = GND | | 30 | | us |
| t _{FALL} | Fall time | CT = Open | | 11 | | us |
| t _{OFF} | Turn OFF time | CT = Open | | 3 | | us |
| VIN = 0.6 V | | | | | | |
| t _{ON} | Turn ON time | CT = Open | | 51 | | us |
| t _{ON} | Turn ON time | CT = V _{BIAS} | | 213 | | us |
| t _{ON} | Turn ON time | CT = GND | | 393 | | us |
| t _{RISE} | Rise time | CT = Open | | 23 | | us |
| t _{RISE} | Rise time | CT = V _{BIAS} | | 183 | | us |
| t _{RISE} | Rise time | CT = GND | | 365 | | us |

6.8 Switching Characteristics (VBIAS = 2.2 V to 5 V) (continued)

Over operating free-air temperature range (unless otherwise noted), CIN=47uF. Typical values are at TA = 25°C, CL = 0.1µF, and a current load of 1mA.

| PARAMETER | | TEST CONDITIONS | MIN | TYP | MAX | UNIT |
|----------------------|---------------|-----------------|-----|-----|-----|------|
| tD | Delay time | CT = Open | | 27 | | us |
| tD | Delay time | CT = VBIAS | | 29 | | us |
| tD | Delay time | CT = GND | | 29 | | us |
| tFALL | Fall time | CT = Open | | 10 | | us |
| tOFF | Turn OFF time | CT = Open | | 4 | | us |
| VIN = 0.285 V | | | | | | |
| tON | Turn ON time | CT = Open | | 37 | | us |
| tON | Turn ON time | CT = VBIAS | | 96 | | us |
| tON | Turn ON time | CT = GND | | 158 | | us |
| tRISE | Rise time | CT = Open | | 11 | | us |
| tRISE | Rise time | CT = VBIAS | | 66 | | us |
| tRISE | Rise time | CT = GND | | 128 | | us |
| tD | Delay time | CT = Open | | 27 | | us |
| tD | Delay time | CT = VBIAS | | 29 | | us |
| tD | Delay time | CT = GND | | 30 | | us |
| tFALL | Fall time | CT = Open | | 9 | | us |
| tOFF | Turn OFF time | CT = Open | | 4 | | us |

6.9 Timing Diagram

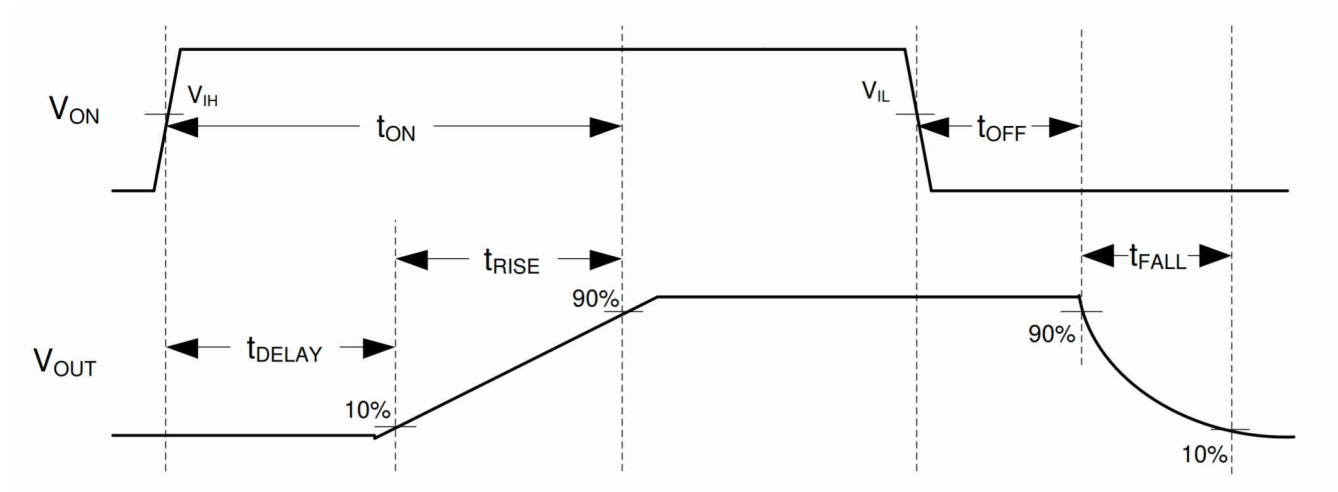

Figure 6-1. TPS22998 Timing Diagram

6.10 Typical Characteristics

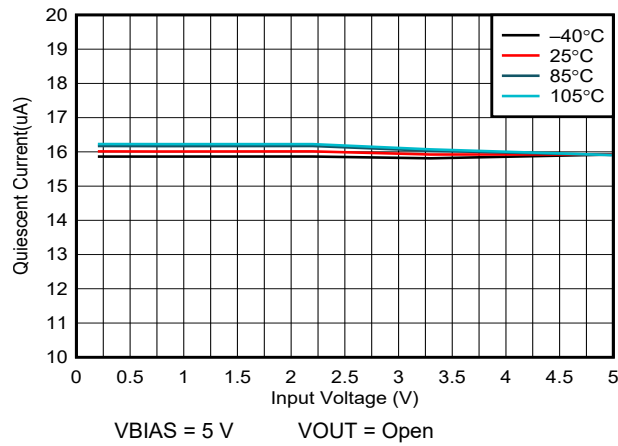

Figure 6-2. Quiescent Current vs Input Voltage

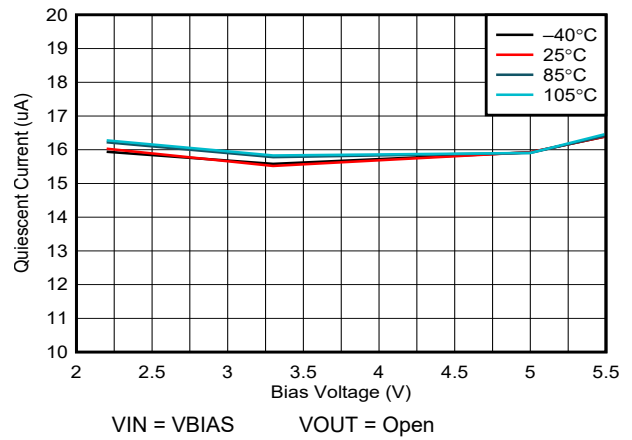

Figure 6-3. Quiescent Current vs Bias Voltage

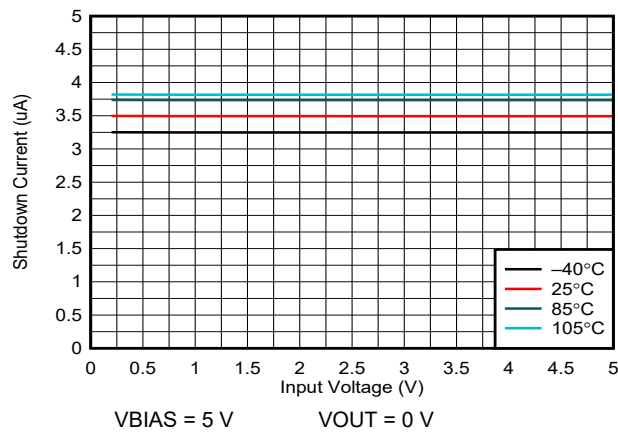

Figure 6-4. VBIAS Shutdown Current vs Input Voltage

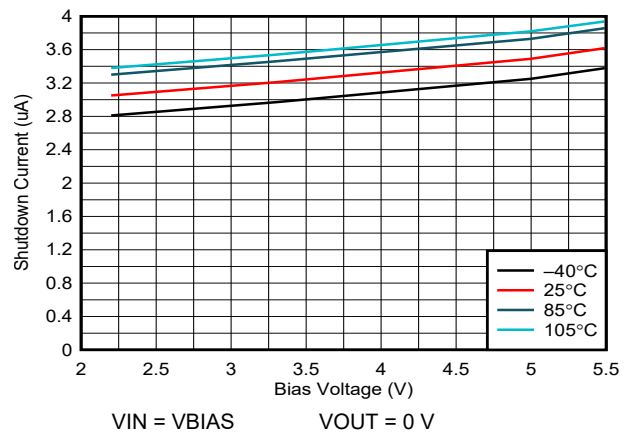

Figure 6-5. VBIAS Shutdown Current vs Bias Voltage

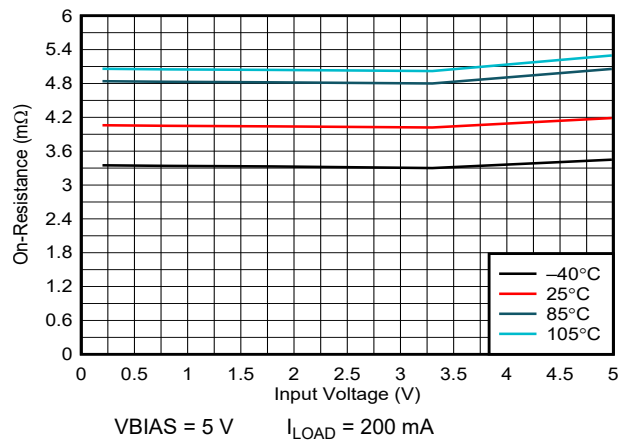

Figure 6-6. On-Resistance vs Input Voltage

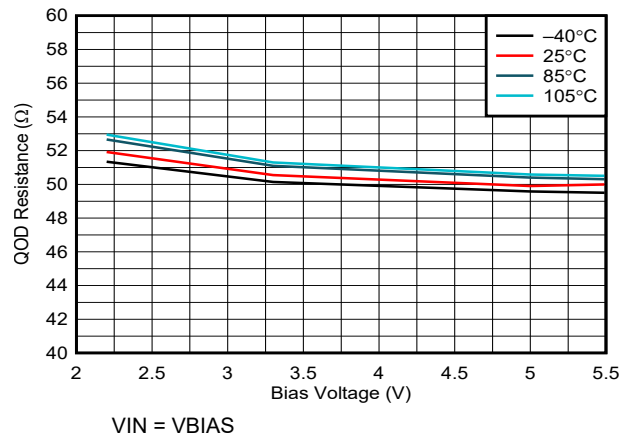
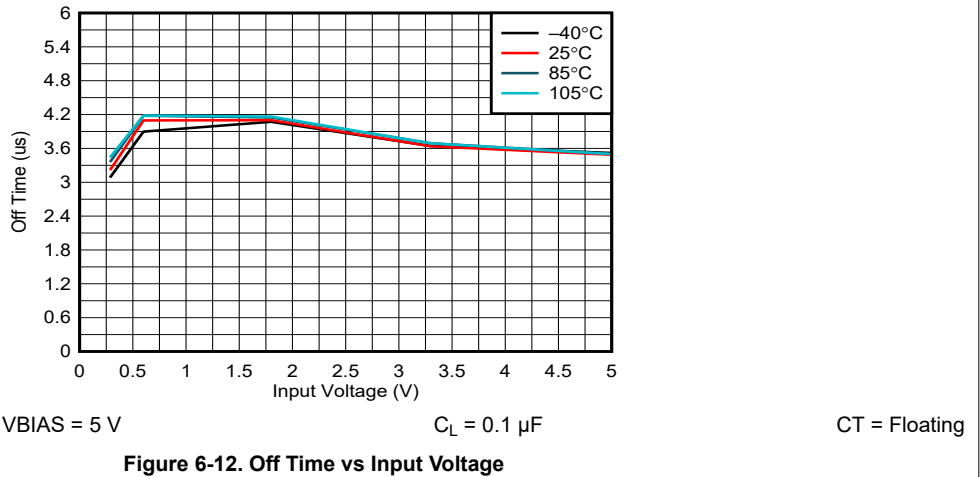
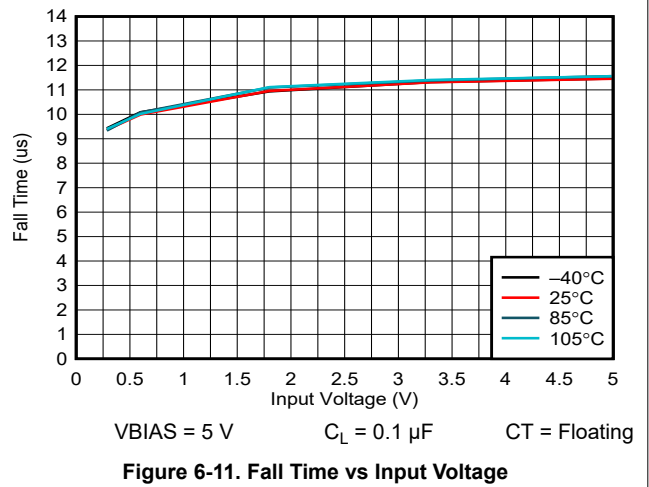
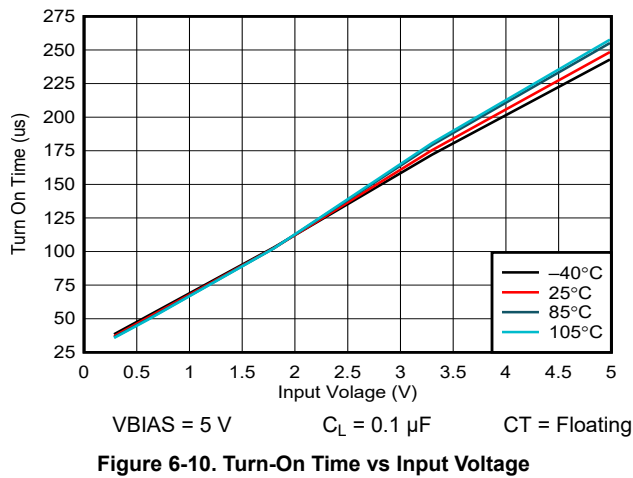
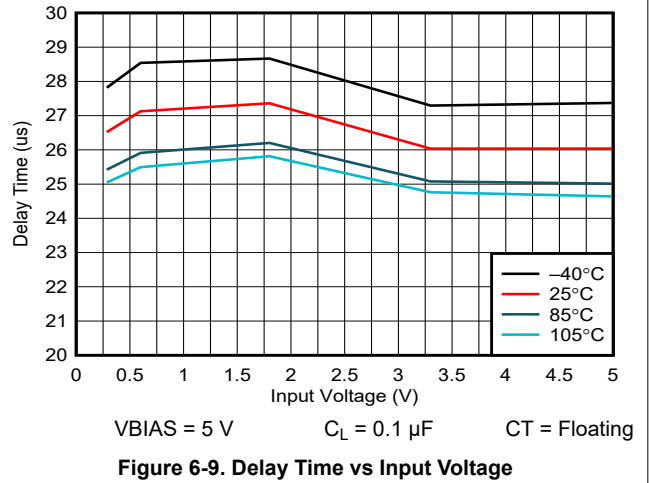
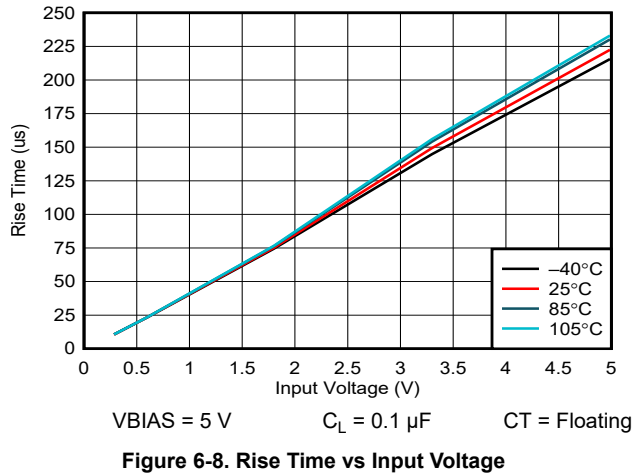

Figure 6-7. QOD Resistance vs Bias Voltage

6.10 Typical Characteristics (continued)



7 Detailed Description

7.1 Overview

The TPS22998 device is a single-channel load switch with a 4-mΩ power MOSFET designed to operate up to 10 A. The voltage range is 0.2 V to 5.5 V. A configurable rise time provides flexibility for power sequencing and minimizes inrush current for high capacitance loads.

An enable pin (ON) controls the switch, which is capable of interfacing directly with low voltage GPIO signals. The TPS22998 device uses quick output discharge when switch turns off, pulling the output down to 0 V through an internal 50-Ω resistor.

7.2 Functional Block Diagram

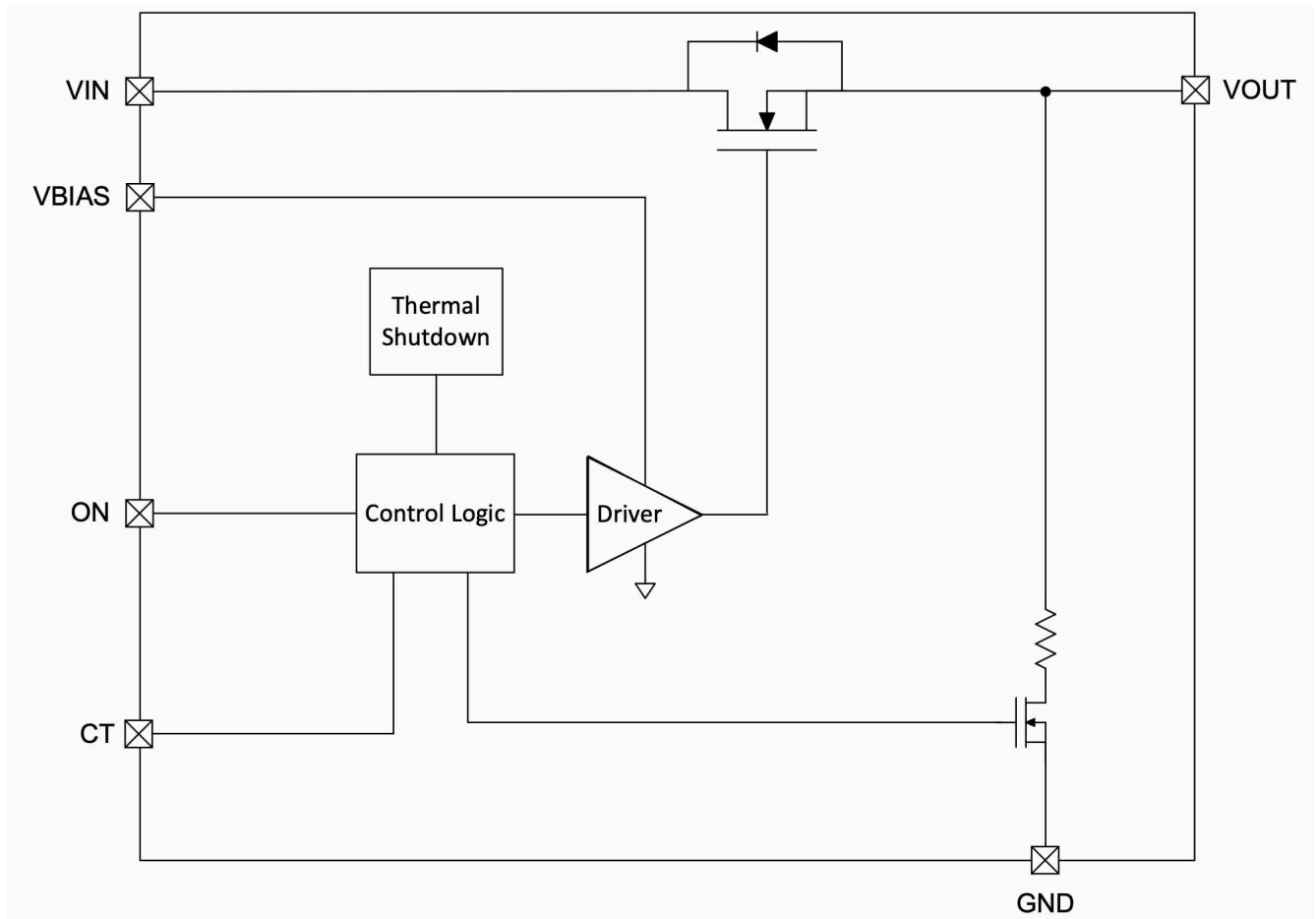

7.3 Feature Description

7.3.1 ON and OFF Control

The ON pin controls the state of the switch. The ON pin is compatible with standard GPIO logic threshold so it can be used in a wide variety of applications. When the pin pull high, the device enables, and when it is low, the device disables.

7.3.2 Adjustable Slew Rate

The CT pin is a tri-state pin, meaning that it has three different slew rates depending on the connection to the pin. The CT pin can be grounded, pulled high, or left floating. Floating defines as an effective resistance to GND or other pins greater than 10 MΩ.

7.3.3 Thermal Shutdown

When the device temperature reaches 150°C (typical), the device shuts itself off to prevent thermal damage. After it cools off by about 20°C, the device turns back on. If the device is kept in a thermally stressful environment, then the device oscillates between these two states until it can keep its temperature below the thermal shutdown point.

7.4 Device Functional Modes

The below table summarizes the device functional modes:

| ON | Fault Condition | VOUT State |
|----|------------------|------------------|
| L | None | QOD to GND |
| H | None | Connected to VIN |
| H | Thermal shutdown | QOD to GND |

8 Application and Implementation

Note

Information in the following applications sections is not part of the TI component specification, and TI does not warrant its accuracy or completeness. TI's customers are responsible for determining suitability of components for their purposes, as well as validating and testing their design implementation to confirm system functionality.

8.1 Application Information

This section highlights some of the design considerations when implementing this device in various applications.

8.2 Typical Application

This typical application demonstrates how to use the TPS22998 device to limit startup inrush current.

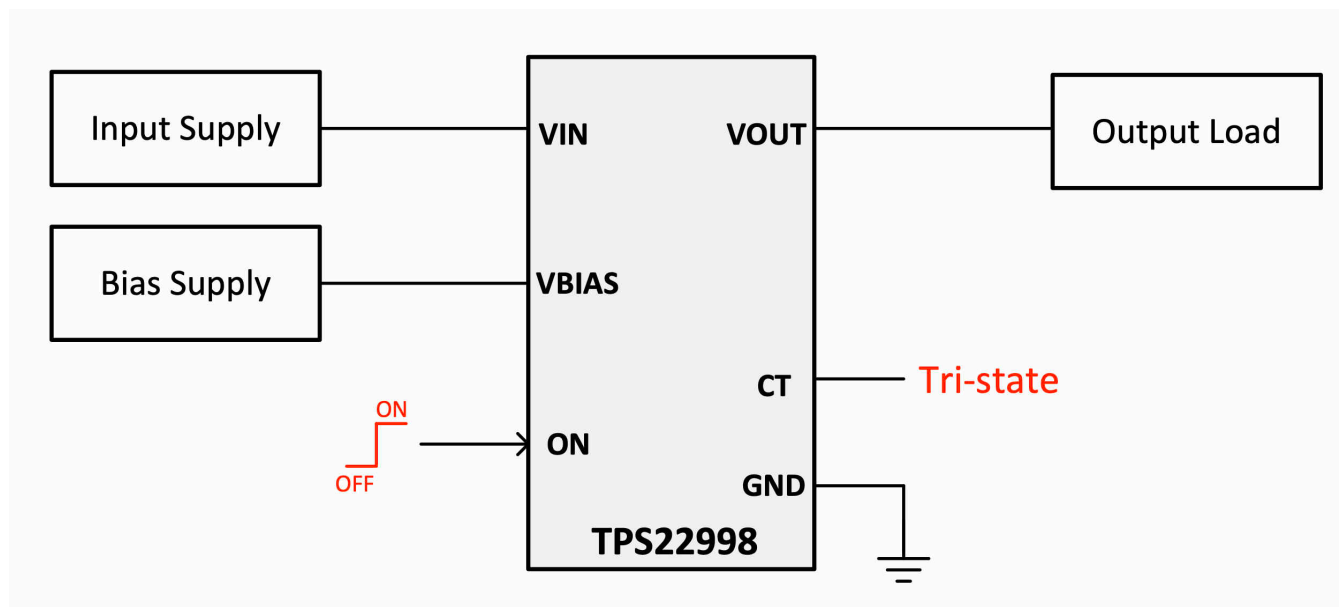

Figure 8-1. TPS22998 Basic Application

8.2.1 Design Requirements

For this example, the values below are used as the design parameters.

Table 8-1. Design Parameters

| PARAMETER | VALUE |
|------------------------|-------------|
| V_{BIAS} | 3.3 V |
| V_{IN} | 1.8 V |
| Load capacitance | 470 μ F |
| Maximum inrush current | 1 A |

8.2.2 Detailed Design Procedure

When the switch enables, the charge up the output capacitance from 0 V to the set value (1.8 V in this example). This charge arrives in the form of inrush current. Calculate inrush current using Equation 1.

$$\text{Inrush Current} = C_L \times dV_{OUT}/dt \tag{1}$$

Where:

- C_L is the output capacitance.
- dV_{OUT} is the change in V_{OUT} during the ramp up of the output voltage when device is enabled. Because rise time is 10% of V_{OUT} to 90% of V_{OUT} , this is 80% of the V_{IN} value.
- dt is the rise time in V_{OUT} during the ramp up of the output voltage when the device is enabled.

The TPS22998 offers an adjustable rise time for V_{OUT} , allowing the user to control the inrush current during turn on. Calculate the appropriate rise time using the design requirements and the inrush current equation as shown below.

$$1A = 470 \mu F \times (1.8 V \times 80\%) / dt \tag{2}$$

$$dt = 677 \mu s \tag{3}$$

To ensure an inrush current of less than 1 A, a C_T setting that yields a rise time of more than 677 μs must be chosen. By pulling the C_T pin high, a rise time of 900 μs is selected, limiting the inrush current to below 1 A.

8.2.3 Application Performance Plots

The below scope shot shows the TPS22998 turning on into a 470- μF load with the C_T pin tied to V_{BIAS} .

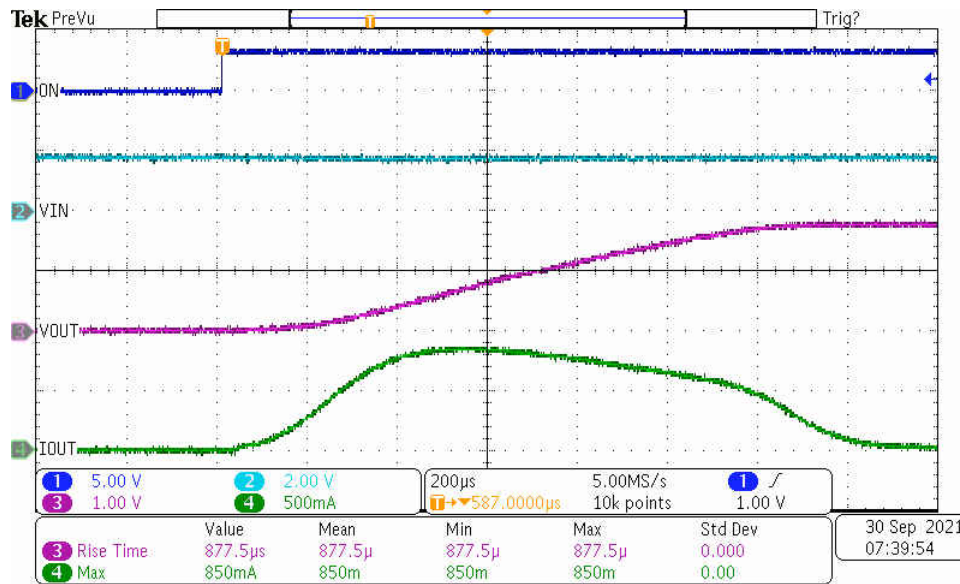

Figure 8-2. TPS22998 Turn-On into 470 μF ($C_T = V_{BIAS}$)

9 Power Supply Recommendations

The TPS22998 device is designed to operate with a V_{IN} range of 0.2 V to 5.5 V. Regulate the V_{IN} power supply well and place as close to the device terminal as possible. The power supply must be able to withstand all transient load current steps. In most situations, using an input capacitance (C_{IN}) of 1 μF is sufficient to prevent the supply voltage from dipping when the switch is turned on. In cases where the power supply is slow to respond to a large transient current or large load current step, additional bulk capacitance can be required on the input.

10 Layout

10.1 Layout Guidelines

For best performance, all traces must be as short as possible. To be most effective, place the input and output capacitors close to the device to minimize the effects that parasitic trace inductances can have on normal operation. Using wide traces for V_{IN} , V_{OUT} , and GND helps minimize the parasitic electrical effects.

10.2 Layout Example

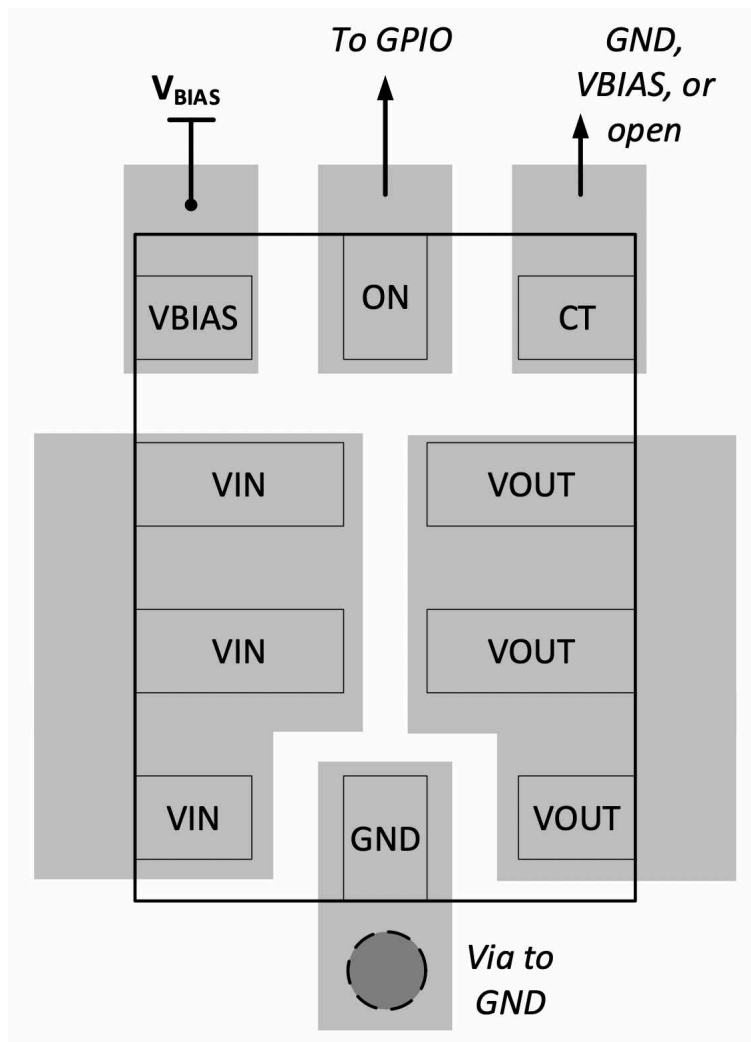

Figure 10-1. TPS22998 Layout Example

11 Device and Documentation Support

TI offers an extensive line of development tools. Tools and software to evaluate the performance of the device, generate code, and develop solutions are listed below.

11.1 Receiving Notification of Documentation Updates

To receive notification of documentation updates, navigate to the device product folder on [ti.com](https://www.ti.com). Click on *Subscribe to updates* to register and receive a weekly digest of any product information that has changed. For change details, review the revision history included in any revised document.

11.2 Support Resources

[TI E2E™ support forums](#) are an engineer's go-to source for fast, verified answers and design help — straight from the experts. Search existing answers or ask your own question to get the quick design help you need.

Linked content is provided "AS IS" by the respective contributors. They do not constitute TI specifications and do not necessarily reflect TI's views; see TI's [Terms of Use](#).

11.3 Trademarks

TI E2E™ is a trademark of Texas Instruments.

All trademarks are the property of their respective owners.

11.4 Electrostatic Discharge Caution



This integrated circuit can be damaged by ESD. Texas Instruments recommends that all integrated circuits be handled with appropriate precautions. Failure to observe proper handling and installation procedures can cause damage.

ESD damage can range from subtle performance degradation to complete device failure. Precision integrated circuits may be more susceptible to damage because very small parametric changes could cause the device not to meet its published specifications.

11.5 Glossary

[TI Glossary](#)

This glossary lists and explains terms, acronyms, and definitions.

12 Mechanical, Packaging, and Orderable Information

The following pages include mechanical, packaging, and orderable information. This information is the most current data available for the designated devices. This data is subject to change without notice and revision of this document. For browser-based versions of this data sheet, refer to the left-hand navigation.

PACKAGING INFORMATION

| Orderable part number | Status (1) | Material type (2) | Package Pins | Package qty Carrier | RoHS (3) | Lead finish/ Ball material (4) | MSL rating/ Peak reflow (5) | Op temp (°C) | Part marking (6) |
|------------------------------|---------------|----------------------|--------------------|-----------------------|-------------|--------------------------------------|-----------------------------------|--------------|---------------------|
| TPS22998RYZR | Active | Production | WQFN-HR (RYZ) 10 | 3000 LARGE T&R | Yes | SN | Level-2-260C-1 YEAR | -40 to 105 | 1LF |
| TPS22998RYZR.A | Active | Production | WQFN-HR (RYZ) 10 | 3000 LARGE T&R | Yes | SN | Level-2-260C-1 YEAR | -40 to 105 | 1LF |

(1) **Status:** For more details on status, see our [product life cycle](#).

(2) **Material type:** When designated, preproduction parts are prototypes/experimental devices, and are not yet approved or released for full production. Testing and final process, including without limitation quality assurance, reliability performance testing, and/or process qualification, may not yet be complete, and this item is subject to further changes or possible discontinuation. If available for ordering, purchases will be subject to an additional waiver at checkout, and are intended for early internal evaluation purposes only. These items are sold without warranties of any kind.

(3) **RoHS values:** Yes, No, RoHS Exempt. See the [TI RoHS Statement](#) for additional information and value definition.

(4) **Lead finish/Ball material:** Parts may have multiple material finish options. Finish options are separated by a vertical ruled line. Lead finish/Ball material values may wrap to two lines if the finish value exceeds the maximum column width.

(5) **MSL rating/Peak reflow:** The moisture sensitivity level ratings and peak solder (reflow) temperatures. In the event that a part has multiple moisture sensitivity ratings, only the lowest level per JEDEC standards is shown. Refer to the shipping label for the actual reflow temperature that will be used to mount the part to the printed circuit board.

(6) **Part marking:** There may be an additional marking, which relates to the logo, the lot trace code information, or the environmental category of the part.

Multiple part markings will be inside parentheses. Only one part marking contained in parentheses and separated by a "~" will appear on a part. If a line is indented then it is a continuation of the previous line and the two combined represent the entire part marking for that device.

Important Information and Disclaimer:The information provided on this page represents TI's knowledge and belief as of the date that it is provided. TI bases its knowledge and belief on information provided by third parties, and makes no representation or warranty as to the accuracy of such information. Efforts are underway to better integrate information from third parties. TI has taken and continues to take reasonable steps to provide representative and accurate information but may not have conducted destructive testing or chemical analysis on incoming materials and chemicals. TI and TI suppliers consider certain information to be proprietary, and thus CAS numbers and other limited information may not be available for release.

In no event shall TI's liability arising out of such information exceed the total purchase price of the TI part(s) at issue in this document sold by TI to Customer on an annual basis.

TAPE AND REEL INFORMATION

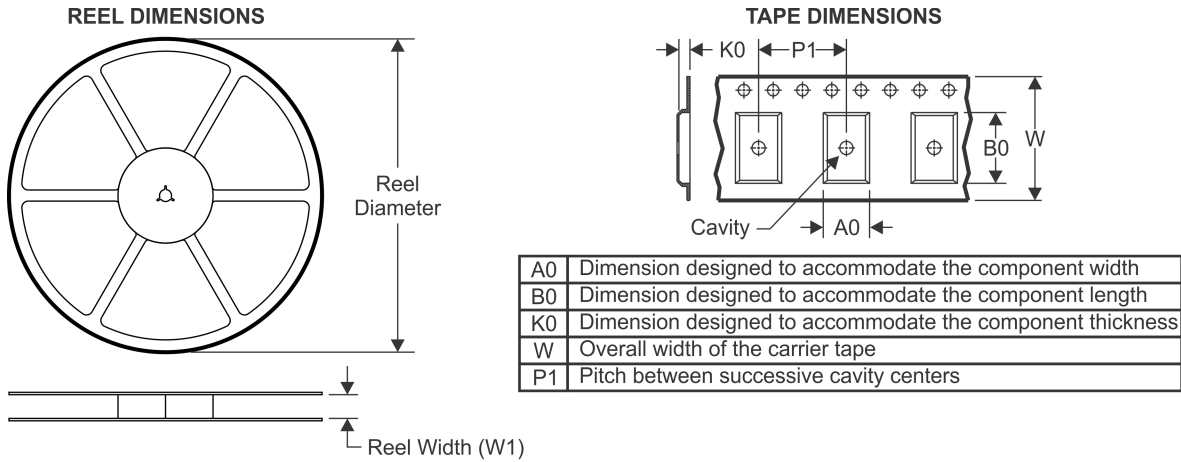

QUADRANT ASSIGNMENTS FOR PIN 1 ORIENTATION IN TAPE

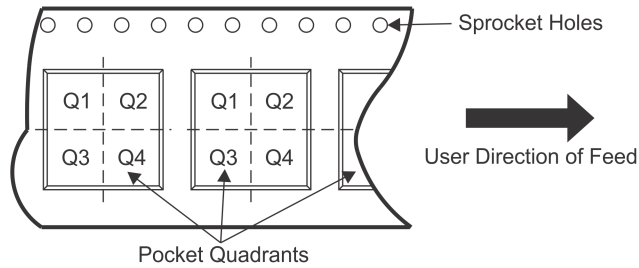

*All dimensions are nominal

| Device | Package Type | Package Drawing | Pins | SPQ | Reel Diameter (mm) | Reel Width W1 (mm) | A0 (mm) | B0 (mm) | K0 (mm) | P1 (mm) | W (mm) | Pin1 Quadrant |
|--------------|--------------|-----------------|------|------|--------------------|--------------------|---------|---------|---------|---------|--------|---------------|
| TPS22998RYZR | WQFN-HR | RYZ | 10 | 3000 | 180.0 | 8.4 | 1.75 | 2.25 | 1.0 | 4.0 | 8.0 | Q1 |

TAPE AND REEL BOX DIMENSIONS

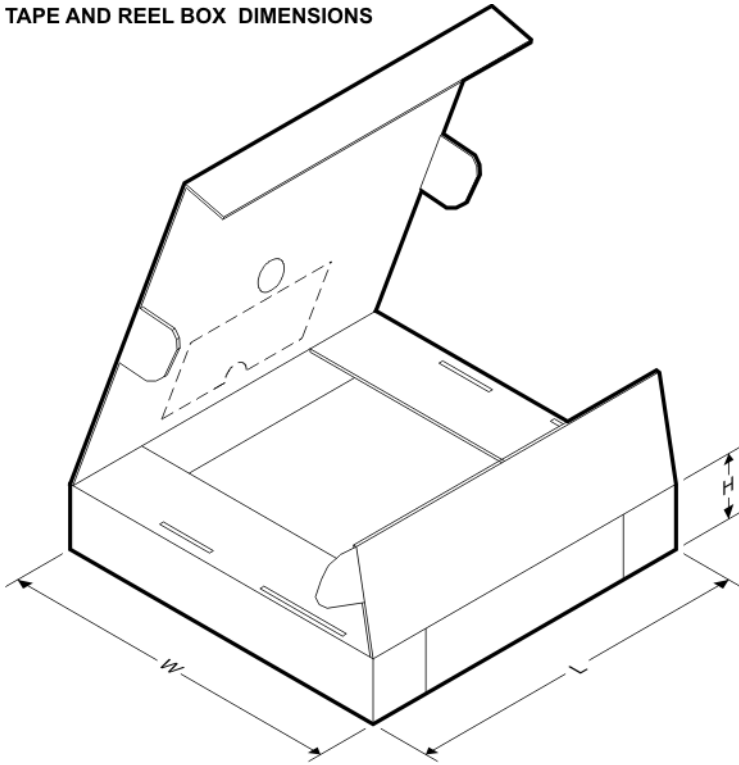

*All dimensions are nominal

| Device | Package Type | Package Drawing | Pins | SPQ | Length (mm) | Width (mm) | Height (mm) |
|--------------|--------------|-----------------|------|------|-------------|------------|-------------|
| TPS22998RYZR | WQFN-HR | RYZ | 10 | 3000 | 210.0 | 185.0 | 35.0 |

RYZ0010A

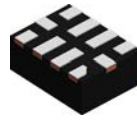

PACKAGE OUTLINE
WQFN-HR - 0.8 mm max height

PLASTIC QUAD FLATPACK - NO LEAD

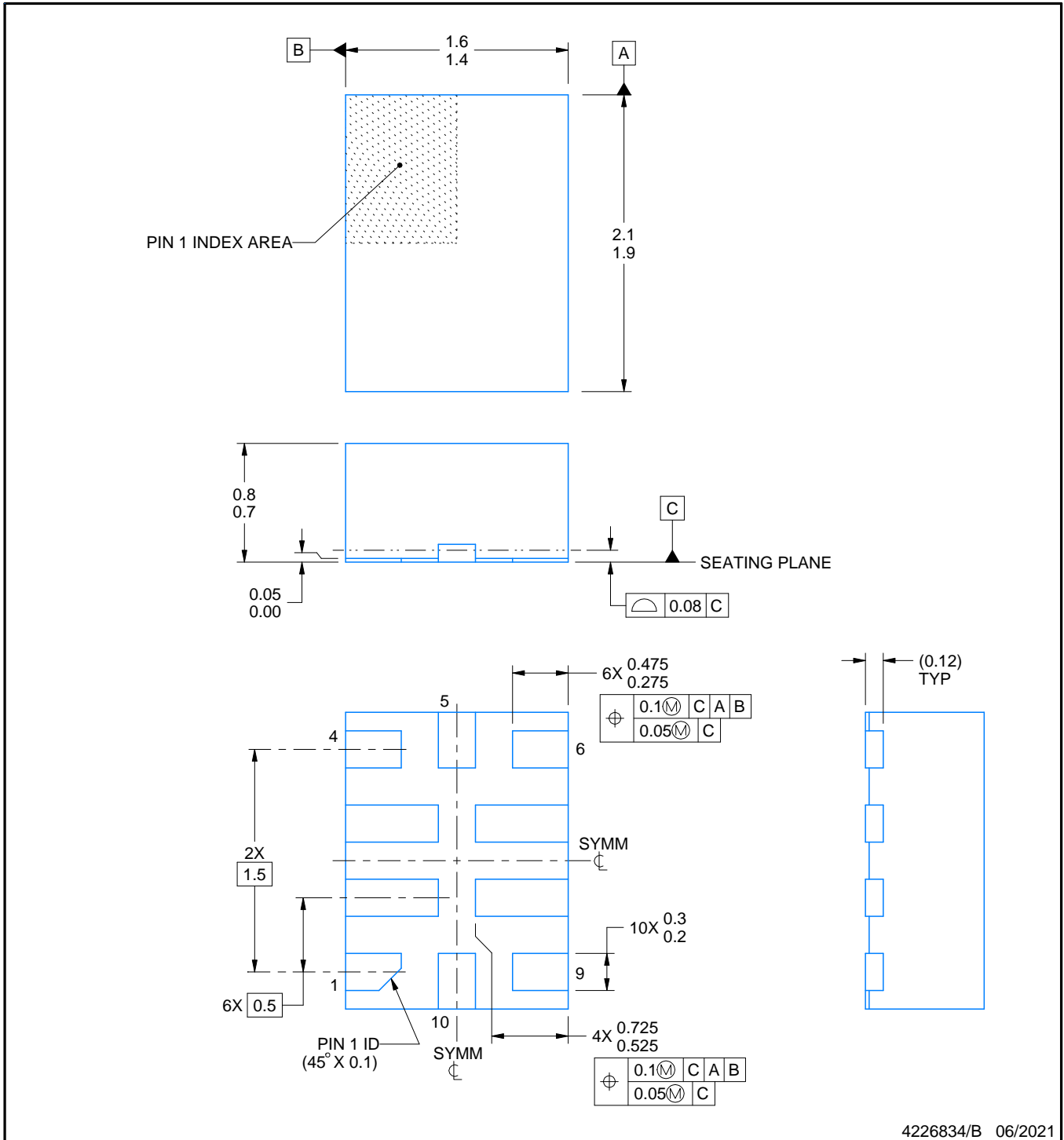

4226834/B 06/2021

NOTES:

- 1. All linear dimensions are in millimeters. Any dimensions in parenthesis are for reference only. Dimensioning and tolerancing per ASME Y14.5M.
- 2. This drawing is subject to change without notice.

EXAMPLE BOARD LAYOUT

RYZ0010A

WQFN-HR - 0.8 mm max height

PLASTIC QUAD FLATPACK - NO LEAD

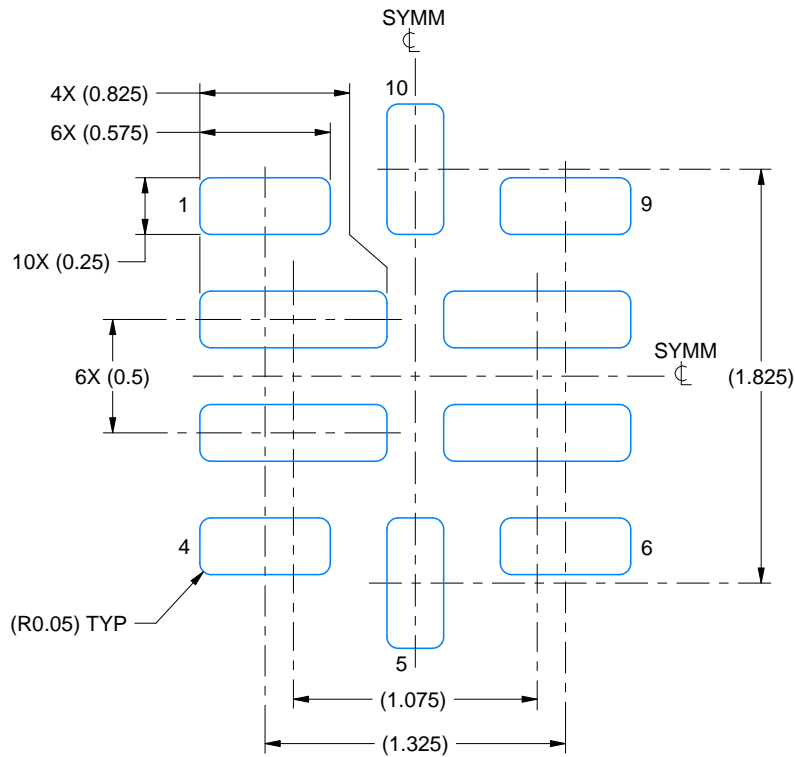

LAND PATTERN EXAMPLE
 EXPOSED METAL SHOWN
 SCALE:30X

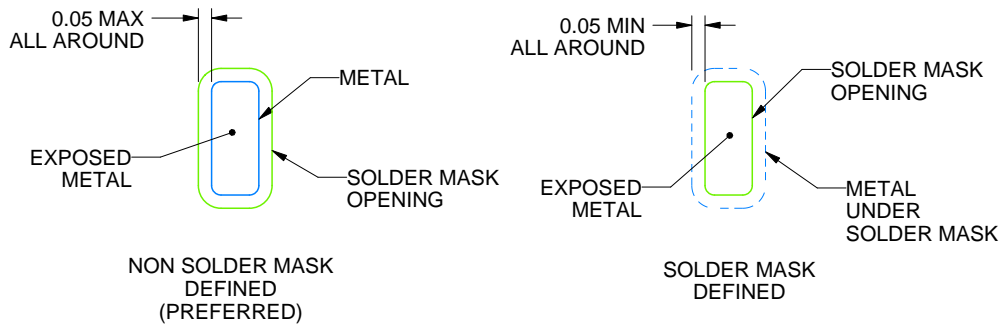

SOLDER MASK DETAILS
 NOT TO SCALE

4226834/B 06/2021

NOTES: (continued)

3. For more information, see Texas Instruments literature number SLUA271 (www.ti.com/lit/slua271).

EXAMPLE STENCIL DESIGN

RYZ0010A

WQFN-HR - 0.8 mm max height

PLASTIC QUAD FLATPACK - NO LEAD

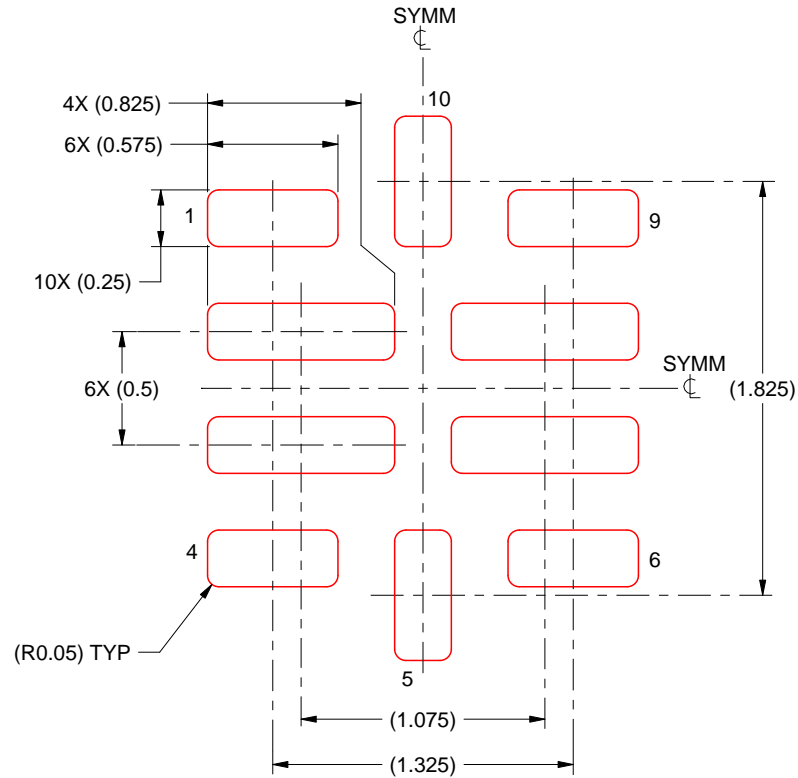

SOLDER PASTE EXAMPLE
BASED ON 0.1 mm THICKNESS
SCALE: 30X

4226834/B 06/2021

NOTES: (continued)

5. Laser cutting apertures with trapezoidal walls and rounded corners may offer better paste release. IPC-7525 may have alternate design recommendations.