

ESD341 1-Channel ± 30 kV ESD Protection Diode in 0201 Package

1 Features

- IEC 61000-4-2 level 4 ESD protection
 - 30 kV contact discharge
 - 30 kV air gap discharge
- IEC 61000-4-5 surge protection
 - 5.4 A (8/20 μ s)
- IO capacitance:
 - 0.66 pF (typical)
- DC breakdown voltage: ± 6.2 V (typical)
- Ultra low leakage current: 100 nA (maximum)
- Low ESD clamping voltage: 10.2 V at 16 A TLP
- Low insertion loss: 5 GHz (-3 dB bandwidth, DPL)
- Supports high speed interfaces up to 3.4 Gbps
- Industrial temperature range: -40°C to $+125^{\circ}\text{C}$
- Space-saving industry standard 0201 footprint (0.6 mm \times 0.3 mm \times 0.3 mm)

2 Applications

- End equipment:
 - Wearables
 - Smart speakers
 - Portable electronics
 - Small appliances
 - Laptops and desktops
 - TV and monitors
 - Head unit
 - Rear seat entertainment
 - Docking stations
- Interfaces:
 - USB 2.0
 - USB 3.0
 - HDMI 1.4 and 2.0
 - LVDS
 - DisplayPort
 - SIM card

3 Description

The ESD341 is a bidirectional TVS ESD protection diode for HDMI 1.4 circuit protection. The ESD341 is rated to dissipate ESD strikes at the maximum level specified in the IEC 61000-4-2 international standard (Level 4).

This device features a 0.66 pF (typical) IO capacitance enabling high-speed interface protection up to 3.4 Gbps including support for protocols such as HDMI 1.4b. The low dynamic resistance and low clamping voltage ensure system level protection against transient events.

The 30 kV ESD rating and 5.4 A surge provides robust transient protection in a tiny package for protecting 3.6 V power rails in portable electronics and other space constrained applications such as wearables.

The ESD341 is offered in the industry standard 0201 (DPL) package.

Device Information⁽¹⁾

| PART NUMBER | PACKAGE | BODY SIZE (NOM) |
|-------------|-----------|--------------------------|
| ESD341 | X2SON (2) | 0.60 mm \times 0.30 mm |

(1) For all available packages, see the orderable addendum at the end of the data sheet.

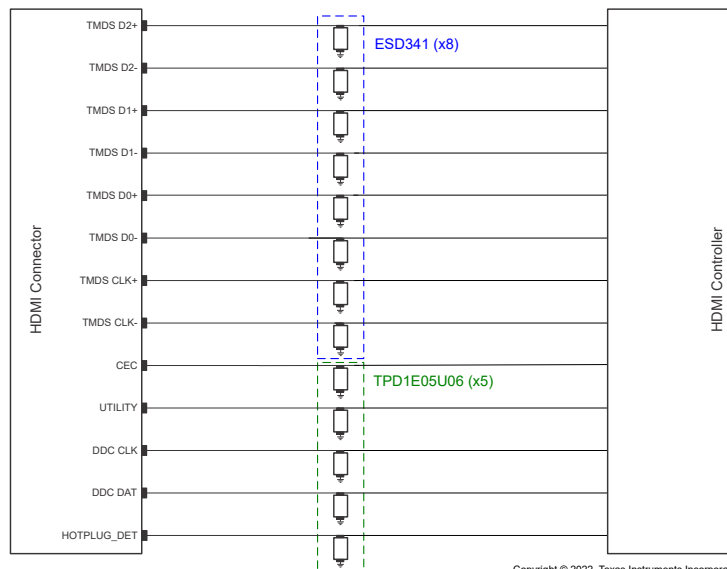

Typical Application

Table of Contents

| | | | |
|--|---|--|----|
| 1 Features | 1 | 8 Application and Implementation | 9 |
| 2 Applications | 1 | 8.1 Application Information..... | 9 |
| 3 Description | 1 | 8.2 Typical Application..... | 9 |
| 4 Revision History | 2 | 9 Power Supply Recommendations | 11 |
| 5 Pin Configuration and Functions | 3 | 10 Layout | 11 |
| 6 Specifications | 4 | 10.1 Layout Guidelines..... | 11 |
| Absolute Maximum Ratings..... | 4 | 10.2 Layout Example..... | 11 |
| 6.1 ESD Ratings—JEDEC Specification..... | 4 | 11 Device and Documentation Support | 12 |
| 6.2 ESD Ratings—IEC Specification..... | 4 | 11.1 Documentation Support..... | 12 |
| Recommended Operating Conditions..... | 4 | 11.2 Receiving Notification of Documentation Updates.. | 12 |
| 6.3 Thermal Information..... | 4 | 11.3 Support Resources..... | 12 |
| 6.4 Electrical Characteristics..... | 5 | 11.4 Trademarks..... | 12 |
| 6.5 Typical Characteristics..... | 6 | 11.5 Electrostatic Discharge Caution..... | 12 |
| 7 Detailed Description | 8 | 11.6 Glossary..... | 12 |
| 7.1 Overview..... | 8 | 12 Mechanical, Packaging, and Orderable | |
| 7.2 Functional Block Diagram..... | 8 | Information | 12 |
| 7.3 Feature Description..... | 8 | 12.1 Tape and Reel Information..... | 14 |
| 7.4 Device Functional Modes..... | 8 | | |

4 Revision History

NOTE: Page numbers for previous revisions may differ from page numbers in the current version.

| Changes from Revision * (April 2022) to Revision A (July 2022) | Page |
|---|-------------|
| • Changed the status of the data sheet from: <i>Advanced Information</i> to: <i>Production Data</i> | 1 |

5 Pin Configuration and Functions

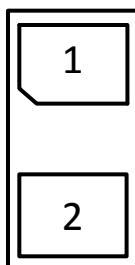

Figure 5-1. DPL Package, 2-Pin X2SON (Top View)

Table 5-1. Pin Functions

| PIN | | TYPE ⁽¹⁾ | DESCRIPTION |
|-----|------|---------------------|---|
| NO. | NAME | | |
| 1 | IO | I/O | ESD Protected Channel. If used as ESD IO, connect pin 2 to ground |
| 2 | IO | I/O | ESD Protected Channel. If used as ESD IO, connect pin 1 to ground |

(1) I = input, O = output

6 Specifications

Absolute Maximum Ratings

over operating free-air temperature range (unless otherwise noted) ⁽¹⁾

| | | MIN | MAX | UNIT |
|-------------------------------|--|-----|-----|------|
| Peak Pulse ^{(2) (3)} | IEC 61000-4-5 power ($t_p - 8/20 \mu s$) | | 54 | W |
| | IEC 61000-4-5 Current ($t_p - 8/20 \mu s$) | | 5.4 | A |
| T_A | Ambient Operating Temperature | -40 | 125 | °C |
| T_J | Junction Temperature | -40 | 125 | °C |
| T_{stg} | Storage Temperature | -65 | 155 | °C |

- (1) Operation outside the Absolute Maximum Ratings may cause permanent device damage. Absolute maximum ratings do not imply functional operation of the device at these or any other conditions beyond those listed under Recommended Operating Conditions. If briefly operating outside the Recommended Operating Conditions but within the Absolute Maximum Ratings, the device may not sustain damage, but it may not be fully functional. Operating the device in this manner may affect device reliability, functionality, performance, and shorten the device lifetime.
- (2) Voltages are with respect to GND unless otherwise noted.
- (3) Measured at 25°C

6.1 ESD Ratings—JEDEC Specification

| | | | VALUE | UNIT |
|-------------|-------------------------|--|-------|------|
| $V_{(ESD)}$ | Electrostatic discharge | Human body model (HBM), per ANSI/ESDA/ JEDEC JS-001 | ±2500 | V |
| | | Charged device model (CDM), per JEDEC specification JS-002 | ±1000 | V |

6.2 ESD Ratings—IEC Specification

| | | | VALUE | UNIT |
|-------------|-------------------------|---------------------------------|--------|------|
| $V_{(ESD)}$ | Electrostatic discharge | IEC 61000-4-2 contact discharge | ±30000 | V |
| | | IEC 61000-4-2 air-gap discharge | ±30000 | |

Recommended Operating Conditions

over operating free-air temperature range (unless otherwise noted)

| | | | MIN | NOM | MAX | UNIT |
|----------|--------------------------------|--------------------------|------|-----|-----|------|
| V_{IO} | Input pin voltage | Pin 1 to 2 or Pin 2 to 1 | -3.6 | | 3.6 | V |
| T_A | Operating free-air temperature | | -40 | | 125 | °C |

6.3 Thermal Information

| THERMAL METRIC ⁽¹⁾ | | ESD341 | UNIT |
|-------------------------------|--|-------------|------|
| | | DPL (X2SON) | |
| | | 2 PINS | |
| $R_{\theta JA}$ | Junction-to-ambient thermal resistance | 356.8 | °C/W |
| $R_{\theta JC(top)}$ | Junction-to-case (top) thermal resistance | 208.8 | °C/W |
| $R_{\theta JB}$ | Junction-to-board thermal resistance | 136.2 | °C/W |
| Ψ_{JT} | Junction-to-top characterization parameter | 3.0 | °C/W |
| Ψ_{JB} | Junction-to-board characterization parameter | 135.7 | °C/W |
| $R_{\theta JC(bot)}$ | Junction-to-case (bottom) thermal resistance | NA | °C/W |

- (1) For more information about traditional and new thermal metrics, see the [Semiconductor and IC Package Thermal Metrics](#) application report.

6.4 Electrical Characteristics

over operating free-air temperature range (unless otherwise noted) ⁽¹⁾

| PARAMETER | | TEST CONDITION | MIN | TYP | MAX | UNIT |
|--------------------------|--|---|------|------|-----|------|
| V _{RWM} | Reverse stand-off voltage | Pin 1 to Pin 2 or Pin 2 to Pin 1 | -3.6 | | 3.6 | V |
| V _{BRF} | Break-down voltage | I _{IO} = 1 mA, Pin 1 to Pin 2 | 5 | 6.2 | 7.2 | V |
| V _{BRR} | Break-down voltage | I _{IO} = -1 mA, Pin 2 to Pin 1 | -7.2 | -6.2 | -5 | V |
| V _{HOLD} | Holding voltage ⁽²⁾ | TLP, Pin 1 to Pin 2 or Pin 2 to Pin 1 | | 6.2 | | V |
| V _{Clamp_TLP} | Clamp voltage with TLP ⁽²⁾ | I _{PP} = 1 A, TLP, Pin 1 to Pin 2 | | 6.3 | | V |
| | | I _{PP} = 5 A, TLP, Pin 1 to Pin 2 | | 7.4 | | |
| | | I _{PP} = 16 A, TLP, Pin 1 to Pin 2 | | 10.2 | | |
| | | I _{PP} = 1 A, TLP, Pin 2 to Pin 1 | | 6.3 | | |
| | | I _{PP} = 5 A, TLP, Pin 2 to Pin 1 | | 7.4 | | |
| | | I _{PP} = 16 A, TLP, Pin 2 to Pin 1 | | 10.2 | | |
| V _{Clamp_Surge} | Clamp voltage with surge strike ⁽⁴⁾ | I _{PP} = 5.4 A, t _p = 8/20 μs, Pin 1 to Pin 2 or Pin 2 to Pin 1 | | 8.8 | | V |
| I _{LEAK} | Leakage current | V _{IO} = 3.6 V, Pin 1 to Pin 2 or Pin 2 to Pin 1 | | 5 | 100 | nA |
| R _{DYN} | Dynamic resistance ⁽³⁾ | Pin 1 to Pin 2 | | 0.25 | | Ω |
| | | Pin 2 to Pin 1 | | | | |
| C _L | Line capacitance | V _{IO} = 0 V; f = 1 MHz, Pin 1 to Pin 2, T _A = 25°C | | 0.66 | | pF |

(1) Typical parameters are measured at 25°C

(2) Transition line pulse with 100 ns width and 10 ns rise and fall time

(3) Extraction of R_{DYN} using least squares fit of TLP characteristics between I = 10 A and I = 20 A

(4) Nonrepetitive current pulse 8 to 20 μs exponentially decaying waveform according to IEC 61000-4-5

6.5 Typical Characteristics

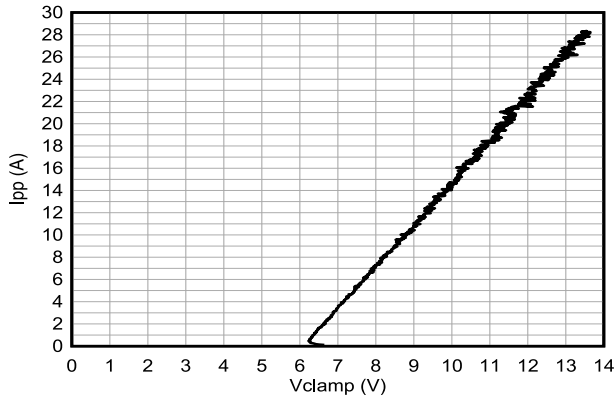

tp = 100 ns, Transmission Line Pulse (TLP)

Figure 6-1. Positive TLP Curve

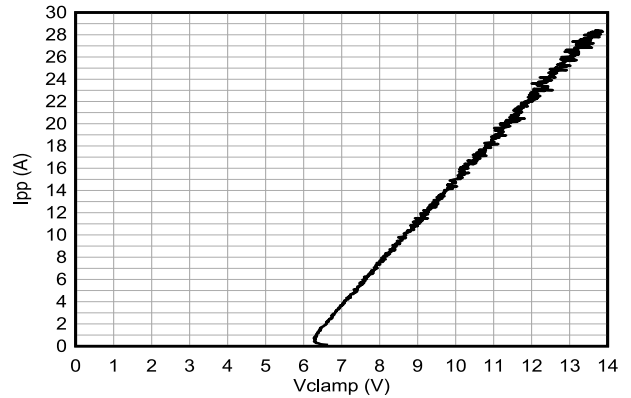

tp = 100 ns, Transmission Line Pulse (TLP)

Figure 6-2. Negative TLP Curve

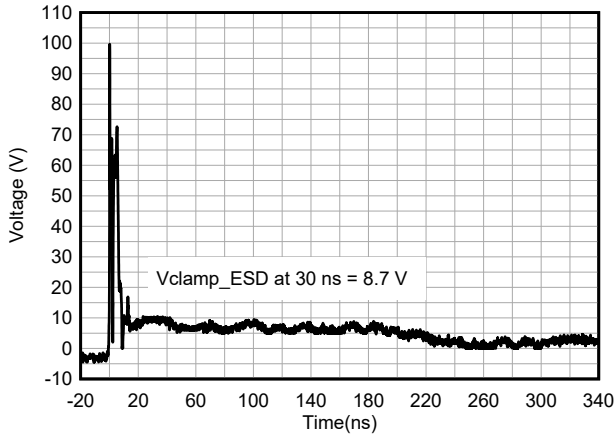

Figure 6-3. +8-kV Clamped IEC Waveform

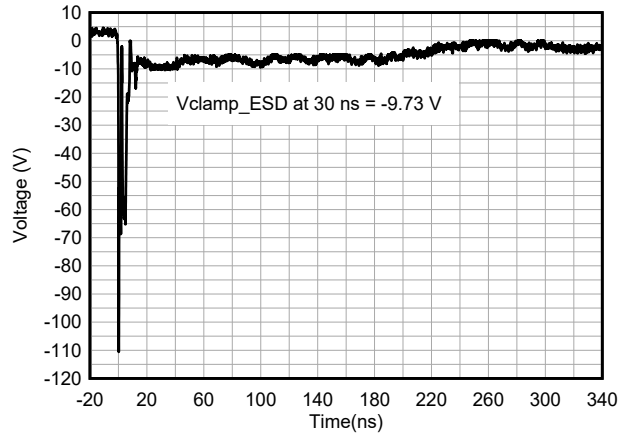

Figure 6-4. -8-kV Clamped IEC Waveform

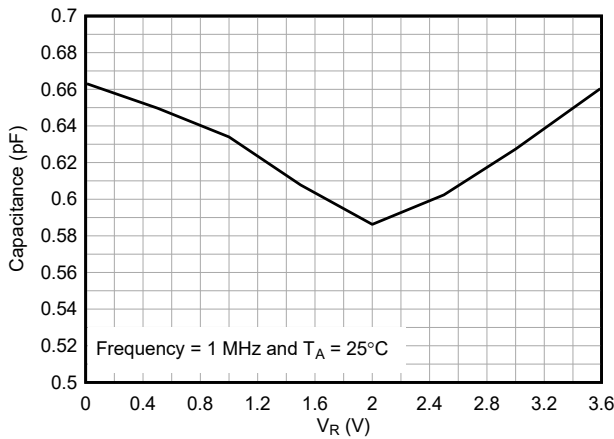

Figure 6-5. Bias Voltage vs. Capacitance

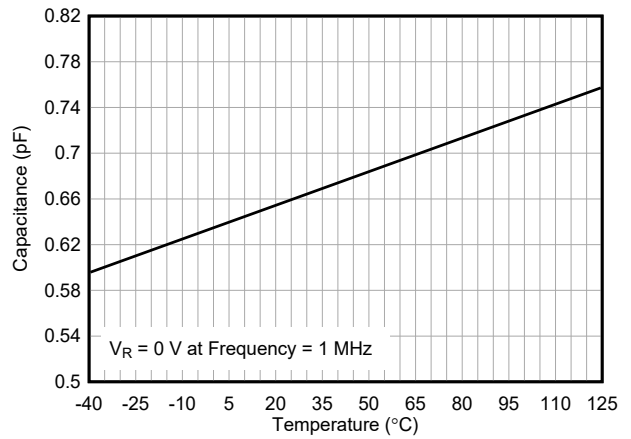
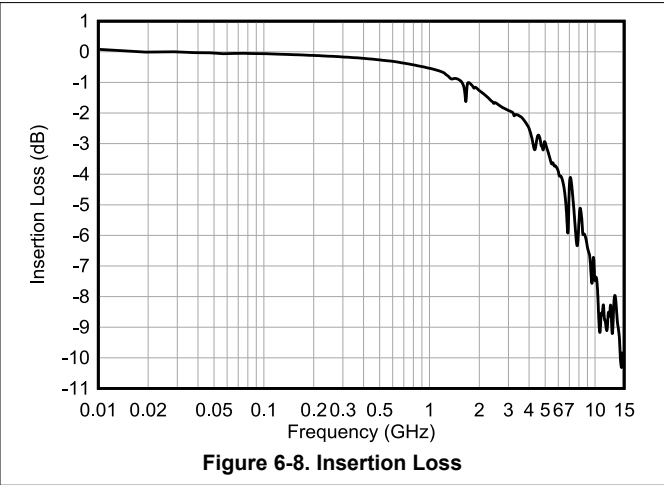
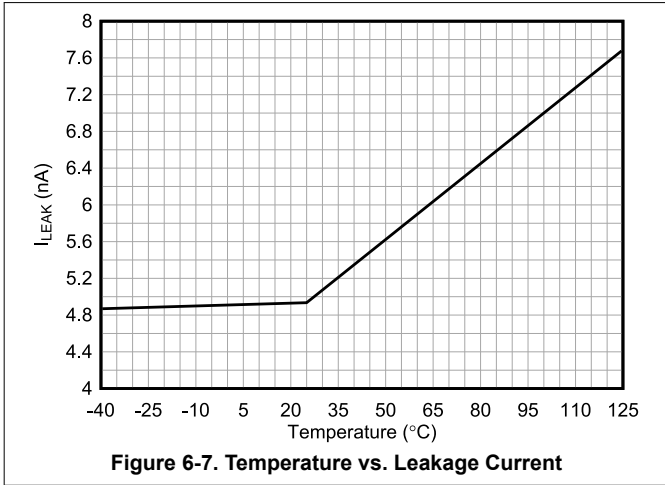

Figure 6-6. Temperature vs. Capacitance

6.5 Typical Characteristics (continued)



7 Detailed Description

7.1 Overview

The ESD341 device is a bidirectional ESD Protection Diode with ultra-low capacitance. This device can dissipate ESD strikes above the maximum level specified by the IEC 61000-4-2 International Standard. The ultra-low capacitance allows this device to protect high-speed signal pins including HDMI 1.4b.

7.2 Functional Block Diagram

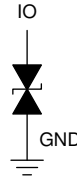

Copyright © 2016, Texas Instruments Incorporated

7.3 Feature Description

7.3.1 IEC 61000-4-2 ESD Protection

The I/O pins can withstand ESD events up to ± 30 kV contact and ± 30 kV air gap. An ESD-surge clamp diverts the current to ground.

7.3.2 IEC 61000-4-5 Surge Protection

The I/O pins can withstand surge events up to 5.4 A and 54 W (8/20 μ s waveform). An ESD-surge clamp diverts this current to ground.

7.3.3 IO Capacitance

The capacitance between each I/O pin to ground is 0.66 pF (typical). This device supports data rates up to 3.4 Gbps.

7.3.4 DC Breakdown Voltage

The DC breakdown voltage of each I/O pin is ± 6.2 V (typical). This DC breakdown voltage ensures that sensitive equipment is protected from surges above the reverse standoff voltage of ± 3.6 V.

7.3.5 Ultra Low Leakage Current

The I/O pins feature an ultra-low leakage current of 100 nA (maximum) with a bias of ± 3.6 V.

7.3.6 Low ESD Clamping Voltage

The I/O pins feature an ESD clamp that is capable of clamping the voltage to 7.4 V ($I_{PP} = 5$ A, TLP).

7.3.7 Supports High Speed Interfaces

This device is capable of supporting high speed interfaces up to 3.4 Gbps, because of the extremely low IO capacitance.

7.3.8 Industrial Temperature Range

This device features an industrial operating range of -40°C to $+125^{\circ}\text{C}$.

7.4 Device Functional Modes

The ESD341 device is a passive integrated circuit that triggers when voltages are above V_{BRF} or below V_{BRR} . During ESD events, voltages as high as ± 30 kV (air or contact) can be directed to ground through the internal diode network. When the voltages on the protected line fall below the V_{HOLD} of ESD341 (usually within 10s of nano-seconds) the device reverts to passive.

8 Application and Implementation

Note

Information in the following applications sections is not part of the TI component specification, and TI does not warrant its accuracy or completeness. TI's customers are responsible for determining suitability of components for their purposes, as well as validating and testing their design implementation to confirm system functionality.

8.1 Application Information

The ESD341 is a diode type TVS which provides a path to ground for dissipating ESD events on high-speed signal lines between a human interface connector and a system. As the current from ESD passes through the TVS, only a small voltage drop is present across the diode. This is the voltage presented to the protected IC. The low R_{DYN} of the triggered TVS holds this voltage (V_{CLAMP}) to a safe level for the protected IC.

8.2 Typical Application

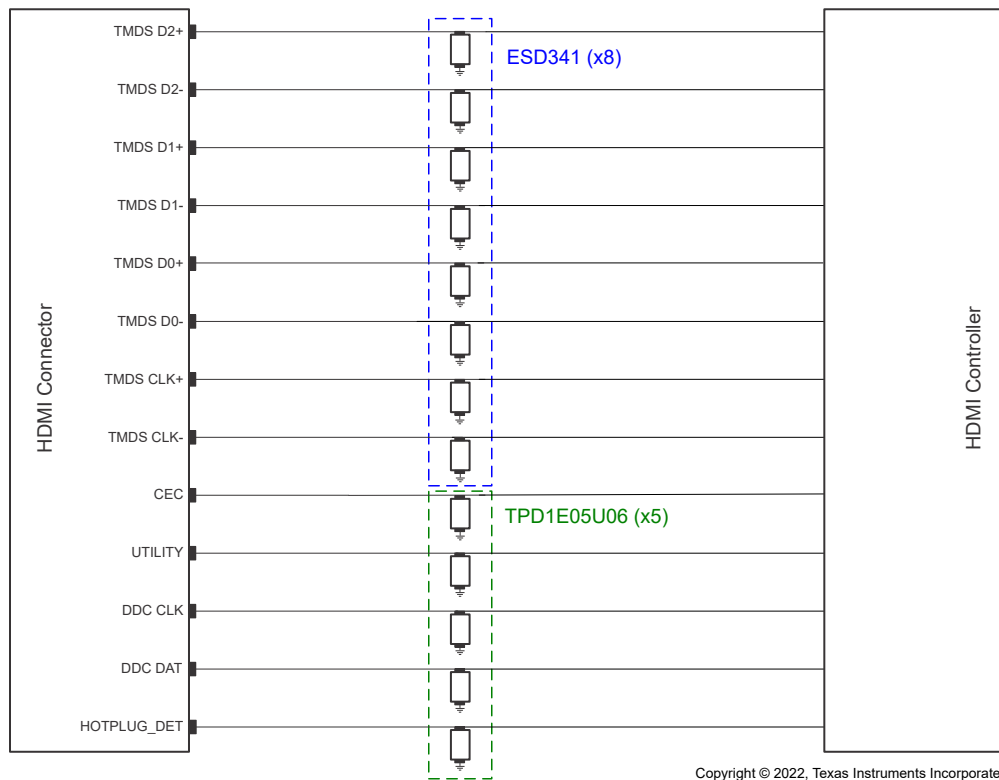

Figure 8-1. HDMI 1.4 Application

8.2.1 Design Requirements

For this design example, 8 ESD341 devices and 5 TPD1E05U06 devices are being used in an HDMI 1.4 application, which provides a complete port protection scheme.

Table 8-1 lists the parameters for the HDMI 1.4 application.

Table 8-1. Design Parameters

| DESIGN PARAMETER | VALUE |
|----------------------------|--------------|
| TMDS signal range on pins | 0 V to 3.6 V |
| Other signal range on pins | 0 V to 5 V |
| Operating frequency | 1.7 GHz |

8.2.2 Detailed Design Procedure

8.2.2.1 Signal Range

The ESD341 supports signal ranges between -3.6 V and 3.6 V , which supports the TMDS signals. The TPD1E05U06 supports signal ranges between 0 V and 5.5 V , which supports the other signals (CEC, UTILITY, DDC CLK, DDC DAT, and HOTPLUG_DET) in the HDMI 1.4 application.

8.2.2.2 Operating Frequency

The ESD341 has a 0.66 pF (typical) capacitance, which supports the 3.4 Gbps data rate needed for the HDMI 1.4 application.

8.2.3 Application Curves

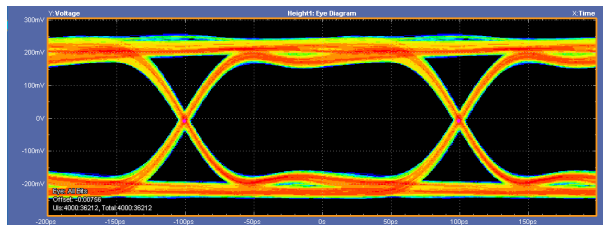

Figure 8-2. Data Rate > 3.4 Gbps Eye Diagram (Bare Board)

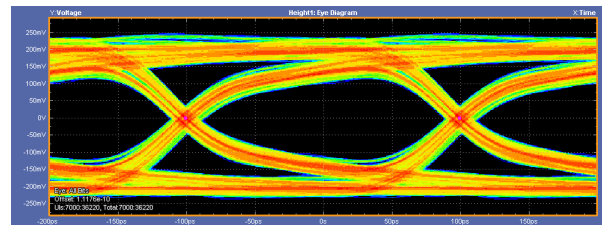

Figure 8-3. Data Rate > 3.4 Gbps Eye Diagram (with ESD341)

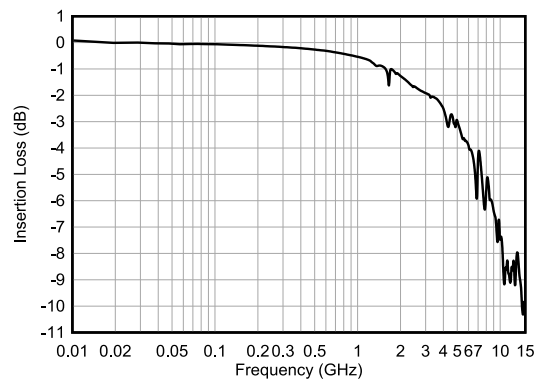

Figure 8-4. Insertion Loss

9 Power Supply Recommendations

This is a passive TVS diode-based ESD protection device, therefore there is no need to power it. Take care that the maximum voltage specifications for each pin are not violated.

10 Layout

10.1 Layout Guidelines

- The optimum placement of the ESD protection device is as close to the connector as possible
 - EMI during an ESD event can couple from the trace being struck to other nearby unprotected traces, resulting in early system failures
 - The PCB designer must minimize the possibility of EMI coupling by keeping any unprotected traces away from the protected traces which are between the TVS and the connector
- Route the protected traces as straight as possible
- Eliminate any sharp corners on the protected traces between the TVS and the connector by using rounded corners with the largest radii possible
 - Electric fields tend to build up on corners, increasing EMI coupling
- If pin 1 or pin 2 is connected to ground, use a thick and short trace for this return path

10.2 Layout Example

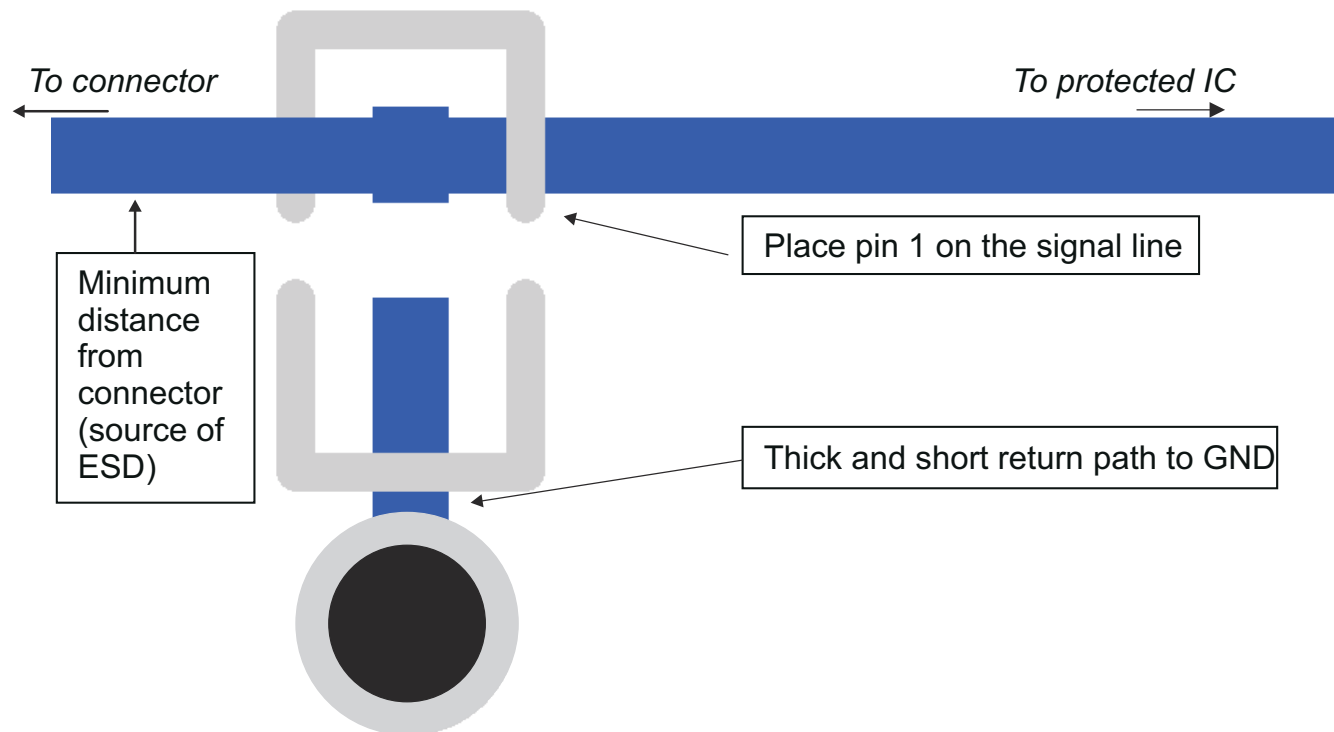

Figure 10-1. Layout Recommendation

11 Device and Documentation Support

11.1 Documentation Support

11.1.1 Related Documentation

For related documentation, see the following:

- Texas Instruments, [ESD Layout Guide application reports](#)
- Texas Instruments, [Generic ESD Evaluation Module user's guide](#)
- Texas Instruments, [Picking ESD Diodes for Ultra High-Speed Data Lines application reports](#)
- Texas Instruments, [Reading and Understanding an ESD Protection data sheet](#)

11.2 Receiving Notification of Documentation Updates

To receive notification of documentation updates, navigate to the device product folder on [ti.com](https://www.ti.com). Click on *Subscribe to updates* to register and receive a weekly digest of any product information that has changed. For change details, review the revision history included in any revised document.

11.3 Support Resources

[TI E2E™ support forums](#) are an engineer's go-to source for fast, verified answers and design help — straight from the experts. Search existing answers or ask your own question to get the quick design help you need.

Linked content is provided "AS IS" by the respective contributors. They do not constitute TI specifications and do not necessarily reflect TI's views; see TI's [Terms of Use](#).

11.4 Trademarks

TI E2E™ is a trademark of Texas Instruments.

All trademarks are the property of their respective owners.

11.5 Electrostatic Discharge Caution



This integrated circuit can be damaged by ESD. Texas Instruments recommends that all integrated circuits be handled with appropriate precautions. Failure to observe proper handling and installation procedures can cause damage.

ESD damage can range from subtle performance degradation to complete device failure. Precision integrated circuits may be more susceptible to damage because very small parametric changes could cause the device not to meet its published specifications.

11.6 Glossary

[TI Glossary](#) This glossary lists and explains terms, acronyms, and definitions.

12 Mechanical, Packaging, and Orderable Information

The following pages include mechanical, packaging, and orderable information. This information is the most current data available for the designated devices. This data is subject to change without notice and revision of this document. For browser-based versions of this data sheet, refer to the left-hand navigation.

MECHANICAL DATA

DPL (R-PX2SON-N2)

PLASTIC SMALL OUTLINE NO-LEAD

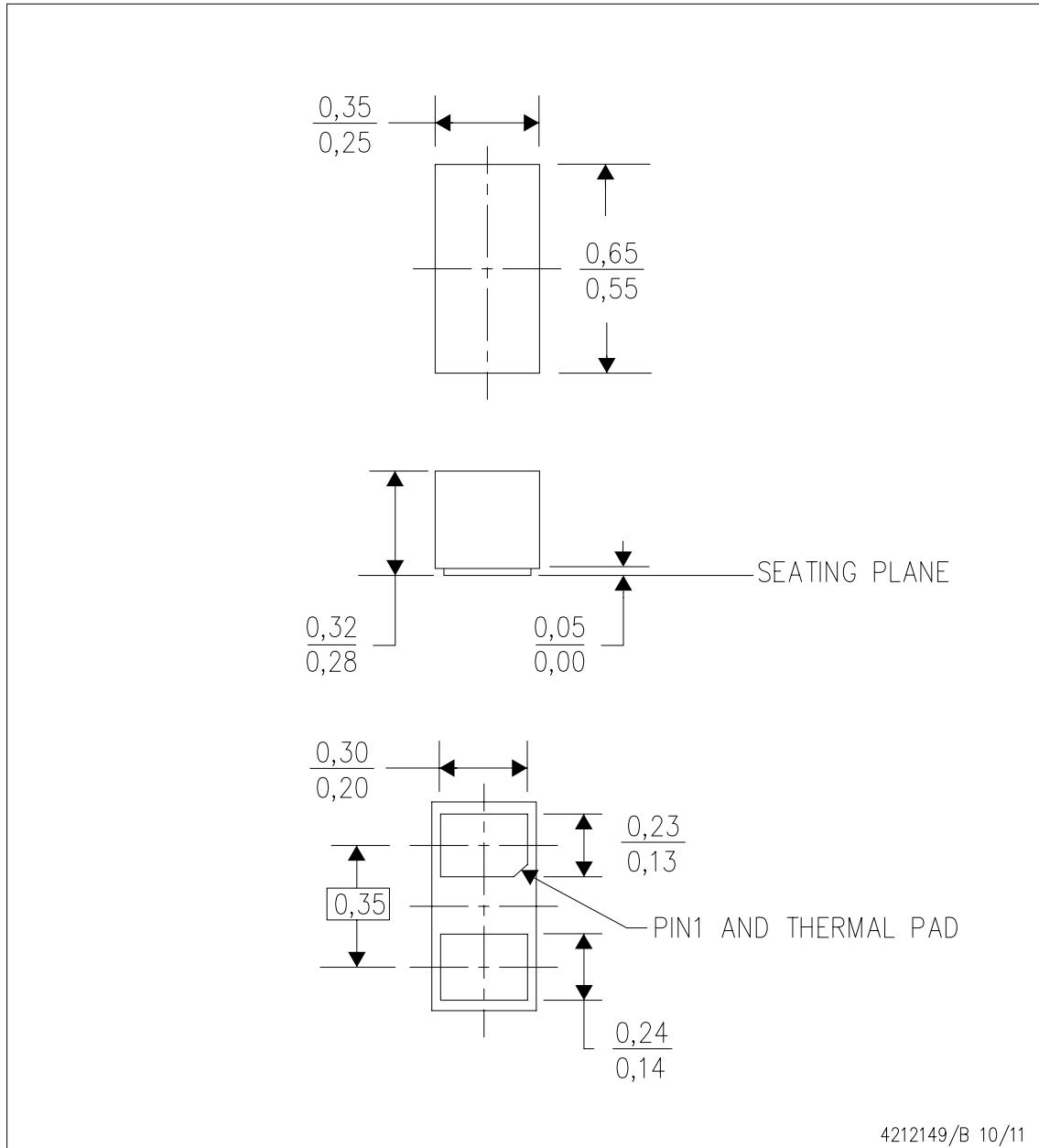

- NOTES:
- All linear dimensions are in millimeters. Dimensioning and tolerancing per ASME Y14.5M-1994.
 - This drawing is subject to change without notice.
 - Small Outline No-Lead (SON) package configuration.
 - The package thermal pad must be soldered to the board for thermal and mechanical performance.

12.1 Tape and Reel Information

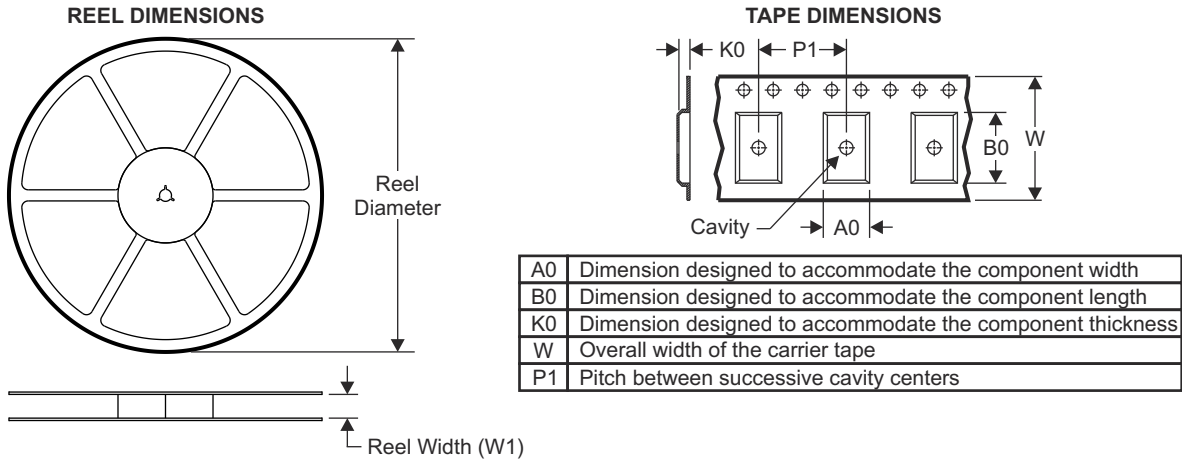

QUADRANT ASSIGNMENTS FOR PIN 1 ORIENTATION IN TAPE

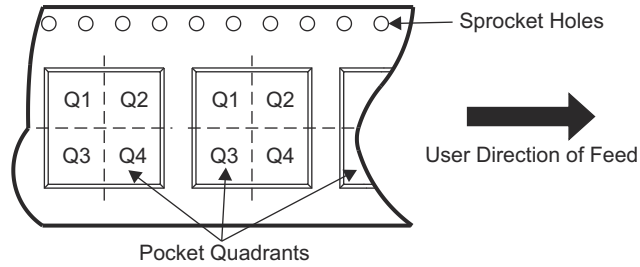

| Device | Package Type | Package Drawing | Pins | SPQ | Reel Diameter (mm) | Reel Width W1 (mm) | A0 (mm) | B0 (mm) | K0 (mm) | P1 (mm) | W (mm) | Pin1 Quadrant |
|------------|--------------|-----------------|------|-------|--------------------|--------------------|---------|---------|---------|---------|--------|---------------|
| ESD341DPLR | X2SON | DPL | 2 | 15000 | 178 | 8.4 | 0.36 | 0.66 | 0.33 | 0.2 | 8 | Q1 |

TAPE AND REEL BOX DIMENSIONS

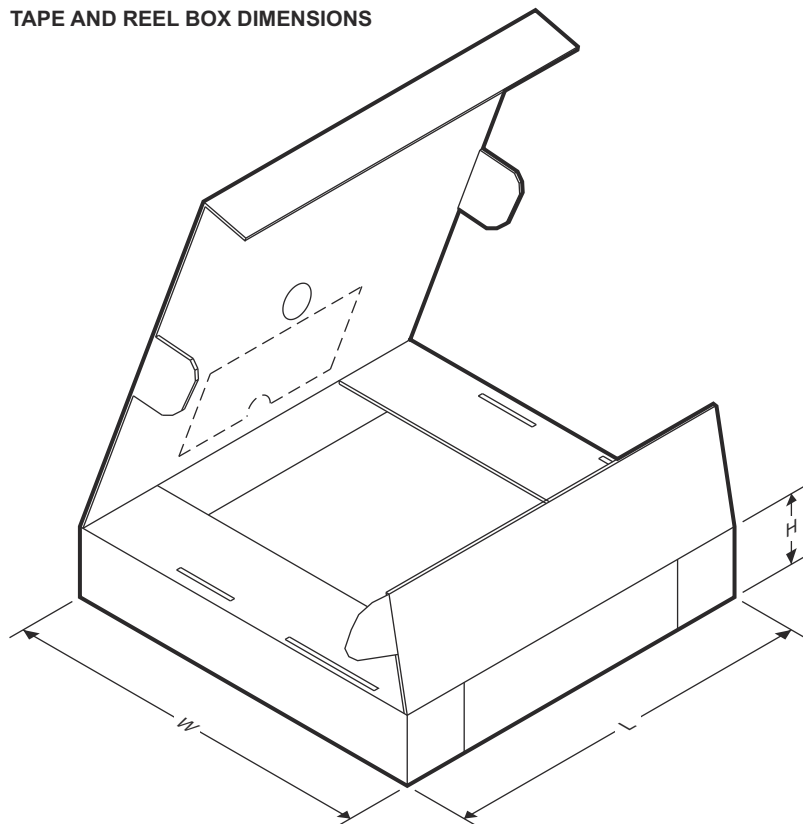

| Device | Package Type | Package Drawing | Pins | SPQ | Length (mm) | Width (mm) | Height (mm) |
|------------|--------------|-----------------|------|-------|-------------|------------|-------------|
| ESD341DPLR | X2SON | DPL | 2 | 15000 | 205 | 200 | 33 |

PACKAGING INFORMATION

| Orderable part number | Status (1) | Material type (2) | Package Pins | Package qty Carrier | RoHS (3) | Lead finish/ Ball material (4) | MSL rating/ Peak reflow (5) | Op temp (°C) | Part marking (6) |
|----------------------------|---------------|----------------------|-----------------|-----------------------|-------------|--------------------------------------|-----------------------------------|--------------|---------------------|
| ESD341DPLR | Active | Production | X2SON (DPL) 2 | 15000 LARGE T&R | Yes | NIPDAU | Level-1-260C-UNLIM | -40 to 125 | 3 |
| ESD341DPLR.B | Active | Production | X2SON (DPL) 2 | 15000 LARGE T&R | Yes | NIPDAU | Level-1-260C-UNLIM | -40 to 125 | 3 |

(1) **Status:** For more details on status, see our [product life cycle](#).

(2) **Material type:** When designated, preproduction parts are prototypes/experimental devices, and are not yet approved or released for full production. Testing and final process, including without limitation quality assurance, reliability performance testing, and/or process qualification, may not yet be complete, and this item is subject to further changes or possible discontinuation. If available for ordering, purchases will be subject to an additional waiver at checkout, and are intended for early internal evaluation purposes only. These items are sold without warranties of any kind.

(3) **RoHS values:** Yes, No, RoHS Exempt. See the [TI RoHS Statement](#) for additional information and value definition.

(4) **Lead finish/Ball material:** Parts may have multiple material finish options. Finish options are separated by a vertical ruled line. Lead finish/Ball material values may wrap to two lines if the finish value exceeds the maximum column width.

(5) **MSL rating/Peak reflow:** The moisture sensitivity level ratings and peak solder (reflow) temperatures. In the event that a part has multiple moisture sensitivity ratings, only the lowest level per JEDEC standards is shown. Refer to the shipping label for the actual reflow temperature that will be used to mount the part to the printed circuit board.

(6) **Part marking:** There may be an additional marking, which relates to the logo, the lot trace code information, or the environmental category of the part.

Multiple part markings will be inside parentheses. Only one part marking contained in parentheses and separated by a "~" will appear on a part. If a line is indented then it is a continuation of the previous line and the two combined represent the entire part marking for that device.

Important Information and Disclaimer:The information provided on this page represents TI's knowledge and belief as of the date that it is provided. TI bases its knowledge and belief on information provided by third parties, and makes no representation or warranty as to the accuracy of such information. Efforts are underway to better integrate information from third parties. TI has taken and continues to take reasonable steps to provide representative and accurate information but may not have conducted destructive testing or chemical analysis on incoming materials and chemicals. TI and TI suppliers consider certain information to be proprietary, and thus CAS numbers and other limited information may not be available for release.

In no event shall TI's liability arising out of such information exceed the total purchase price of the TI part(s) at issue in this document sold by TI to Customer on an annual basis.