

GENERAL DESCRIPTION

The SGM66099A is an ultra-low quiescent current synchronous Boost converter. 0.7V to 5.5V operation input voltage is suitable for Li-Mn battery, NiMH and Li-Ion rechargeable batteries. The 0.6 μ A (TYP) quiescent current maximizes the light load efficiency and also increases the effective battery operation time.

The SGM66099A is able to deliver 300mA output current from 3.3V to 5V conversion, and achieves up to 93% efficiency at 200mA load.

The SGM66099A offers down mode and pass-through mode. In down mode, the desired output voltage is regulated even when the input voltage is higher than the output. In addition, when the input voltage is 270mV above the output voltage set point, the device enters pass-through mode. In pass-through mode, the output voltage follows input voltage.

The device integrates various protection features such as over-current protection, over-voltage protection and thermal shutdown. In addition, the synchronous rectifier supports short-circuit protection which further improves the robustness of the device.

The SGM66099A provides both adjustable output voltage version and fixed output voltage versions. It is available in Green WLCSP-0.85 \times 1.32-6B and TDFN-2 \times 2-6AL packages.

FEATURES

- **Operating Input Voltage Range: 0.7V to 5.5V**
- **Adjustable Output Voltage from 1.8V to 5.5V**
- **2.5V, 3.0V, 3.3V, 3.6V and 5.0V Fixed Output Voltage Versions**
- **Up to 93% Efficiency from 10mA to 300mA Load**
- **Ultra-Low Quiescent Current**
 - ◆ **0.6 μ A (TYP) Ultra-Low I_Q into VOUT Pin**
 - ◆ **0.07 μ A (TYP) Ultra-Low I_Q into VIN Pin**
- **1.2MHz Fixed Frequency Operation**
- **Power-Save Mode for Improved Efficiency at Low Output Power**
- **True Disconnection during Shutdown**
- **Available in Green WLCSP-0.85 \times 1.32-6B and TDFN-2 \times 2-6AL Packages**

APPLICATIONS

- LCD Bias
- Optical Heart Rate Monitor LED Bias
- Portable and Wearable Applications
- Low Power Wireless Applications
- Battery Powered Systems

TYPICAL APPLICATION

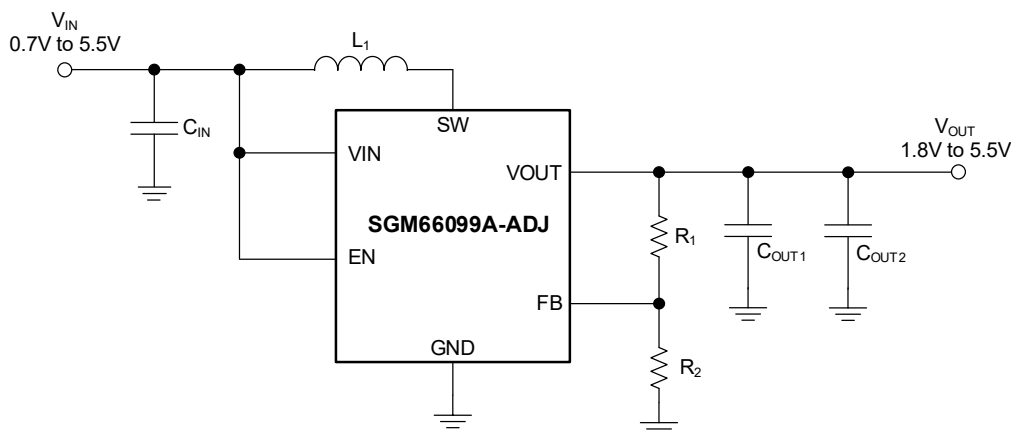

Figure 1. Typical Application Circuit

PACKAGE/ORDERING INFORMATION

MODEL	PACKAGE DESCRIPTION	SPECIFIED TEMPERATURE RANGE	ORDERING NUMBER	PACKAGE MARKING	PACKING OPTION
SGM66099A-2.5	WLCSP-0.85×1.32-6B	-40°C to +125°C	SGM66099A-2.5XG/TR	03 XX	Tape and Reel, 4000
	TDFN-2×2-6AL	-40°C to +125°C	SGM66099A-2.5XTDI6G/TR	0YP XXXX	Tape and Reel, 3000
SGM66099A-3.0	WLCSP-0.85×1.32-6B	-40°C to +125°C	SGM66099A-3.0XG/TR	04 XX	Tape and Reel, 4000
	TDFN-2×2-6AL	-40°C to +125°C	SGM66099A-3.0XTDI6G/TR	0YQ XXXX	Tape and Reel, 3000
SGM66099A-3.3	WLCSP-0.85×1.32-6B	-40°C to +125°C	SGM66099A-3.3XG/TR	05 XX	Tape and Reel, 4000
	TDFN-2×2-6AL	-40°C to +125°C	SGM66099A-3.3XTDI6G/TR	0YR XXXX	Tape and Reel, 3000
SGM66099A-3.6	WLCSP-0.85×1.32-6B	-40°C to +125°C	SGM66099A-3.6XG/TR	06 XX	Tape and Reel, 4000
	TDFN-2×2-6AL	-40°C to +125°C	SGM66099A-3.6XTDI6G/TR	0YS XXXX	Tape and Reel, 3000
SGM66099A-5.0	WLCSP-0.85×1.32-6B	-40°C to +125°C	SGM66099A-5.0XG/TR	02 XX	Tape and Reel, 4000
	TDFN-2×2-6AL	-40°C to +125°C	SGM66099A-5.0XTDI6G/TR	0YT XXXX	Tape and Reel, 3000
SGM66099A-ADJ	WLCSP-0.85×1.32-6B	-40°C to +125°C	SGM66099A-ADJXG/TR	00 XX	Tape and Reel, 4000
	TDFN-2×2-6AL	-40°C to +125°C	SGM66099A-ADJXTDI6G/TR	0YO XXXX	Tape and Reel, 3000

MARKING INFORMATION

NOTE: XX = Date Code. XXXX = Date Code and Trace Code.

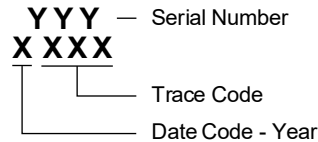
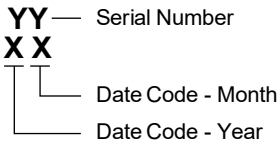

Green (RoHS & HSF): SG Micro Corp defines "Green" to mean Pb-Free (RoHS compatible) and free of halogen substances. If you have additional comments or questions, please contact your SGMICRO representative directly.

Synchronous Boost Converter with Ultra-Low Quiescent Current

SGM66099A

ABSOLUTE MAXIMUM RATINGS

VIN, SW, VOUT, FB, EN to GND.....	-0.3V to 6.0V
Package Thermal Resistance	
WLCSP-0.85×1.32-6B, θ_{JA}	110.6°C/W
WLCSP-0.85×1.32-6B, θ_{JB}	27.4°C/W
WLCSP-0.85×1.32-6B, θ_{JC}	80.5°C/W
TDFN-2×2-6AL, θ_{JA}	59.9°C/W
TDFN-2×2-6AL, θ_{JB}	27.4°C/W
TDFN-2×2-6AL, θ_{JC} (TOP).....	79.2°C/W
TDFN-2×2-6AL, θ_{JC} (BOT).....	9.5°C/W
Junction Temperature.....	+150°C
Storage Temperature.....	-65°C to +150°C
Lead Temperature (Soldering, 10s).....	+260°C
ESD Susceptibility ^{(1) (2)}	
HBM.....	±2000V
CDM.....	±1000V

NOTES:

1. For human body model (HBM), all pins comply with ANSI/ESDA/JEDEC JS-001 specifications.
2. For charged device model (CDM), all pins comply with ANSI/ESDA/JEDEC JS-002 specifications.

RECOMMENDED OPERATING CONDITIONS

Input Voltage Range.....	0.7V to 5.5V
Output Voltage Range.....	1.8V to 5.5V
Operating Junction Temperature Range.....	-40°C to +125°C

OVERSTRESS CAUTION

Stresses beyond those listed in Absolute Maximum Ratings may cause permanent damage to the device. Exposure to absolute maximum rating conditions for extended periods may affect reliability. Functional operation of the device at any conditions beyond those indicated in the Recommended Operating Conditions section is not implied.

ESD SENSITIVITY CAUTION

This integrated circuit can be damaged if ESD protections are not considered carefully. SGMICRO recommends that all integrated circuits be handled with appropriate precautions. Failure to observe proper handling and installation procedures can cause damage. ESD damage can range from subtle performance degradation to complete device failure. Precision integrated circuits may be more susceptible to damage because even small parametric changes could cause the device not to meet the published specifications.

DISCLAIMER

SG Micro Corp reserves the right to make any change in circuit design, or specifications without prior notice.

PIN CONFIGURATIONS

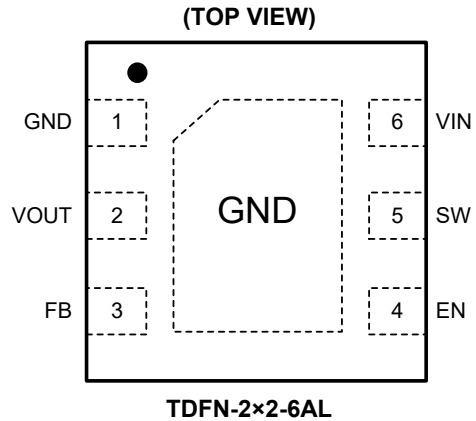
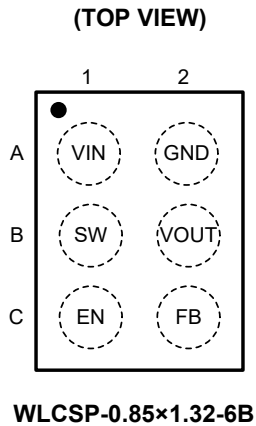

PIN DESCRIPTION

PIN		NAME	TYPE	FUNCTION
WLCSP-0.85×1.32-6B	TDFN-2×2-6AL			
A1	6	VIN	I	Power Supply Input.
A2	1	GND	G	Ground.
B1	5	SW	P	Switch Node. Drain connection of low-side power MOSFET.
B2	2	VOUT	P	Boost Converter Output.
C1	4	EN	I	Device Enable Node. Pulling this pin logic high enables the device, logic low disables the device.
C2	3	FB	I	Voltage Feedback of Adjustable Output Voltage. For adjustable output voltage version, connect a resistive divider to program the desired output voltage. For fixed output voltage version, connect the FB pin to GND or keep floating.
—	Exposed Pad	GND	—	Connect to GND.

NOTE: I = input, O = output, G = ground, P = power for the circuit.

ELECTRICAL CHARACTERISTICS

($T_J = -40^{\circ}\text{C}$ to $+125^{\circ}\text{C}$, $V_{IN} = 0.7\text{V}$ to 5.5V , $C_{IN} = 10\mu\text{F}$, $C_{OUT} = 20\mu\text{F}$, typical values are at $V_{IN} = 3.6\text{V}$, $T_J = +25^{\circ}\text{C}$, unless otherwise noted.)

PARAMETER	SYMBOL	CONDITIONS	MIN	TYP	MAX	UNITS	
Power Supply							
Input Voltage Range	V_{IN}		0.7		5.5	V	
Quiescent Current into VIN Pin	I_Q	No load, not switching, $T_J = -40^{\circ}\text{C}$ to $+85^{\circ}\text{C}$		0.07	0.4	μA	
Quiescent Current into VOUT Pin		No load, not switching, Boost or down mode, $T_J = -40^{\circ}\text{C}$ to $+85^{\circ}\text{C}$		0.6	1.6	μA	
Shutdown Current into VIN Pin	I_{SD}	$EN = \text{GND}$, $V_{IN} = 3.6\text{V}$, $V_{OUT} = 0\text{V}$, $T_J = -40^{\circ}\text{C}$ to $+85^{\circ}\text{C}$		0.1	0.4	μA	
Under-Voltage Lockout Threshold	V_{UVLO}	V_{IN} rising			0.93	V	
		V_{IN} falling	0.19		0.45		
Output							
Output Voltage Range	V_{OUT}		1.8		5.5	V	
Output Voltage		SGM66099A-5.0, $V_{IN} < V_{OUT}$, PWM mode	4.85	5.03	5.21	V	
		SGM66099A-5.0, $V_{IN} < V_{OUT}$, PFM mode		5.101			
		SGM66099A-3.6, $V_{IN} < V_{OUT}$, PWM mode	3.49	3.624	3.76		
		SGM66099A-3.6, $V_{IN} < V_{OUT}$, PFM mode		3.671			
		SGM66099A-3.3, $V_{IN} < V_{OUT}$, PWM mode	3.19	3.324	3.46		
		SGM66099A-3.3, $V_{IN} < V_{OUT}$, PFM mode		3.367			
		SGM66099A-3.0, $V_{IN} < V_{OUT}$, PWM mode	2.88	3.022	3.16		
		SGM66099A-3.0, $V_{IN} < V_{OUT}$, PFM mode		3.063			
		SGM66099A-2.5, $V_{IN} < V_{OUT}$, PWM mode	2.41	2.52	2.63		
		SGM66099A-2.5, $V_{IN} < V_{OUT}$, PFM mode		2.555			
Feedback Reference Voltage	V_{REF}	$V_{IN} < V_{OUT}$, PWM mode	0.94	1.007	1.07	V	
		$V_{IN} < V_{OUT}$, PFM mode		1.021			
Output Over-Voltage Protection Threshold	V_{OVP}	SGM66099A-ADJ		5.8		V	
		SGM66099A-5.0		5.3			
		SGM66099A-2.5, SGM66099A-3.0, SGM66099A-3.3, SGM66099A-3.6		$1.1 \times V_{OUT}$			
OVP Hysteresis-ADJ			100		mV		
Leakage Current into FB Pin	I_{FB_LKG}	$V_{FB} = 1.1\text{V}$			100	nA	
Switching							
Switching Frequency	f_{SW}		0.8	1.2	1.5	MHz	
Power Switch							
Low-side Switch On-Resistance	R_{DSON_LS}	$V_{OUT} = 5.0\text{V}$	TDFN-2x2-6AL		176	341	m Ω
			WLCSP-0.85x1.32-6B		163	320	
		$V_{OUT} = 3.3\text{V}$	TDFN-2x2-6AL		221	426	
			WLCSP-0.85x1.32-6B		208	400	
		$V_{OUT} = 1.8\text{V}$	TDFN-2x2-6AL		398	652	
			WLCSP-0.85x1.32-6B		385	635	
Rectifier On-Resistance	R_{DSON_HS}	$V_{OUT} = 5.0\text{V}$	TDFN-2x2-6AL		173	290	m Ω
			WLCSP-0.85x1.32-6B		157	270	
		$V_{OUT} = 3.3\text{V}$	TDFN-2x2-6AL		217	400	
			WLCSP-0.85x1.32-6B		200	350	
		$V_{OUT} = 1.8\text{V}$	TDFN-2x2-6AL		363	550	
			WLCSP-0.85x1.32-6B		348	540	

ELECTRICAL CHARACTERISTICS (continued)

($T_J = -40^\circ\text{C}$ to $+125^\circ\text{C}$, $V_{IN} = 0.7\text{V}$ to 5.5V , $C_{IN} = 10\mu\text{F}$, $C_{OUT} = 20\mu\text{F}$, typical values are at $V_{IN} = 3.6\text{V}$, $T_J = +25^\circ\text{C}$, unless otherwise noted.)

PARAMETER	SYMBOL	CONDITIONS	MIN	TYP	MAX	UNITS
Current Limit Threshold	I_{LIM}	SGM66099A-ADJ, $V_{OUT} \geq 2.5\text{V}$, Boost	0.75	1	1.52	A
		SGM66099A-Fixed, Boost	0.75	1	1.20	
Control Logic						
EN Input Low Voltage Threshold	V_{IL}	$V_{IN} \leq 1.5\text{V}$			$0.2 \times V_{IN}$	V
		$V_{IN} > 1.5\text{V}$			0.3	
EN Input High Voltage Threshold	V_{IH}	$V_{IN} \leq 1.5\text{V}$	$0.8 \times V_{IN}$			V
		$V_{IN} > 1.5\text{V}$	1.2			
Leakage Current into EN Pin	I_{EN_LKG}	$V_{EN} = 5.0\text{V}$			200	nA
Over-Temperature Protection				145		$^\circ\text{C}$
Over-Temperature Hysteresis				25		$^\circ\text{C}$

TYPICAL PERFORMANCE CHARACTERISTICS

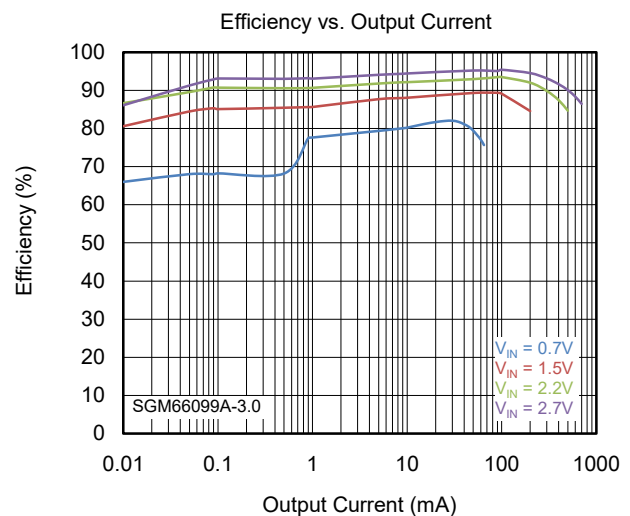
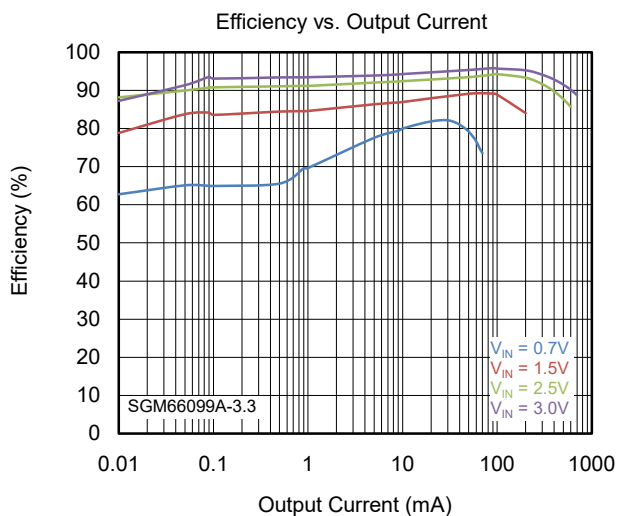
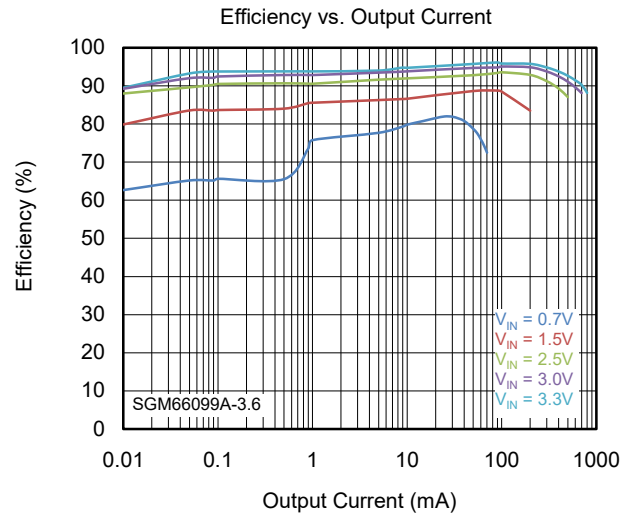
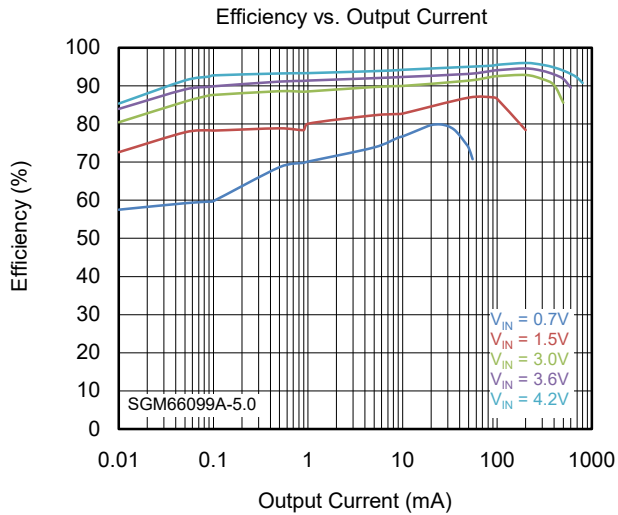
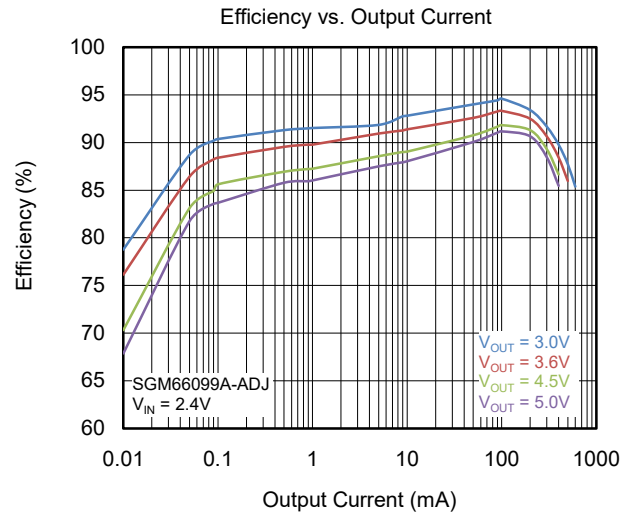
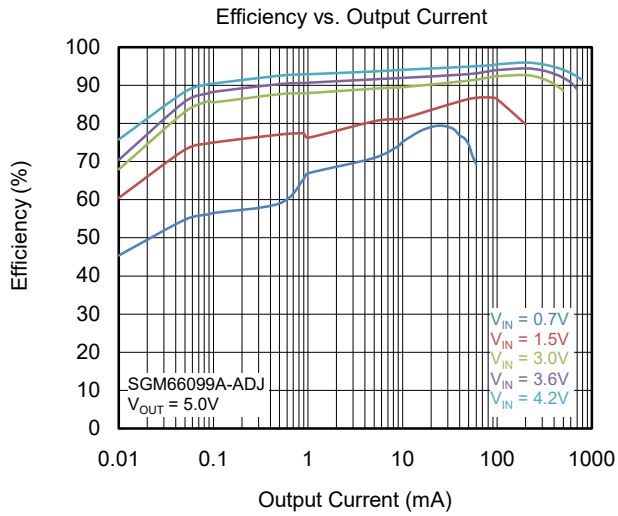

TYPICAL PERFORMANCE CHARACTERISTICS (continued)

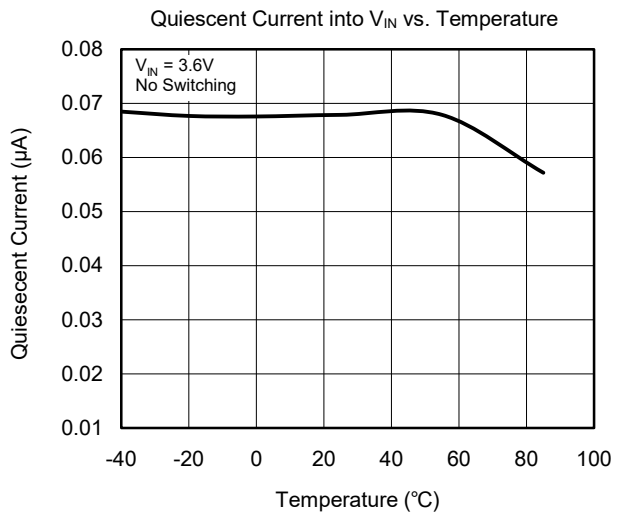
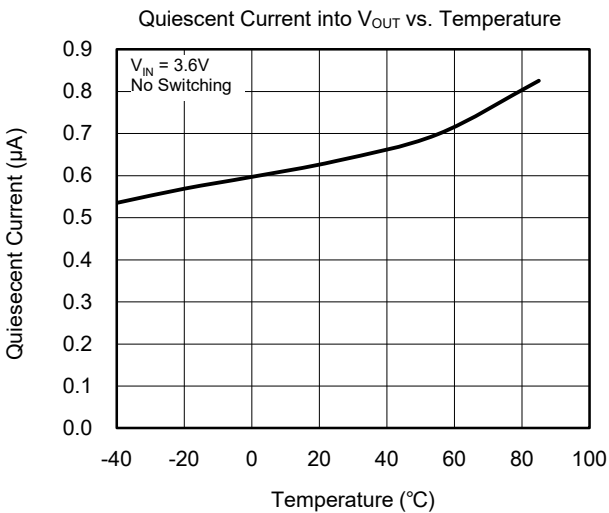
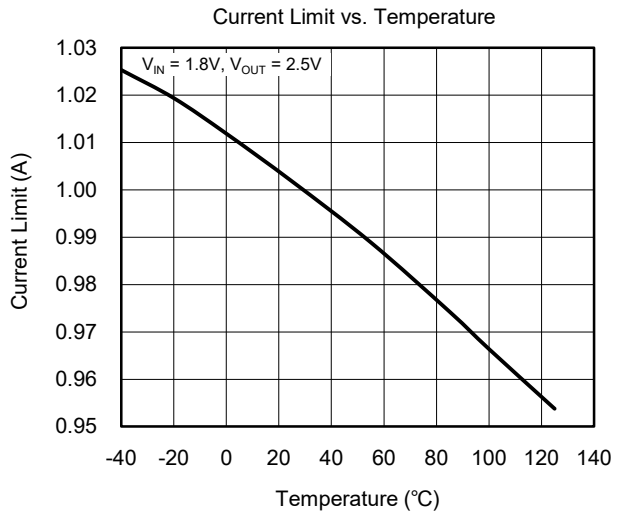
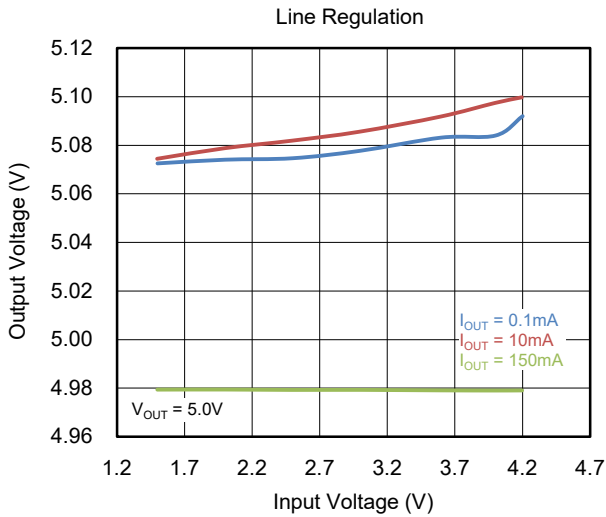
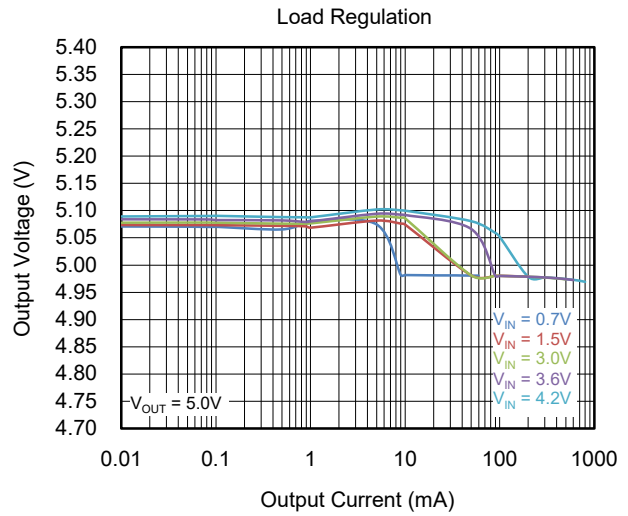
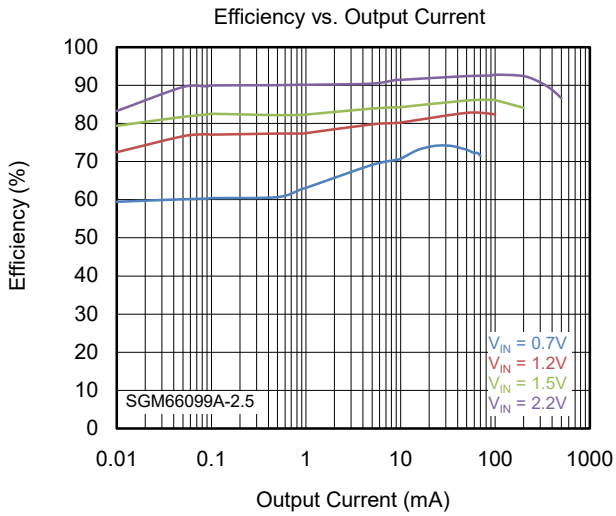

TYPICAL PERFORMANCE CHARACTERISTICS (continued)

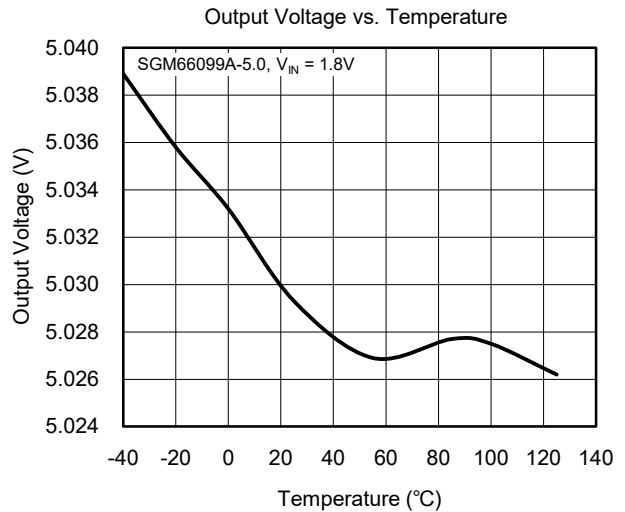
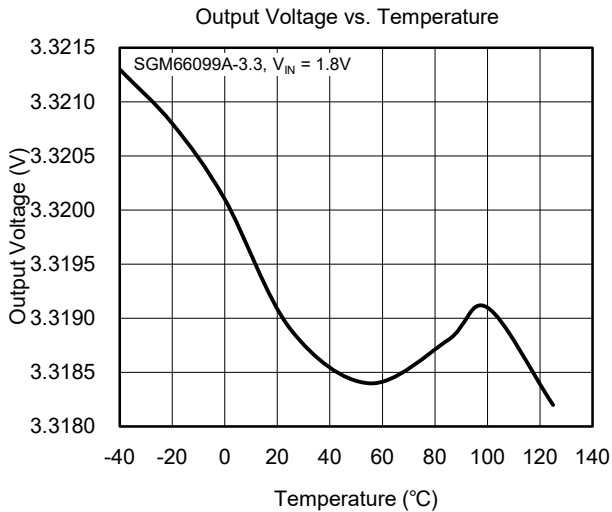
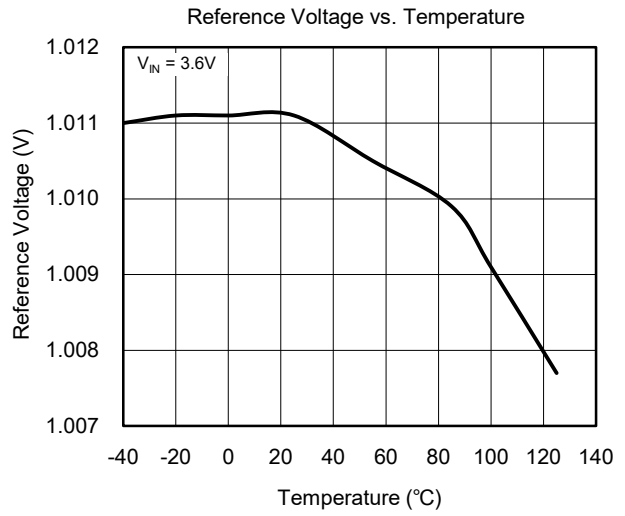
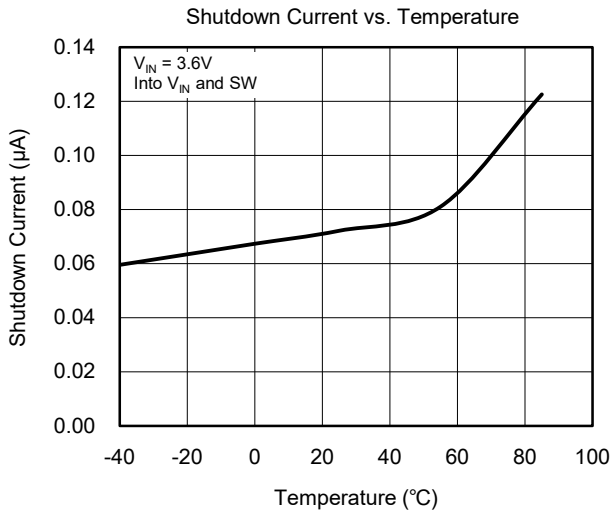

TYPICAL PERFORMANCE CHARACTERISTICS (continued)

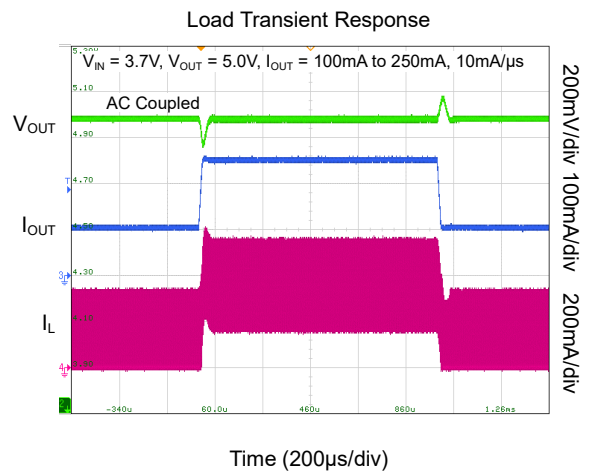
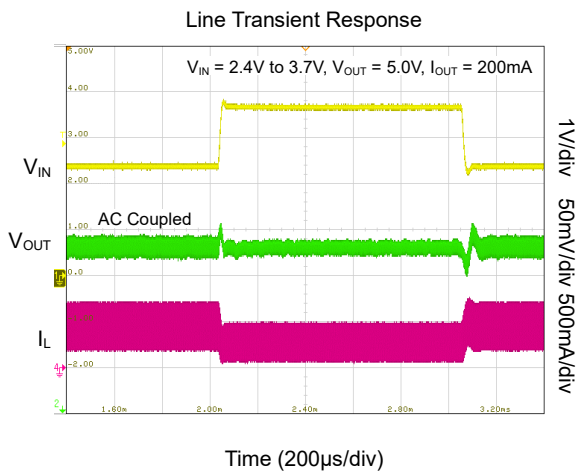
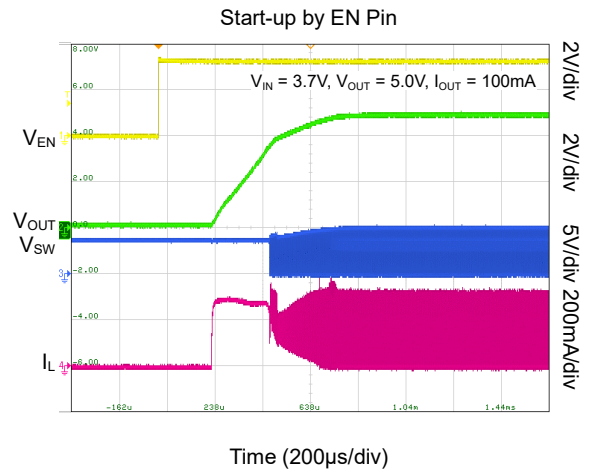
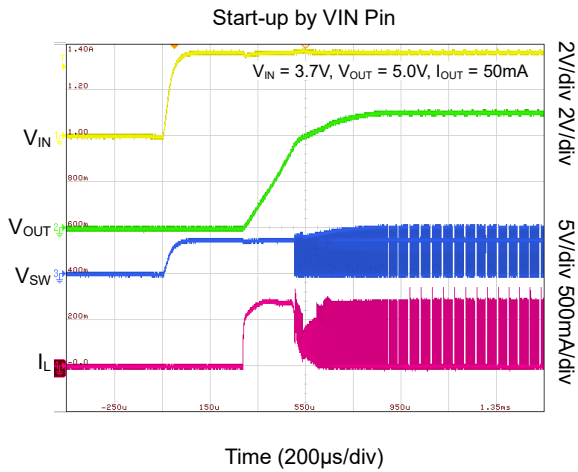
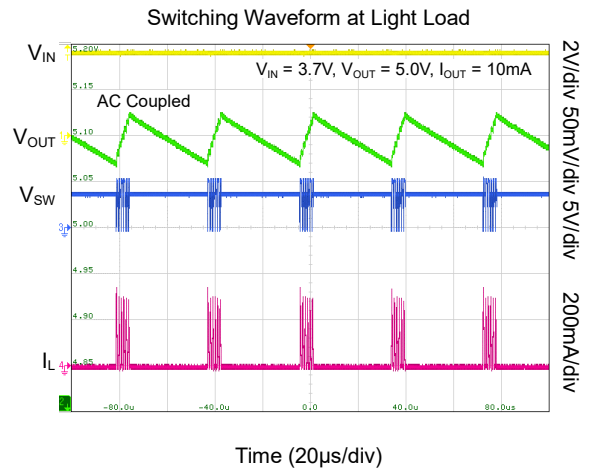
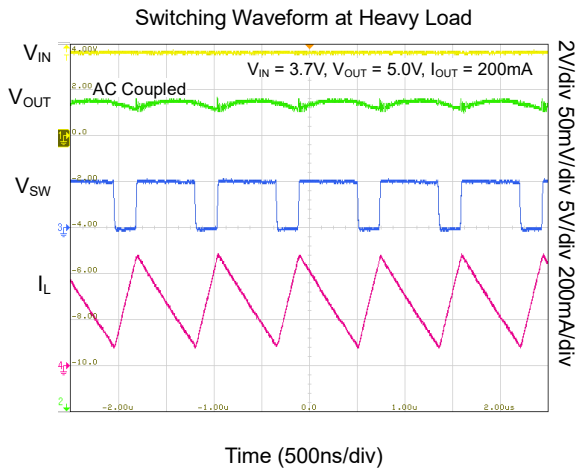

TYPICAL PERFORMANCE CHARACTERISTICS (continued)

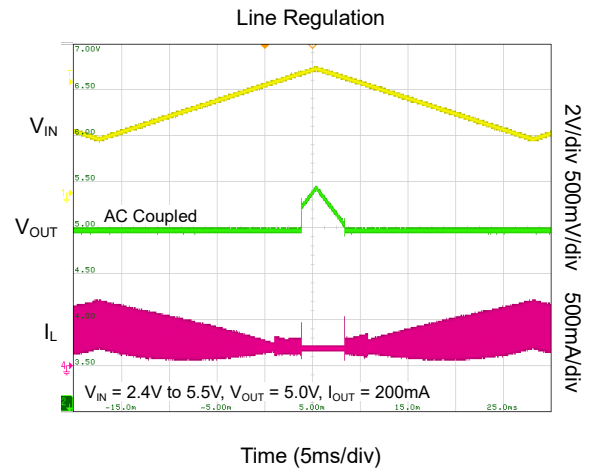
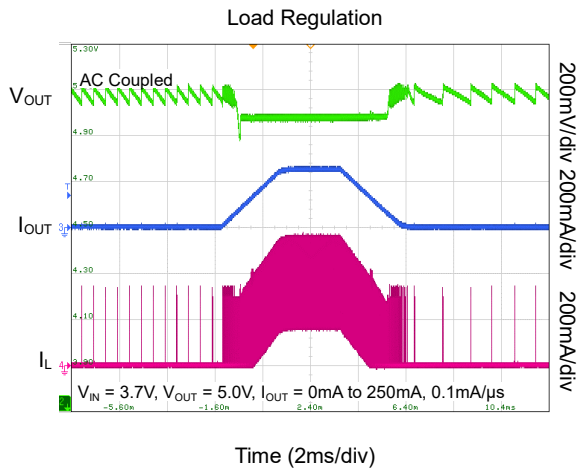

FUNCTIONAL BLOCK DIAGRAM

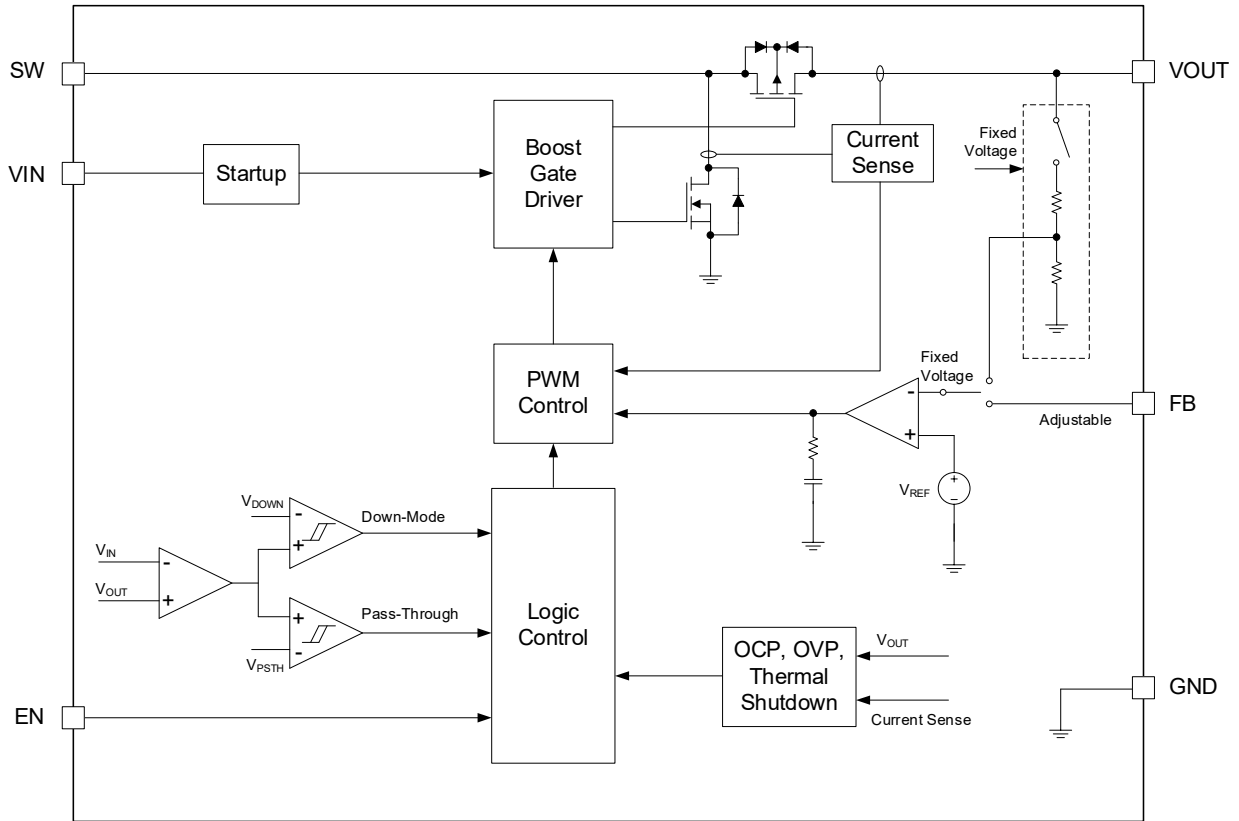

Figure 2. Block Diagram

DETAILED DESCRIPTION

The SGM66099A synchronous Boost converter is designed for Li-Ion battery powered systems, where the compact solution size and battery operation time are key criterions. The device can operate with a wide input voltage from 0.7V to 5.5V. The 0.6 μ A (TYP) quiescent current and light load power-save mode further improve the system efficiency. The device employs peak current mode control with 1A (TYP) peak switch current limit. The SGM66099A is capable of disconnecting the output from input when the device is disabled to avoid unnecessary current consumption. The down mode and pass-through mode ensure a smooth operation when input voltage is close to or higher than the set output voltage. The device can operate both in the adjustable output voltage version and fixed output voltage version.

Startup and Enable

Logic high on EN pin enables the SGM66099A, while logic low disables the device. During logic low state, the device stops operation, and the output voltage is completely disconnected from the input voltage. During logic low state, the shutdown current is less than 0.4 μ A.

The SGM66099A is able to start up from 0.8V (TYP) input voltage with larger than 3k Ω load. During the initial startup phase, the output voltage reaches the input voltage through the high-side PMOS with 300mA (TYP) pre-charge current. After the pre-charge phase, the output voltage will be charged to 1.77V in the free-running mode when V_{OUT} is lower than 1.77V. The duty cycle remains fixed at 80% in the free-running mode with the constant switching frequency of 750kHz and a peak current limit of about 300mA. Once the output voltage is higher than 1.77V, the device will transition into the closed-loop control mode. In this mode, the FB voltage follows the soft-start voltage and the current limit is increased to 560mA (TYP) for the down mode and 1A (TYP) for the Boost mode.

Over-Current and Short-Circuit Protection

The SGM66099A implements cycle-by-cycle current limit during an over-current event. When the current limit threshold (I_{LIM}) is reached, the control loop can limit the inductor current to prevent the inductor current from further increasing. During over-current event, the output voltage will drop until a constant power state is reached between input and output. When V_{OUT} is lower than 2.3V, the device will transition into the foldback current limit mode and the current limit will be decreased to about 750mA. If the output voltage is close to the input voltage, the device will transition into the down mode with a 560mA (TYP) peak current limit.

Once the output voltage drops below 1.65V (TYP), the device will try to start up again.

During the output short-to-ground case, as output voltage declines below 0.7V, the SGM66099A transitions into the pass-through mode and reduces the current limit to about 300mA to reduce power dissipation within the device. As the short-circuit condition is removed, the device resumes operation and goes through a soft-start sequence to regulate the set output voltage.

Over-Voltage Protection

SGM66099A integrates over-voltage protection (OVP) to protect the device in the event of feedback resistor short-to-ground or incorrect feedback resistor value being populated. The SGM66099A stops switching when the OVP threshold of 5.8V (adjustable version) or 5.3V (fixed output voltage versions) is reached. The device implements 100mV OVP hysteresis. When the output voltage is 100mV lower than the OVP threshold, the device resumes switching. If FB pin is continuously shorted to GND, the OVP threshold of adjustable output voltage version decreases from 5.8V to 5.3V. In addition, the FB pin voltage is monitored by SGM66099A. Switching is terminated when $V_{FB} > 1.1 \times V_{REF}$, and normal switching is resumed when FB pin voltage drops back to $1.07 \times V_{REF}$.

Power-Save Mode under Light Load Condition

The SGM66099A enters into power-save mode under light load condition.

Down Mode and Pass-Through Mode

The SGM66099A features down mode and pass-through mode when the input voltage is higher than output voltage.

In down mode, the device can still hold the target output voltage even though the input voltage exceeds the output voltage. The V_{GS} of high-side PMOS is dynamically adjusted to provide a down slope to the inductor current. This method allows effective control of inductor current and achieves less power dissipation.

In pass-through mode, the switching action stops. The gate of high-side PMOS is pulled to ground for always-on and the low-side switch remains off. In this mode, the output voltage is equivalent to the input voltage reduced by the voltage drop that occurs across the DC resistance (DCR) of the inductor as well as the on-resistance of the high-side PMOS.

DETAILED DESCRIPTION (continued)

As the input voltage increasingly ramps up, the SGM66099A transitions into the down mode first when the input voltage is 80mV (TYP) lower than the output voltage. The device remains in the down mode until the input voltage exceeds the output voltage by 270mV (TYP). After that, the SGM66099A will automatically transition into the pass-through mode. In the pass-through mode, the output voltage follows the input voltage. When the input voltage decreases to 101% (TYP) of the target output voltage, the SGM66099A exits the pass-through mode and transitions back to the down mode. The device remains in the down mode until the input voltage drops to 150mV (TYP) below the output voltage, at which point it will resume the Boost mode.

Thermal Shutdown

A thermal shutdown function is implemented to prevent damage caused by excessive heat and power dissipation. Once a temperature of typically +145°C is exceeded, the device is shut down. The device is released from shutdown automatically when the junction temperature drops to 25°C.

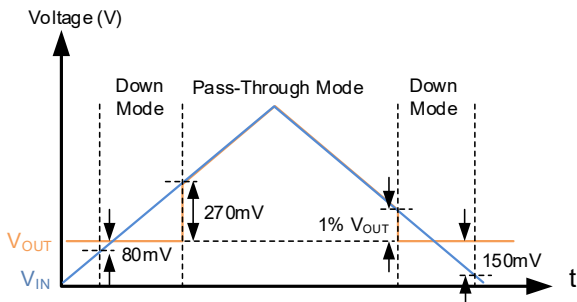

Figure 3. Down Mode and Pass-Through Operation

APPLICATION INFORMATION

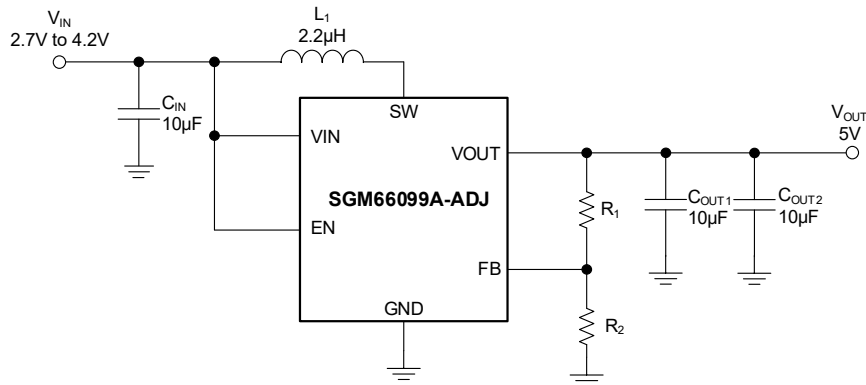

Figure 4. 5V Output Boost Converter

Design Requirements

5V output at 1mA load current is used to provide system bias power or LED bias voltage from a single cell Li-Ion battery as an example. The selection of external component values for the SGM66099A-ADJ can reference the following design procedure.

Table 1. Design Requirements

PARAMETERS	VALUES
Input Voltage	2.7V ~ 4.2V
Output Voltage	5V
Output Current	1mA
Output Voltage Ripple	±50mV

Programming the Output Voltage

External resistor dividers R₁ and R₂ (see Figure 4) can be used to program the output voltage. V_{REF} is 1.0V (TYP).

$$V_{OUT} = V_{REF} \times \frac{R_1 + R_2}{R_2} \tag{1}$$

The leakage current into the FB pin affects the accuracy of output voltage. To achieve the minimum leakage current effect, the current flowing through R₂ should be 100 times greater than FB pin leakage current. Small R₂ increases the noise immunity, while

large R₂ reduces the leakage current flowing through feedback resistors, which improves the no load efficiency of the device. A 1MΩ resistor is chosen for R₁ and a 249kΩ resistor is chosen for R₂ in this case. ±1% accuracy resistors are recommended for R₁ and R₂ to improve output voltage accuracy.

For fixed output voltage version, connect the FB pin to GND or keep floating.

Maximum Output Current

The maximum output load capability of SGM66099A depends on the minimum desired operation input voltage and the current limit of the device. Equation 2 can be used to calculate the maximum load current.

$$I_{OUT(MAX)} = \frac{V_{IN} \cdot (I_{LIM} - \frac{I_{LH}}{2}) \cdot \eta}{V_{OUT}} \tag{2}$$

where η is the conversion efficiency, using 85% for estimation. I_{LH} is the current ripple value and I_{LIM} is the switch current limit.

For worst-case condition analysis, the minimum input voltage, maximum Boost output voltage and minimum current limit (I_{LIM}) should be used.

APPLICATION INFORMATION (continued)

Inductor Selection

Inductor selection is one of the most important criterions for switch mode power supply, because the inductor selection may affect the power supply’s transient response, loop stability, efficiency and steady-state operation. Inductor parameters of DC resistance (DCR), inductance and saturation current are critical for a smooth and efficient power supply operation.

The internal compensation of the device is optimized with 1µH and 2.2µH. When V_{OUT} is higher than 3V, 2.2µH inductance should be selected. When V_{OUT} is less than 3V, 1µH inductance should be selected.

Capacitor Selection

The input capacitor of Boost converter not only minimizes input voltage ripple, but also reduces any voltage spike presenting on IC’s VIN pin. A 10µF, low ESR and X5R or higher temperature coefficient ceramic capacitor is recommended to place as close to the VIN and GND pins as possible to improve transient response and EMI behavior.

Boost converter’s output capacitor plays a significant role in ensuring good system performance. The location of output capacitor will have an effect on the switching spikes on the SW pin, which ultimately affects EMI performance and potentially damages the IC due to large switching spikes. The current loop formed by the output capacitor flowing from the VOUT pin and back to the GND pin should be as small as possible. Therefore, a ceramic cap is recommended to put as close to the VOUT and GND pins of the device as possible.

Boost topology presents right-half-plane-zero which is dictated by inductance. In addition, the output capacitor sets the corner frequency of the converter for current mode controlled method. Therefore, when selects a larger inductor, there should be a larger output capacitor. The device’s internal compensation is optimized to operate with inductance values between 1µH and 2.2µH, resulting in the minimum output capacitor value of 20µF (nominal value). Increasing the output capacitor can reduce output ripple in PWM mode.

Due to the nature of ceramic capacitors’ DC bias effect, effective capacitance at the bias voltage should be verified. GRM188R61E106MA73D is used for V_{OUT} rail. It is a 10µF ceramic capacitor and has high effective capacitance value at DC biased condition.

In the case of load hot-plugging, the input capacitance of load device needs to be less than 1/10 of the output capacitance of SGM66099A.

Layout

In addition to component selection, layout is a critical step to ensure the performance of any switch mode power supplies. Poor layout could result in system instability, EMI failure, and device damage. Thus, place the inductor, input and output capacitors as close to the IC as possible, and use wide and short traces for current carrying traces to minimize PCB inductance.

For Boost converter, the current loop of the output capacitor from VOUT pin back to the GND pin of the device should be as small as possible.

Table 2. List of Inductors

V _{OUT} (V)	Inductance (µH)	Saturation Current (A)	DC Resistance (mΩ)	Size (L × W × H)	Part Number	Manufacturer
≥ 3.0	2.2	6.5	51	4.06 × 4.06 × 1.8	74437324022	Würth Elektronik
	2.2	1.95	80	2.5 × 2.0 × 1.2	74404024022	Würth Elektronik
	2.2	1.95	80	2.5 × 2.0 × 1.2	SPH252012H2R2M	Sunlord
< 3.0	1.0	6.5	22	4.06 × 4.06 × 1.8	74437324010	Würth Elektronik
	1.0	2.6	37	2.5 × 2.0 × 1.2	74404024010	Würth Elektronik
	1.0	2.45	67	2.5 × 2.0 × 1.0	SPH252010H1R0MT	Sunlord

REVISION HISTORY

NOTE: Page numbers for previous revisions may differ from page numbers in the current version.

MARCH 2025 – REV.A.1 to REV.A.2	Page
Updated the Pin Description	4

FEBRUARY 2025 – REV.A to REV.A.1	Page
Updated the Electrical Characteristics	5

Changes from Original (DECEMBER 2024) to REV.A	Page
Changed from product preview to production data.....	All

PACKAGE INFORMATION

PACKAGE OUTLINE DIMENSIONS

WLCSP-0.85×1.32-6B

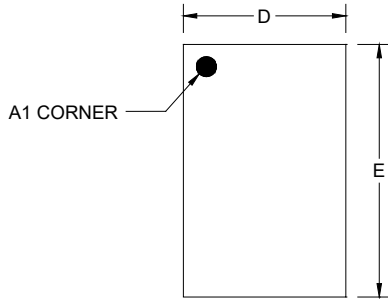

TOP VIEW

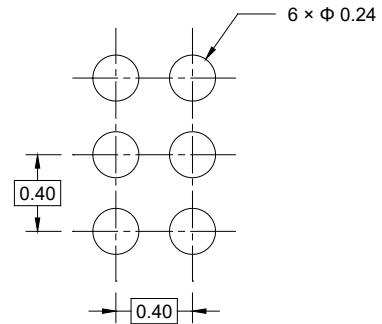

RECOMMENDED LAND PATTERN (Unit: mm)

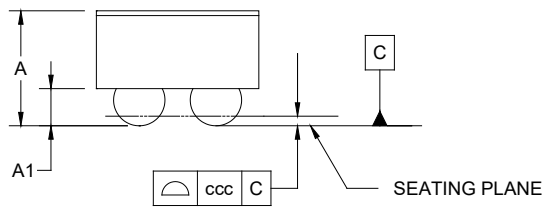

SIDE VIEW

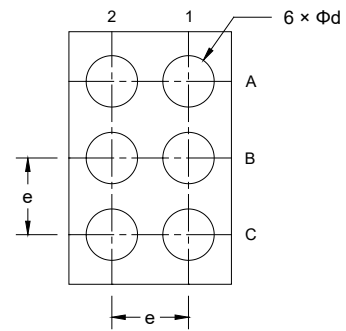

BOTTOM VIEW

Symbol	Dimensions In Millimeters		
	MIN	NOM	MAX
A	-	-	0.645
A1	0.174	-	0.214
D	0.818	-	0.878
E	1.288	-	1.348
d	0.238	-	0.298
e	0.400 BSC		
ccc	0.050		

NOTE: This drawing is subject to change without notice.

PACKAGE OUTLINE DIMENSIONS

TDFN-2x2-6AL

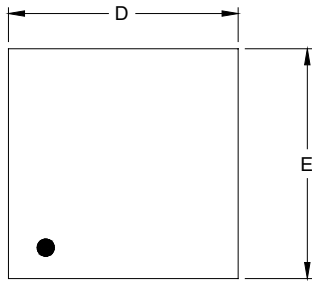

TOP VIEW

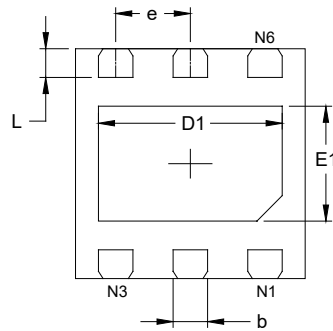

BOTTOM VIEW

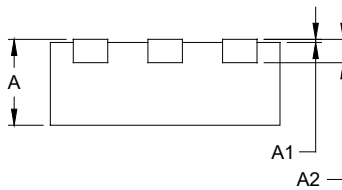

SIDE VIEW

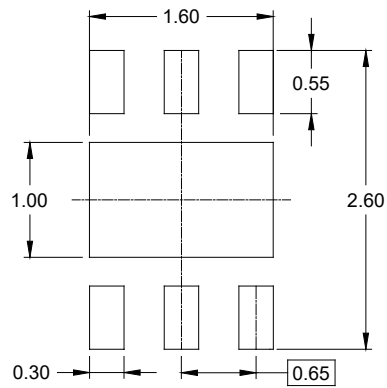

RECOMMENDED LAND PATTERN (Unit: mm)

Symbol	Dimensions In Millimeters		Dimensions In Inches	
	MIN	MAX	MIN	MAX
A	0.700	0.800	0.028	0.031
A1	0.000	0.050	0.000	0.002
A2	0.203 REF		0.008 REF	
D	1.900	2.100	0.075	0.083
D1	1.500	1.700	0.059	0.067
E	1.900	2.100	0.075	0.083
E1	0.900	1.100	0.035	0.043
b	0.250	0.350	0.010	0.014
e	0.650 BSC		0.026 BSC	
L	0.174	0.326	0.007	0.013

NOTE: This drawing is subject to change without notice.

TAPE AND REEL INFORMATION

REEL DIMENSIONS

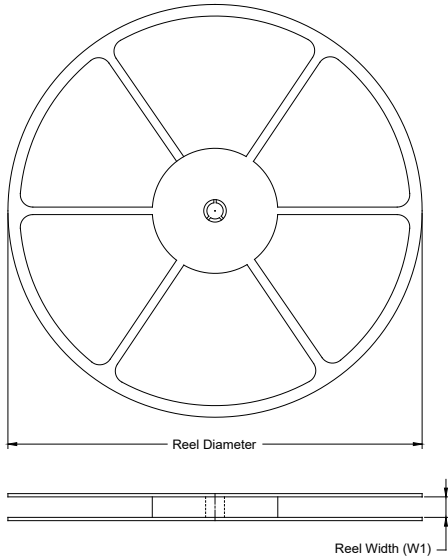

TAPE DIMENSIONS

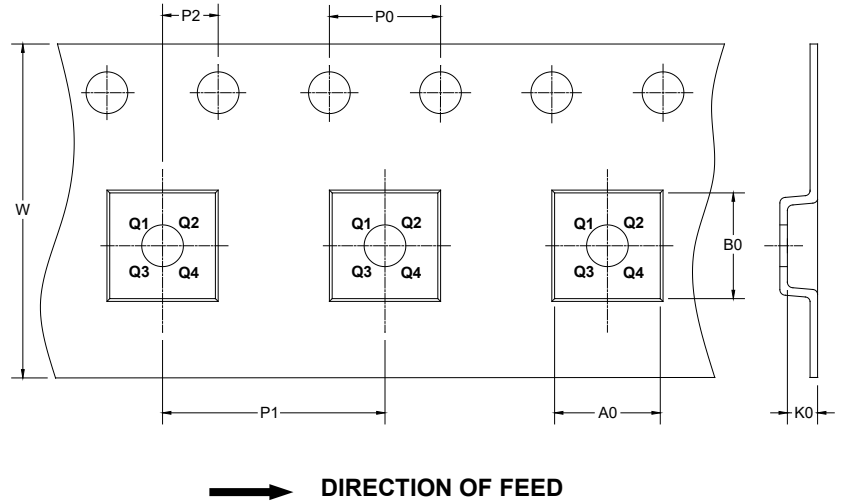

NOTE: The picture is only for reference. Please make the object as the standard.

KEY PARAMETER LIST OF TAPE AND REEL

Package Type	Reel Diameter	Reel Width W1 (mm)	A0 (mm)	B0 (mm)	K0 (mm)	P0 (mm)	P1 (mm)	P2 (mm)	W (mm)	Pin1 Quadrant
WLCSP-0.85×1.32-6B	7"	9.5	0.95	1.45	0.71	4.0	4.0	2.0	8.0	Q1
TDFN-2×2-6AL	7"	9.5	2.30	2.30	1.10	4.0	4.0	2.0	8.0	Q2

DD0001

PACKAGE INFORMATION

CARTON BOX DIMENSIONS

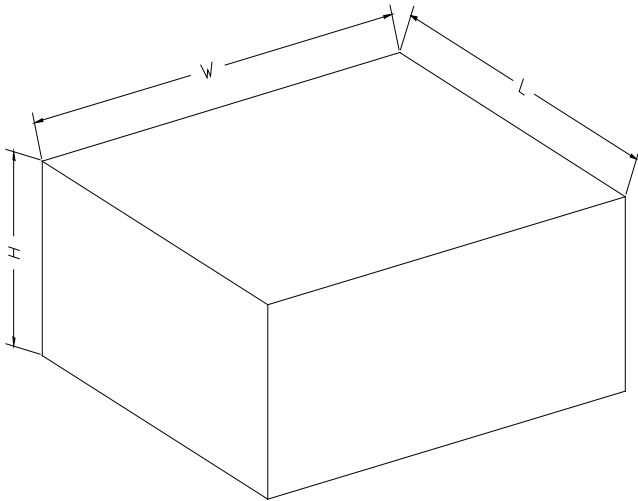

NOTE: The picture is only for reference. Please make the object as the standard.

KEY PARAMETER LIST OF CARTON BOX

Reel Type	Length (mm)	Width (mm)	Height (mm)	Pizza/Carton
7" (Option)	368	227	224	8
7"	442	410	224	18

D00002